



Become a MATADOR.

€ Preis-Katalog
Price-Catalogue

M100

Qualitätshandwerkzeuge und mehr seit 1900.
High quality hand tools and more since 1900.

Liebe Freunde von MATADOR,

endlich liegt er vor Ihnen, unser neuer Katalog. Druckfrisch und vollgepackt mit Qualitätshandwerkzeugen von MATADOR.

Wir haben unser Programm komplett überarbeitet und über 300 neue Artikel aufgenommen.

Unser Ziel ist es, Ihnen ein umfassendes Angebot an Standard-Handwerkzeugen in hoher Qualität zu bieten. Als Hersteller mit über 100 Jahren Fertigungs-Know How wissen wir, wo Qualität entsteht und wie wir sie weiterentwickeln können. Nach wie vor verfügen wir am Standort Remscheid in Deutschland über die gesamte Wertschöpfungskette zur Herstellung von Werkzeugen: Eine eigene Schmiede mit bis zu 500t Schmiedekapazität, zahlreiche Maschinen zur Oberflächenbearbeitung, eine vollautomatische Härteanlage und eine hochmoderne Galvanik zum Verchromen unserer Werkzeuge (natürlich Chrom VI-frei). Die eigene Fertigung garantiert eine hohe Flexibilität und gleichbleibende Qualität - Made in Germany.

Neben zahlreichen Neuheiten an einzelnen Werkzeugen ist besonders unser ModuFlex-System für Werkstattwagen hervorzuheben. Damit geben wir Ihnen mehr denn je die Möglichkeit, sich Ihren individuellen Werkstattwagen zusammenzustellen.

Ebenfalls stark erweitert haben wir unseren Spezialwerkzeugbereich. Geholfen bei der Auswahl der wirklich wichtigen Werkzeuge haben uns vor allem unsere langjährigen Beziehungen zur Automobilindustrie.

Und noch eine Neuheit: Achten Sie auf alle "roten Preise". Dies sind Rennerartikel, die wir extrem scharf kalkuliert haben und mit denen wir uns dem zunehmenden Wettbewerb stellen möchten - natürlich in MATADOR-Qualität.

Wenn Sie Kritik und Verbesserungsvorschläge rund um Werkzeug haben, kontaktieren Sie uns. Ihre Meinung ist uns sehr wichtig.

Herzlichst

Ihr Peter Kissling

Dear friends of MATADOR!

We can finally present it to you - our brand new catalogue full of MATADOR quality tools.

We completely revised our product range and added more than 300 new items.

Our goal is to offer a wide range of top-quality standard hand tools. With more than 100 years of experience and know how we really know where quality originates and how to advance it. At our production site in Remscheid, Germany, we still hold the whole value chain for tool production: our own forging department with a forging capacity of up to 500 tons, several machines for surface treatment, a fully automatic hardening plant and an ultra-modern galvanic plant for chrome-plating (chrome VI-free, of course). This guarantees a high level of flexibility as well as the constant first-class quality of our tools - Made in Germany.

Besides numerous novelties in our standard tool range we would especially like to draw your attention to our ModuFlex system for workshop trolleys. This innovative system offers you more than ever the possibility to compile your individual workshop trolley.

We also extensively expanded our range of special tools. Our long standing business relationship with the automotive industry helped us to make the best choice out of the most important tools.

And this is also new: Please pay attention to our "red prices". They highlight our fast moving items which we sell at our best price - of course in the well-known MATADOR quality.

Whenever you may have any questions, concerns or suggestions for improvement, please do not hesitate to contact us. We attach great importance to your opinion.

With best wishes

Peter Kissling



Peter Kissling
Geschäftsführender Gesellschafter
Managing Partner

T: +49 (0) 21 91 - 97 43 - 43

F: +49 (0) 21 91 - 97 43 - 46

E: kissling@matador.de



Neuheiten / News

A

5-Stern-Schraubendreher / 5-Star Screwdrivers T-Handle
Ausbeulwerkzeug-Sätze / Body and Fender Tool Set
Ausglaswerkzeug-Satz / Windscreen Removal Kit
Auspuff-Klemmfederspanner / Spring Spanner for exhaust systems
Axial Grip Pliers / Axial Grip Pliers

B

Batterietester / Batteryx Cell Tester
Bremsenentlüftungsschlüsse / Brake Bleeding Wrenches

D

Diamant-Schraubendreher-Satz / Set of Diamond Grip-Screwdrivers
Dichtungs- und Glasschaber / Scraper for Gasket and Glass
Digitaler Drehmomentschlüsse / Digital Torque Wrenches
Digitaler Meßschieber / Electronic Caliper
Drehmoment-Einsteckwerkzeuge / Insert Tools für Torque Wrenches
Drehmomentschlüssel Eco Line / Torque Wrenches EcoLine
Drehmomentschlüssel zur Festeinstellung / Preset Torque Wrenches
Drehmoment-Schraubendreher / Torque Screwdrivers
Drehmoment-Vervielfältiger / Torque Multiplier
Düseneinsteller Waschanlage / Nozzle Adjusting Tool

E

Einsteck-Drehmomentschlüssel / Torque Wrenches , for insert tools
Elektroniker Zangen / Electronic Nose Plier
Elektroniker-Satz 44-tlg. / Set for electronics , 44-pcs.
Elektroniker-Schraubendreher / Electronic Screwdrivers
Elektronischer Drehmomententester, stationär / Torque Tester
Entriegelungssätze / Set of Extraction Tools

F

Flachsteckwerkzeuge / Flat Terminal Extractors

G

Gabelsteckwerkzeuge / Fork Terminal Extractors
Gewindereparaturätze / Thread Repair Sets
Glühkerzen-Einsätze 3/8., / Glow Plug Sockets 3/8"
Glühkerzen-Ratschenschlüssel / Ratchet Wrench for Glow Plugs

H

Hämmer mit Fiberglasstiel / Hammer with Fibreglass Shaft
Handhebelpresse TWIN-LOCK / Lever Grease Gun TWIN LOCK
Hebelblechscheren / Lever Tin Snips
Hebeleisen-Satz / Set of Pry Bars

I

Impact-Schraubenausdreher-Satz / Twist Socket Set

K

Ketten-Rohrabschneider / Chain Pipe Cutter
Klauen-/Zapfenschlüssel / Claw Wrenches
Knarre 1/2", verlängerbare / Reversible Ratchet 1/2", Extended
Knarre 1/4", flexibel / Reversible Ratchet 1/4", flexible
Knarre-umschalbar 3/4", feinverzahnt / Reversible Ratchet 3/4"
Kraft-Einsätze 1/2", TORX / Impact Socket 1/2", TORX
Kraft-Einsätze 1/4" / Impact Socket 1/4"
Kraft-Einsätze 3/4", B&S-XZN / Impact Socket 3/4", B&S-XZN
Kraft-Einsätze 3/4", extra lang / Impact Socket 3/4", long type
Kraft-Einsätze 3/4", Innensechsk. / Impact Socket 3/4", inside hexagon
Kraft-Einsätze 3/4", TORX / Impact Socket 3/4", TORX
Kraft-Einsätze 3/8" / Impact Socket 3/8"
Kraft-Kombinationszange / Heavy Duty Combination Pliers
Kraft-LKW-Satz / Impact Socket-Set
Kugelgelenkausdrücker / Ball Joint Pullers

L

Lambdasonden-Einsätze / Qxygen / Lambda Sockets
Leckölzange für Rückklaufeitungen / Leak Off Pliers

M

Magnetheber mit Beleuchtung / Magnetic Pick Up Tools with lamp
Mechanische Winkelscheiben / Mechanical Angle Dials
Mini-Doppemaulschlüssel / Double Open Ended Midget Spanners
ModulFlex - System / ModulFlex - System
Motorsteuerung- Sonderwerkzeuge / Engine Timing Tools
Mutternsprenger, hydraulisch / Hydraulic Nut Splitters

O

Ölfilter-Einsätze / Schlüssel / Oil Filter Sockets / Wrenches

P

Präzisions-Innenauszieher / Internal Pullers
Professionelles Fiberglas-Endoskop / Fibreglas Endoscope

R

Radmutterchl. verlängerbare / Extendable Wheel Nut Wrench
Ratschenringschlüssel / Double Box Wrenches
Refraktometer / Refractometer
Reifenprofil-Tiefenmesser / Brass Tyre Profile Depth Gauge
Riemenscheiben-Abzieher / V-Belt Pulley Puller Set
Riemenscheiben-Schlüssel / Belt Pulley Back-Up Wrenches
Rundsteckwerkzeuge / Circular Terminal Extractors

S

Scheibenwischerarm-Abzieher / Windscreen Wiper Arm Pulling Set
Schlauchklemmenzange / Hose Clamp Pliers
Schneid- und Bördelsatz / Tubing Cutter and Flaring Tool Set
Schraubendreher, extra lange / Screwdrivers, long type
Schraubendreher-Bits / Screwdrivers Bits
Schraubendr.-Einsätze 3/8", RIBE / Screwdriver Socket 3/8", RIBE
Seitenschneider / Side Cutting Nippers
Sicherheitsmesser / Safety Cutter
Spezial-Glühkerzenauszieher / Special Glow Plug Tool
Steckschlüssel-Einsätze 1/4", 5-Stern / Sockets 1/4", 5-star
Steckschlüssel-Einsätze 3/8", lang / Hexagon Sockets, long type
Steckschlüssel-Garnituren 1/2, / Socket Set 1/2"
Steckschlüssel-Garnituren 3/8, / Socket Set 3/8"
Stockschrauben-Schlüssel / Sanitary Wrench
Super TIN-Bits-Sortimente / Assortment of TIN-Bits

T

T-Griff mit 3/8" Aufnahme / T-Handle with 3/8"-couper
Trenngabeln / Separators
Türscharnier-Einsteckwerkzeug / Insert Door Hinge Wrench
Türscharnier-Knarrensatz / Door Hinge Ratchet Set

U

Universal-Radlagerwerkzeug-Satz / Universal Wheel Bearing Extractor Set

W

Winkelschraubendreher T-Griff / Hexagon Key Wrenches

Z

Zapfenschl. für Einspritzdüsen / Crow Socket for injection nozzles
Zylinderkopf -Schlüssel / Cylinder Head Wrench

Inhalt Index

Stichwortverzeichnis und numerischer
Index am Ende des Kataloges

Classified and numerical index
at the end of the catalogue



Module + Werkstattwagen
Modules + Trolleys

Werkstattwagen
Trolleys



Schlüssel
Wrenches

Schlüssel
Wrenches



Zangen
Pliers

Zangen
Pliers



Schraubendreher
Screwdrivers

Schraubendreher
Screwdrivers



Allgemeine Werkzeuge
Miscellaneous

Allgemeine Werkzeuge
Miscellaneous



Steckschlüssel
Socket Sets

Steckschlüssel
Socket Sets

MATADOR verbessert kontinuierlich die
aufgeführten Artikel. Aus diesem Grund
können einzelne Abbildungen bzw. techn.
Angaben von der gelieferten Ausführung abweichen.

MATADOR is always improving its products.
Therefore single illustrations and technical descriptions
in this catalogue might differ from the delivered articles.



Kfz-Spezialwerkzeuge
Automotive Tools

Spezialwerkzeuge
Automotive Tools

Alle Preisangaben sind in EURO ohne MwSt.
und gelten als unverbindliche Preisempfehlung.
All prices in EURO without VAT.



Sortimente
Assortments

Sortimente
Assortments

Über 100 Jahre MATADOR. More than 100 years of MATADOR.



Firmengründer / Founder
Heinrich Kissling



Früher Schmiedevorgang
Early Forging Process



Mitarbeiterstamm im Jahr 1907
Employees of MATADOR in 1907

MATADOR wurde im Jahre 1900 von Heinrich Kissling und Heiner Schumacher unter dem Namen "Schumacher & Kissling" gegründet.

MATADOR was founded in 1900 by Heinrich Kissling and Heiner Schumacher under the name of "Schumacher & Kissling".

Im Remscheider Morsbachtal begannen sie auf zwei wassergetriebenen Schmiedehämmern mit der Produktion von Zangen, Hämmern, Steckschlüsseln und Fahrradwerkzeugen. Noch heute befindet sich das Unternehmen an diesem traditionsreichen Standort im Bergischen Land.

In Remscheid-Morsbachtal, Germany, they started to produce pliers, hammers, box spanners and bicycle tools with the aid of just two water-powered forge hammers. The company has ever since been based in this traditional and picturesque hilly countryside.

Das Produktionsprogramm erweiterte sich schnell um Spezialwerkzeuge für die wachsende Automobilindustrie sowie um Steckschlüsseinsätze und Knarren. Bereits in den 1920er Jahren entstanden die MATADOR-Steckschlüsselgarnituren – eine Idee, die Heinrich Kissling von einer Studienreise aus den USA mitbrachte.

The product range expanded quickly and soon included special tools for the growing automotive industry as well as socket wrenches and ratchets. In this process the MATADOR socket sets were developed - an idea Heinrich Kissling brought with him from an educational trip to the USA.

Nach der völligen Zerstörung der Firmengebäude im II. Weltkrieg begann der Neuanfang am gleichen Standort. Bereits in den 1950er Jahren exportierte MATADOR wieder Werkzeuge in mehr als 30 Länder. In den Folgejahren wurde das Produktprogramm kontinuierlich weiter ausgebaut, so dass MATADOR sich einen festen Platz unter den etablierten deutschen Herstellern von Qualitäts-Handwerkzeugen erobert hat.

After a total destruction of the premises in World War II MATADOR had to be rebuilt. Nevertheless, already in the 1950s MATADOR tools were exported to more than 30 countries in the world. In the following decades many important product developments and investments were made resulting in the fact that today MATADOR ranks among the well-established German manufacturers of quality tools.

Auch heute noch befindet sich MATADOR in Familienbesitz und wird in vierter Generation von Peter Kissling geführt.

MATADOR is still lying in private hands and is now managed in fourth generation by Peter Kissling.

Seit / Since

1900



Heutige Firmenzentrale in Remscheid, Deutschland
MATADOR's headquarters in Remscheid, Germany

Das Produktprogramm von MATADOR besteht heute aus ca. 3.000 Standard- und Spezialwerkzeugen, die vorwiegend an den industriellen Profi-Anwender und die Kfz-Branche vertrieben werden.

MATADOR-Werkzeuge werden in über 90 Länder exportiert und namhafte Industrie- und Handelskunden vertrauen seit Jahren auf die Qualität von MATADOR.

Neben einem breiten Sortiment an Qualitätswerkzeugen fertigt MATADOR vorwiegend für die Automobilindustrie Spezialwerkzeuge und Sonderartikel nach Zeichnung an, die in den Werken selbst oder im After Market für kompliziertere Instandhaltungsaufgaben eingesetzt werden. Gerade die Zusammenarbeit mit der Großindustrie bedeutet das Einhalten höchster Qualitäts- und Prozessanforderungen, die MATADOR seit Jahren erfüllt.

Das dritte Standbein bei MATADOR ist der Bereich Private Label. Mittlerweile produziert MATADOR über 20 verschiedene Hersteller- und Handelsmarken. Die hohe Wertschöpfungstiefe am Standort Remscheid von der Schmiede über die eigene Härterei bis hin zur vollautomatischen Galvanik garantiert kontrollierbare Qualität und wirkliche Flexibilität, was viele Kunden zu schätzen wissen.

Our product range includes more than 3,000 standard and special hand tools which are mainly sold to professional industrial users and to the automotive sector.

MATADOR hand tools are exported to more than 90 countries and many well-known industrial and commercial customers trust in the quality of MATADOR.

Apart from a wide range of high quality hand tools, MATADOR manufactures special tools mainly for leading OEMs. These special tools are used for more complex work in maintenance areas or in the after market. The collaboration with big industrial customers in particular requires maximum quality and process excellence which MATADOR has now been able to meet for many years.

MATADOR's third commercial line is private label business. MATADOR meanwhile produces more than 20 different brands from manufacturers as well as big trading companies. The value chain of our own production line (from our own forging department to our own hardening plant up to a fully automatic galvanic system) guarantees controllable quality and flexibility which is highly appreciated by our customers.

Made in Germany.

Wir wissen wirklich was über Werkzeug.
We actually know a lot about hand tools.

Spezialwerkzeuge. Special Tools for Automotive and Industrial Users.

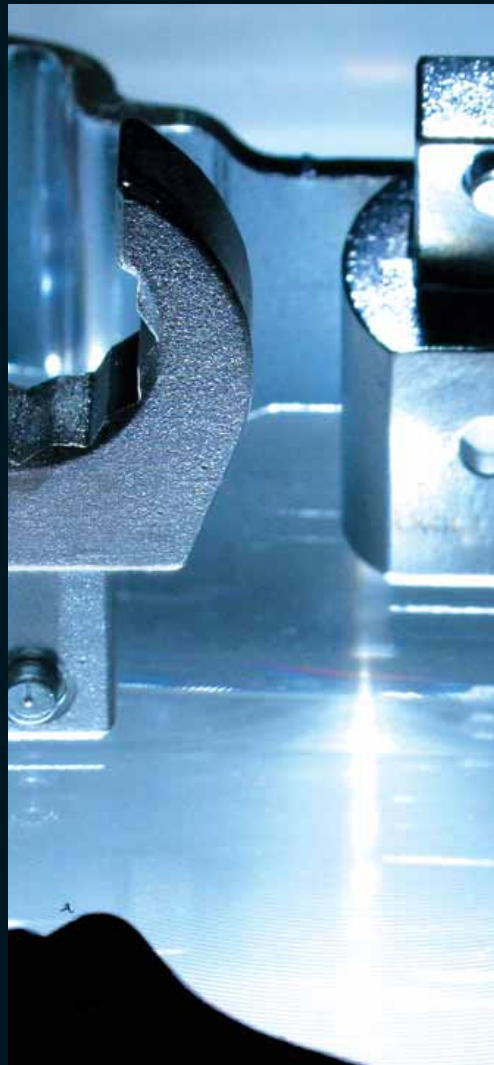

Durch unseren eigenen Werkzeugbau können wir schnell und unkonventionell Ihre Wünsche realisieren. Wir arbeiten mit modernen 2D- und 3D-CAD-Systemen und einen Prototyp Ihrer Sonderanfertigung erhalten Sie i.d.R. nach wenigen Tagen.

Nach DIN, Ihrer Zeichnung oder einem Muster fertigen wir Spezial-Werkzeuge sowie Warmstauchteile mit Materialstärken von 7-80mm, einem Stückgewicht von 50-6000g und einer Länge bis zu 1500mm.

Unsere Schmiedepressen arbeiten mit bis zu 500t Druckleistung. Dabei garantieren konduktive und induktive Erwärmungsanlagen mit elektronisch überwachter Temperatursteuerung die konstante zunderarme Erwärmung.

Thanks to our own tool development plant we can swiftly realize your wishes. We work with latest CAD-systems and normally you will receive a prototype of your custom-made product within a few days.

Based on your drawings or samples we manufacture special tools and hot forging parts with a thickness of 7-80mm, a weight of 50-6000g and a length of up to 1500mm.

Our forging presses have a pressure capacity of up to 500 tons. Conductive and inductive heating equipment with electronically supervised temperature control systems guarantee a steady and low-scale heating.

Private Label. Welt-Marken bei MATADOR. Private Label. World-known brands made by MATADOR.

MATADOR stellt auch für Sie Qualitätswerkzeuge her. In Deutschland. Am Standort Remscheid.

Mit über 300 eigenen Maschinen können folgende Fertigungsverfahren durchgeführt werden:

- Schmieden
- Räumen
- Drehen
- Bohren
- Fräsen
- Härten
- Sandstrahlen
- Trowalisieren
- Polieren
- Vernickeln / Verchromen / Verzinken

Oder aber wir besorgen Ihnen Werkzeuge, die wir nicht selbst herstellen können und greifen auf unser geprüf-tes, weltweites Lieferantennetzwerk zurück. Dann aber qualitätsgeprüft aus dem Blickwinkel eines zertifizierten Herstellers.

Gleichgültig, was Sie bevorzugen, MATADOR garantiert neben der gewohnten Qualität schnelle Lieferzeiten, kleine Mindestmengen (und dadurch geringere Lagerhaltungskosten für Sie), Flexibilität und letztendlich Sicherheit.

Profitieren Sie von unserem KnowHow, unserem Maschinenpark und unserem Service.

MATADOR is able to manufacture private label tools also for you. Made in Germany. Made in Remscheid.

With more than 300 own machines we provide the following machining operations:

- Forging
- Broaching
- Turning
- Boring
- Milling
- Hardening
- Sand blasting
- Vibra finishing
- Polishing
- Nickel / Chrome / Zinc plating

In any case in which our own production facilities are not suitable to produce a certain tool we can procure this tool from our network of suppliers. It goes without saying that also in this case - as a certified manufacturer - we attach great importance to an excellent quality.

Regardless of what you prefer, MATADOR stands for high quality products, short delivery periods, low minimum quantities (which in turn means lower storage costs for you), flexibility and last but not least safety.

Benefit from our know how, production facilities and our service.



Schmieden / Forging



Prägen / Stamping



Härten / Hardening



Verchromen / Chrome Plating

Sprechen Sie mit uns.
Talk with us.

Das Service- und Qualitätskonzept von MATADOR. How we understand service and quality.

Garantie. Guarantee.

Ehrlich gesagt, wir kennen Reklamationen kaum. Natürlich gewähren wir auf alle MATADOR-Werkzeuge volle Garantie, die wir nicht in Jahren ausdrücken.

Wir garantieren die sachgerechte Materialbeschaffenheit, die sorgfältige mechanische Bearbeitung und Oberflächenbehandlung der Produkte. Alle MATADOR-Werkzeuge übertreffen die in DIN-/ISO-Normen geforderten Belastungswerte und bieten so Sicherheitsreserven im täglichen Umgang. Und falls trotzdem etwas nicht so ist wie es sein sollte, helfen wir schnell und unbürokratisch.

To put it bluntly: we are really short with experience on claims. But of course we offer a full guarantee on all MATADOR tools, and we do not count it in years.

We guarantee the appropriate quality of materials, the thorough mechanical processing and surface treatment of the products. All MATADOR tools exceed the load levels required by the DIN-/ISO-standards and as a result offer extra safety in their daily use. Should nevertheless be anything wrong we will find an unbureaucratic way to help you.

Service. Service.

Unser Ziel ist es, eine perfekte Dienstleistung anzubieten, die sich nicht allein in gutem Werkzeug äußert, sondern auch in perfektem Service widerspiegelt.

Perfekter Service bedeutet für uns zum Beispiel, motivierte und hochqualifizierte Mitarbeiter zu beschäftigen, die anhand modernster IT die Voraussetzungen für wirkliche Prozesseffizienz schaffen. Mit fast allen unserer Großkunden sind wir über edifact, Web-EDI usw. verbunden. Aufträge werden von einem Sales Service-Team so schnell bearbeitet, dass wir unserem Ziel, Ihnen 100% (und nicht 99%) unserer Katalogartikel in 24h zu liefern, jeden Tag näher kommen.

Our goal is to offer a perfect service, evidenced not only by supplying good tools but also by offering fast and convincing solutions.

For us perfect service means for example that we engage highly motivated and experienced personnel and provide them with the latest IT solutions to set the stage for real process efficiency. Most of our main customers are connected to us via Edifact, Web-EDI etc. Every day we come along with our goal to deliver 100% (and not only 99%) of the items shown in this catalogue within 24 hours.

Qualität. Quality.

MATADOR ist schon lange zertifiziert nach DIN EN ISO 9001:2000. Management, Organisation und Fertigungsprozess unterliegen daher einem strengen Qualitätssicherungs-System.

Jeder Mitarbeiter ist für seinen Arbeitsplatz und seine Tätigkeit selbst verantwortlich, so dass jede Stufe der Fertigung einer ständigen Sicherung unterliegt. Zusätzlich optimieren wir in kleinen Arbeitsgruppen laufend unseren Fertigungsprozess, damit wir unsere Qualität Schritt für Schritt noch weiter steigern. KVP, Kanban, BestPractices usw. sind bei uns keine Fremdworte, sondern werden gelebt. Jeden Tag.

MATADOR is certified according to DIN EN ISO 9001:2000. This means that the company's management, organization and manufacturing processes are subject to a strict quality assurance system.

Each employee is responsible for his/her workplace and activities, making sure every step of production is constantly monitored. In addition, we have small work groups in charge of optimizing our manufacturing processes in order to continue to increase our quality step by step. For us, CIP, Kanban, BestPractices etc. are no buzzwords, we put them into real practice. Every day.

DIN EN ISO 9001:2000



Inhalt Index

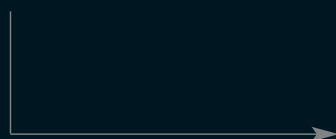

Module + Werkstattwagen Modules + Trolleys



A. Basic-Line

Basic-Line ist die Einstiegsklasse der MATADOR-Werkstattwagen. 3 Modelle, die unterschiedliche Schwerpunkte setzen, aber hinsichtlich Volumen, Preis und Anwendungsgebiet vergleichbar sind.

So ist der **Compact** ein alter Klassiker, den wir in dieser Ausführung schon sehr lange im Programm haben. Zielgruppe sind Industriebetriebe, Handwerker, und Kfz-Werkstätten, die nur wenige Werkzeuge aufbewahren möchten und lieber einen kleinen, wendigen Werkstattwagen suchen. So wird der Compact auch sehr häufig als stationärer Instandhaltungswagen in einzelnen Fertigungsbereichen eingesetzt.

Der **Quadro** ist etwas größer als der Compact und bietet fast die gleichen Funktionen wie seine großen Brüder Servant und Combi, nur etwas kompakter. Mit seinem fast quadratischen Korpus nimmt er wenig Platz ein und ist der ideale stationäre Werkzeugwagen. Durch die 10 x 10mm-Lochung kann er mit fast unbegrenzten Zubehörteilen sehr individuell ausgestattet werden.

Der **Servant** ist ein schmaler, hoher Wagen, der häufig in Kfz-Werkstätten eingesetzt wird. Er passt ideal zwischen mehrere Hebebühnen und spielt seine Stärken vor allen Dingen bei beengten Platzverhältnissen aus. Durch seine hohe Wendigkeit und das breite Fahrwerk ist er sehr mobil einsetzbar.

Basic-Line is the access class of MATADOR trolleys. We offer 3 types which have a different main focus, but are similar regarding volume, price and application area.

Compact is a classical trolley we have already had in our program for a very long time. The target groups are industrial companies, craftsmen and workshops that prefer to store only few tools and look for small and agile trolleys. Thus, Compact is used frequently as a stationary maintenance trolley in different areas of production.

Quadro is larger than Compact and offers nearly the same luxurious functions as its big brothers Servant and Combi. With its almost square body it requires less space and is the ideal stationary trolley. Thanks to its 10 x 10mm perforated side walls, it can be individually equipped with almost unlimited accessories.

Servant is a slim and tall trolley which is frequently used in workshops. It fits ideally between lifting platforms and shows its advantages mainly in limited and narrow spaces. Due to its high agility and large chassis it is applicable in many variable ways.



Werkstattwagen "Compact"
Workshop Trolley "Compact"



Basic-Line

Compact.

Einstiegsmodell "Compact", mit 4 kugellagerten, beidseitig ausziehbaren Schubladen, davon 2 Schubladen mit festen Unterteilungen, Mitten- und Endarretierungen, 2 Metalljalousien mit Zentralverschluss, Stoßschutz, verstärkte Breitspur-Hinterachse, 2 lenkbare Vorderräder (100mm Durchmesser), 1 Rad davon mit Bremse und Totalstopp, 2 feststehende Räder (140mm Durchmesser).

Basic model "Compact" with 4 drawers to be pulled on both sides (opens 2/3), 2 of them subdivided; running on ball-bearings; center click-stop; safety system against pulling out; two metal shutter doors with lock; 2 rubber perimeter bands; fixed bow; 2 mobile wheels (100mm) - 1 of them with parking brake and 2 fixed wheels (140mm).

Technische Daten Technical details	Maße Measurements	
Außenmaß (LxBxH) Outside dimens. (LxWxH)	660 x 390 x 920mm	
Volumen Volume	236l	
Innenmaß Schublade Inside dim. of drawers	525 x 325 x 40mm	
Schubladenunterteilung Separation of drawers	Schublade 1+2 fest unterteilt (3/3), Rest offen / Drawer 1+2 separated (3/3), the others flexible	
Gewicht leer Weight empty	37kg	Art.-Nr. / No. 8159 0020
Verfügbare Module Available module systems	ABS Mini	€ 299,-

Quadro.

Basic-Line

Einstiegsmodell "Quadro", stabile Konstruktion, sehr hoch belastbar, 2 Lenkräder (100mm Durchmesser) und 2 Bockrollen (125mm), 7 Schubladen, einseitig voll ausziehbar, Längsteiler flexibel einsetzbar, Einzelverriegelung der Schubladen und dadurch kein Öffnen während der Fahrt, herausnehmbare Schubladen, Zentralverriegelung aller Schubladen durch Sicherheitszylinderschloß, Arbeitsplatte aus ABS-Kunststoff mit Ablagefächern für Kleinteile, stabiler Kunststoffgriff, Seiten- und Rückwandlochung (10x10mm) für Zubehör.

Basic model "Quadro", 7 drawers, central locking system; high loading capacity; each drawer with safety lock; no uncontrolled opening during transport; ball-bearing strips; top plastic cover with separations; 2 stable and 2 mobile wheels (100 mm / 125 mm); reciprocal handle for simplified operations; hole cover (10x10mm) on side and back parts of the trolley for accessories.

Technische Daten Technical details	Maße Measurements	
Außenmaß (LxBxH) Outside dimens. (LxWxH)	600 x 440 x 940mm	
Volumen Volume	248l	
Innenmaß Schublade Inside dim. of drawers	5x: 442x350x80, 2x: 442x350x160mm	
Schubladenunterteilung Separation of drawers	Flexibel durch Längsteiler Flexible due to separating strips	
Gewicht leer Weight empty	45kg	Art.-Nr. / No. 8162 0020
Verfügbare Module Available module systems	ABS Mini / ModuFlex	€ 379,--

Werkstattwagen "Quadro"
Workshop Trolley "Quadro"



Werkstattwagen
Trolleys

Servant.

Basic-Line

Werkstattwagen "Servant" mit 6 kugelgelagerten, einseitig ausziehbaren Schubladen, angenehme Arbeitshöhe, sehr wendig, Einzelschubladen-Verriegelung, stabiler Metallgriff, Seitenwand mit Eurolochung, Zentralverschluß, verstärkte Breitspur-Hinterachse mit 2 stabilen Gummirädern (Durchmesser 150mm), 2 lenkbare Vorderräder (Durchmesser 100mm), 1 Rad davon mit Bremse und Totalstopp.

Trolley "Servant" with six drawers to be pulled on one side; very comfortable height; drawers running on ball-bearings; each drawer with safety lock; no uncontrolled opening during transport; metal handle; fixed bow; 2 mobile wheels (100mm) - one of them with parking brake - and 2 stable wheels (150mm).

Technische Daten Technical details	Maße Measurements	
Außenmaß (LxBxH) Outside dimens. (LxWxH)	720 x 380 x 925mm	
Volumen Volume	253l	
Innenmaß Schublade Inside dim. of drawers	4x: 495x335x70, 1x: 495x335x110, 1x: 495x335x170mm	
Schubladenunterteilung Separation of drawers	Keine / None	
Gewicht leer Weight empty	50kg	Art.-Nr. / No. 8158 0020
Verfügbare Module Available module systems	ABS Mini / MTS / ModuFlex	€ 448,--

Werkstattwagen "Servant"
Workshop Trolley "Servant"



Module / Modules

Stellen Sie sich Ihren eigenen Wagen zusammen. Seite kopieren, Wagen und Module ankreuzen und Ihrem Fachhändler geben - oder an MATADOR schicken.

Art.-Nr./No.	X
--------------	----------

Arrange your own workshop trolley. Just copy this double page, mark your trolley and the modules you require and send it to your dealer or to MATADOR.

ABS Mini.

Passend für / Fits in
Compact.

Compact



ABS Mini 155 x 320	ABS Mini 155 x 320	ABS Mini 155 x 320
Schubladen-Innenmaß Drawer inside measurements 525 x 325mm		

Passend für / Fits in
Quadro.

Quadro



ABS Mini 155 x 320	ABS Mini 155 x 320	ABS Mini 155 x 320
Schubladen-Innenmaß Drawer inside measurements 442 x 350 mm		

Doppelmaulschlüssel
Double Open Ended Spanners

6 x 7, 8 x 9, 10 x 11, 12 x 13,
14 x 15, 16 x 17, 18 x 19,
20 x 22mm

Art.-Nr. / No.	⚖️	X	EUR
0105 4043	900		29,50
8-tlg. / pcs.			

Ringmaulschlüssel, DIN 3113 A
Ring Jaw Wrenches, DIN 3113 A

8, 10, 11, 13, 14, 17, 19, 22mm

Art.-Nr. / No.	⚖️	X	EUR
0185 4042	950		36,50
8-tlg. / pcs.			

Ringratschenschlüssel, VA-Stahl
Ring Ratchet Spanners, stainless

8, 10, 11, 13, 14, 17, 19mm

Art.-Nr. / No.	⚖️	X	EUR
0186 4042	1200		95,--
7-tlg. / pcs.			

Ringmaulschlüssel, DIN 3113 B
Ring Jaw Wrenches, DIN 3113 B

8, 10, 11, 13, 14, 17, 19mm

Art.-Nr. / No.	⚖️	X	EUR
0190 4011	750		43,--
7-tlg. / pcs.			

Doppelringschlüssel, DIN 838
Double Ended Ring Spanners

6 x 7, 8 x 9, 10 x 11, 12 x 13,
14 x 15, 16 x 17, 18 x 19mm

Art.-Nr. / No.	⚖️	X	EUR
0205 4044	1050		43,--
7-tlg. / pcs.			

Gerade Doppelringschlüssel
Flat Double Ended Ring Spanners

8 x 9, 10 x 11, 12 x 13, 14 x 15,
16 x 17, 18 x 19, 20 x 22,
24 x 27mm

Art.-Nr. / No.	⚖️	X	EUR
0220 4001	700		44,--
8-tlg. / pcs.			

Ringratschenschlüssel
Ring Ratchet Spanners

8 x 9, 10 x 11, 12 x 13,
14 x 15, 17 x 19mm

Art.-Nr. / No.	⚖️	X	EUR
0224 4042	800		59,--
5-tlg. / pcs.			

Offene Ringschlüssel
Flare Nut Ring Spanners

8 x 10, 10 x 12, 11 x 13, 14 x 17,
16 x 18, 17 x 19, 22 x 24mm

Art.-Nr. / No.	⚖️	X	EUR
0251 4001	1050		70,--
7-tlg. / pcs.			

Zangen
Pliers

(500) 185mm
(530) 180mm
(585) 200mm

Art.-Nr. / No.	⚖️	X	EUR
0500 4001	900		49,--
3-tlg. / pcs.			

VDE-Zangen
VDE-Pliers

(500) 180mm
(532) 160mm
(585) 205mm

Art.-Nr. / No.	⚖️	X	EUR
0501 4001	1000		59,--
3-tlg. / pcs.			

Zangen
Pliers

(500) 185mm
(530) 180mm
(556) 240mm

Art.-Nr. / No.	⚖️	X	EUR
0556 4001	1000		46,--
3-tlg. / pcs.			

Sicherungsring-Zangen
Circlip Pliers

(578) A2
(580) A21
(582) J2
(584) J21

Art.-Nr. / No.	⚖️	X	EUR
0578 4002	700		46,--
4-tlg. / pcs.			

Schraubendreher
Screwdrivers

(615) 4x75, 5x100, 5.5x125, 6.5x150mm; (655) PH 1+2, (655) PH 2x25, (640) 6.5x25

Art.-Nr. / No.	⚖️	X	EUR
0615 4001	600		29,--
8-tlg. / pcs.			

VDE-Schraubendreher
VDE-Screwdrivers

(616) 2,5 x 75; 3,5 x 100, 5,5 x 125; 6,5 x 150 (656) PH 1+2

Art.-Nr. / No.	⚖️	X	EUR
0616 4001	650		25,--
6-tlg. / pcs.			

TORX-Schraubendreher
TORX-Screwdrivers

(620)TX 15, TX 20, TX 25, TX 27, TX 30, TX 40

Art.-Nr. / No.	⚖️	X	EUR
0620 4001	600		31,--
6-tlg. / pcs.			

Werkzeug-Satz
Tool Set

(705) 300g, (714) 150 x 18, 200 x 24, (717) 120 x 4mm, (718) Ø 3, 4, 5, 6mm

Art.-Nr. / No.	⚖️	X	EUR
0705 4002	1450		35,--
8-tlg. / pcs.			

1/4"-Steckschlüssel-Garnitur
1/4"-Socket Set

(2061), (2064), (2065), (2066), (2068), (2073), (2075) 4; 4,5; 5; 5,5; 6; 7; 8; 9; 10; 11; 13mm, (2076) 4; 5,5; 7mm, (2077) No. 1; 2; 3, (2078) 3; 4; 5; 6; 8

Art.-Nr. / No.	⚖️	X	EUR
2136 4011	700		85,--
28-tlg. / pcs.			

1/4"-TORX-Garnitur
1/4"-Socket Set TORX

(2061), (2064), (2065), (2066), (2068), (2073), (2075) 4; 4,5; 5; 5,5; 6; 7; 8; 9; 10; 11; 13mm, (2090) E 4; 5; 6; 7; 8; 10; 11, (2092) TX 8; 10; 15; 20; 25; 27; 30; 40

Art.-Nr. / No.	⚖️	X	EUR
2136 4012	700		90,--
32-tlg. / pcs.			

3/8"-Steckschlüssel-Garnitur
3/8"-Socket Set

19-tlg. / pcs.
(3061), (3064), (3065), (3066), (3068), (3075) 6; 7; 8; 9; 10; 11; 13; 14; 16; 17; 18; 19; 20; 22mm

Art.-Nr. / No.	⚖️	X	EUR
3115 4002	1600		90,--
3115 4001	1600		

1/2"-Steckschlüssel-Garnitur
1/2"-Socket Set

17-tlg. / pcs.
(4060), (4065), (4066), (4075) 10; 11; 12; 13; 14; 15; 16; 17; 18; 19; 20; 21; 22; 24mm

Art.-Nr. / No.	⚖️	X	EUR
4105 4014	2300		80,--
4105 4011	2300		

1/2"-Schraubendreher-Einsätze
1/2"-Screwdriver Sockets

(4078) 5, 6, 8, 10 x 60mm, (4079) 6, 8, 10, 12 x 100mm, (4092) TX 30, 40, 45, 50 x 60mm

Art.-Nr. / No.	⚖️	X	EUR
4078 4001	1150		72,--
12-tlg. / pcs.			

1/2"-TORX-Einsätze
1/2"-Sockets for TORX screws

25-tlg. / pcs.
TX 20, 25, 27, 30, 40, 45, 50, 55, 60; E 10, 12, 14, 16, 18, 20, 24 + TX 9 - TX 40 Stiftschlüssel / Allen Keys

Art.-Nr. / No.	⚖️	X	EUR
4092 4001	1600		110,--
4092 4002	1600		

Distanzmodul quer Servant
Distance Module across Servant

Servant: 1x pro Schublade benötigt
Servant: Use 1x per drawer

340 x 25mm

Art.-Nr. / No.	⚖️	X	EUR
8158 0096	40		3,50

Distanzmodul längs Servant
Distance Module along Servant

Servant: 1x pro Schublade benötigt
Servant: Use 1x per drawer

150 x 33mm

Art.-Nr. / No.	⚖️	X	EUR
8158 0095	5		1,50

Ersatz-Module
Empty modules

Art.-Nr. / No.	Passend für / Suitable for	Einzelpreis / Each
0190 40 95	105, 185, 186, 190, 220, 224, 251	
0205 40 95	200	
0500 40 95	500, 501, 556	
0578 40 95	578	
0615 40 95	615, 616, 620	
0705 40 95	705	
2135 40 95	2135, 2136	
3115 40 95	3115	
4078 40 95	4078	6,50
4092 40 95	4092	
4105 40 95	4105	

Leer-Modul Quadro
Empty module for Quadro

Pro Schublade 1 Leermodul erforderlich
1 module per drawer required

132 x 320mm

Art.-Nr. / No.	⚖️	X	EUR
8162 0095	20		9,50

Passend für / Fits in
Servant.

8158 00 96

ABS Mini	ABS Mini	ABS Mini
155 x 320	155 x 320	155 x 320

Schubladen-Innenmaß
Drawer inside measurements
495 x 335mm

Pakete / Package Deals

Compact Servant ABS 75-tlg./pcs.



Gratis / free:



Art.-Nr. / No.	Compact	EUR
8159 0056	75-tlg. / pcs.	598,--
8159 0076		

Art.-Nr. / No.	Servant	EUR
8158 0055	75-tlg. / pcs.	748,--
8158 0075		

Ringmaulschlüssel, DIN 3113 B
Ring Jaw Wrenches, DIN 3113 B



8, 10, 11, 13, 14, 17, 19mm

Art.-Nr. / No.	750	EUR
0190 4011	750	36,50
7-tlg. / pcs.		

Zangen
Pliers



(500) 185mm
(530) 180mm
(556) 240mm

Art.-Nr. / No.	1000	EUR
0556 4001	1000	46,--
3-tlg. / pcs.		

Schraubendreher
Screwdrivers



(615) 4x75, 5x100, 5.5x125,
6.5x150mm; (655) PH 1+2, (655)
PH 2x25, (640) 6.5x25

Art.-Nr. / No.	600	EUR
0615 4001	600	29,--
8-tlg. / pcs.		

Werkzeug-Satz
Tool Set



(705) 300g, (714) 150 x 18, 200 x 24,
(717) 120 x 4mm,
(718) Ø 3, 4, 5, 6mm

Art.-Nr. / No.	1450	EUR
0705 4002	1450	35,--
8-tlg. / pcs.		

1/4"-TORX-Garnitur
1/4"-Socket Set TORX



(2061), (2064), (2065), (2066), (2068),
(2073), (2075) 4; 4,5; 5; 5,5; 6; 7; 8; 9;
10; 11; 13mm, (2090) E 4; 5; 6; 7; 8;
10; 11, (2092) TX 8; 10; 15; 20; 25; 27;
30; 40

Art.-Nr. / No.	700	EUR
2136 4012	700	90,--
32-tlg. / pcs.		

1/2"-Steckschlüssel-Garnitur
1/2"-Socket Set



17-tlg. / pcs.
(4060), (4065), (4066), (4075)
10; 11; 12; 13; 14; 15; 16; 17;
18; 19; 20; 21; 22; 24mm

Art.-Nr. / No.	2300	EUR
4105 4014	2300	80,--
4105 4011		

ABS

Quadro MTS Q

139-tlg./pcs.

- Entnehmbares 1/4"- und 1/2"- Modul für dezentralen Einsatz - "ModuFlex"

- Removeable 1/4"- and 1/2"-module for mobile use "ModuFlex"



Werkstatwagen
Trolleys

Gratis / free:



Gratis / free:



Gummihammer 500g
Rubber mallet

Gratis / free:



Reifenmontierhebel
Tyre lever

Doppelmaul-/ Ringmaulschlüssel Set of Spanners



- DIN 3110 6x7 - 30x32mm
- DIN 3113 B 10-14, 17, 19, 22, 24, 27, 30, 32mm

Art.-Nr. / No.	X	EUR
8162 6001	5000	125,-
24-tlg. / pcs.		

Doppelringsschlüssel-Satz Set of Ring Spanners



- DIN 838 6x7, 8x9, 10x11, 12x13, 14x15, 16x17, 18x19, 20x22, 21x23, 24x27, 25x28, 30x32mm

Art.-Nr. / No.	X	EUR
8162 6002	3250	95,-
12-tlg. / pcs.		

Mechaniker-Satz Set of mechanic tools



- Schlosserhammer / Locksmith Hammer 500 + 1000g
- Flachmeißel / Flat Cold Chisel 200mm
- Splintreiber-Satz / Set of parallel punches 2, 3, 4, 5, 6, 8mm
- Feilen-Satz / Set of files
- Stahldrahtbürste mit 5 Reihen / Steel Wire Brush with 5 rows
- Dichtungsschaber / Scraper 250mm
- Abbrechmesser / Cutter 18mm

Art.-Nr. / No.	X	EUR
8162 6005	3800	95,-
19-tlg. / pcs.		

Zangen-/Schraubendreher-Satz Set of Screwdrivers and Pliers



- 9-tlg. Satz 6-kt-Winkelschraubendreher / Set of Allen Keys, 9-pcs. 1,5-10mm
- Kraft-Kombinationszange / Combination Plier 6.1/2" - 165mm
- Seitenschneider / Side Cutting Nipper 6.1/4" - 160mm
- Wasserpumpenzangen / Water Pump Pliers 240 + 300mm
- Schraubendreher mit Holzheft und Schlagkappe / Screwdrivers with wooden handle 3,5x75mm, 5,5x100mm, 7x125mm
- Philips Recess PH 1, 2
- 2K-Schraubendreher / 2C-Screwdrivers
- TORX TX 10, 15, 20, 25, 30, 40

Art.-Nr. / No.	X	EUR
8162 6004	2450	135,-
24-tlg. / pcs.		

1/4"- und 1/2"-TORX-Satz 1/4" - 1/2"-TORX Socket Set



- Umschaltknarren mit Sicherheitsverbindung / Ratchets with safety lock (2061+4061)
- 58-tlg. / pcs.

1/4":

	2061		4; 4,5; 5,5; 6; 6-11; 13mm
	115mm		E 4; 5, 6, 7; 8; 10; 11
	50,100		TX 8; 10; 15; 20; 25; 27; 30; 40
	2068		

1/2":

	4061		10-19; 22; 24; 27; 30; 32mm
	300mm		E 10; 12; 14; 18
	75, 250mm		TX 45; 50; 55; 60 x 60mm
	2068		

Art.-Nr. / No.	X	EUR
8162 6003	4300	225,-
8162 6006	4300	

MTS - System

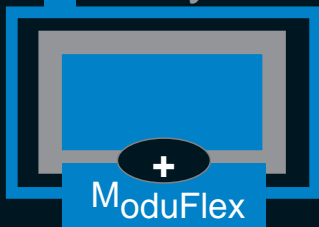

B. Profi-Line

Profi-Line ist die Werkstattwagenklasse für diejenigen Anwender, die täglich mit Werkzeug arbeiten. Diesen Nutzern muss es schnell gehen, der Wagen muss viel Stauraum bieten, idealerweise Zusatzfächer für Zubehör und Kleinteile haben, er muss stabil sein, mit hoher Zuladung und trotzdem noch mobil genug, um ihn jederzeit an einem anderen Ort einzusetzen, und, und, und... MATADOR bietet 3 Modelle in der Profi-Line an, die zu unseren Rennern gehören:

Der **Multi** verfügt über 7 Schubladen und jede Menge Stauraum. Das Besondere an ihm ist, dass sich die Schubladen von beiden Seiten öffnen lassen. Dies hat den Vorteil, dass 2 Arbeitsplätze gleichzeitig vom Multi aus bedient werden können. Haupteinsatzbereich sind demzufolge Kfz-Werkstätten.

Das Modell **Combi** ist seit mehreren Jahren unser erfolgreichster Werkstattwagen. Dieser Klassiker hat sich viele Freunde gemacht und wird von uns unverändert angeboten. Mit 6 vollausziehbaren Front- und 2 Seiten-Schubladen ist er besonders im Kfz-Bereich gefragt.

Für diejenigen, die den Combi lieb gewonnen haben, aber nicht auf Innovationen verzichten möchten, haben wir den **Combi-Plus** entwickelt. Mit Flankenschutz, einzeln verriegelbaren Schubladen, einem stabilen Griff und einer eingefassten ABS-Arbeitsplatte ist er der ideale Begleiter.

Profi-Line is the category of workshop trolleys for those who work with tools daily. For these users everything must go fast. The trolley must offer enough storage and supplementary space for accessories and small items. In addition it must be stable and have high extra load capacity. However, it must remain mobile enough in order to use it at any time and any place, and, and, and... MATADOR offers 3 models in this Profi-Line:

Multi has 7 drawers and lots of load capacity. The drawers can be opened from both sides. This has the advantage that 2 persons can use the tools of the trolley at the same time. Therefore, its main application areas are workshops.

For several years the model **Combi** has been our most successful workshop trolley. This classical trolley is very popular and MATADOR is still offering it in the same traditional version. With fully extendable front drawers and 2 side drawers, it is particularly in demand in the automotive sector.

For those who appreciate the advantages of our Combi but at the same time do not want to miss the latest innovations, we developed **Combi-Plus**. With side protection, individually lockable drawers, a robust metal grip and a new worktop in ABS plastic, we can say: Combi-Plus is the ideal companion.

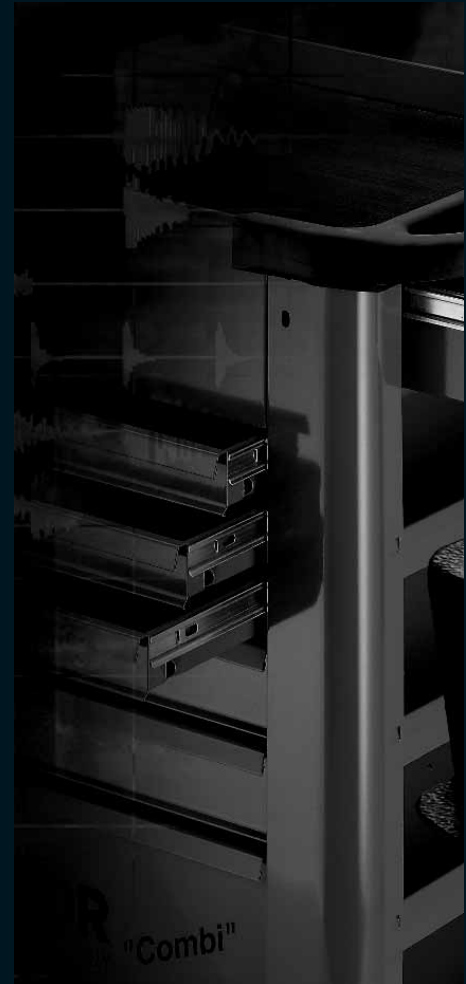

Werkstattwagen "Multi"
Workshop Trolley "Multi"

Multi.



Profi-Line

Werkstattwagen "Multi" mit großer Arbeitsfläche und gerillter Gummimatte, 8 kugelgelagerte, beidseitig ausziehbare Schubladen, jeweils zu 2/3 ausziehbar, Mitten- und Endarretierung, Zentralverriegelung, 1 Seitenwand mit Euro-Schlüssellochung, 1 Seitenwand mit 4 Ablagefächern, 2 lenkbare Vorderräder (100mm Durchmesser), 1 Rad davon mit Bremse und Totalstopp, 2 Bockrollen (120mm Durchmesser).

Trolley "Multi" with large working top and grooved rubber mat; 8 drawers running on ball bearings, to be pulled to 2/3 on both sides; center click stop. Central cylinder lock system; 1 perforated side wall with round end key holes; 1 side wall with 4 compartments. Load capacity 40 kg per drawer. 2 mobile wheels (100mm) and 2 fixed wheels (120mm).

Technische Daten Technical details	Maße Measurements	
Außenmaß (LxBxH) Outside dimens. (LxWxH)	890 x 485 x 870mm	
Volumen Volume	375l	
Innenmaß Schublade Inside dim. of drawers	4x: 566x415x50, 3x: 566x415x65, 1x: 566x415x170mm (LxBxH / LxWxH)	
Schubladenteilung Separation of drawers	Keine / None	
Gewicht leer Weight empty	56kg	Art.-Nr. / No. 8157 0020
Verfügbare Module Available module systems	ABS Maxi / MTS / ModuFlex	€ 498,--

Combi.

Werkstattwagen "Combi"
Workshop Trolley "Combi"



Profi-Line

Unser Erfolgsmodell "Combi" mit großer Arbeitsfläche und 6 einseitigen, kugelgelagerten und vollausziehbaren Frontschubladen. Zusätzlich je 1 Schublade und 4 Ablagefächer beidseitig, 3 davon verstellbar. Schubladen mit Ausziehschutz (Gummistopper) gegen unbeabsichtigtes Öffnen. Mit Zentralverriegelung. Feststehender Kunststoffbügel; keine Kanten zum Schutz vor Verletzungen und Kratzern. Unterste Schublade mit Doppelschienenführung, extrem belastbar. 2 lenkbare Vorderräder (100mm Durchmesser), 1 Rad mit Bremse und Totalstopp, 2 Bockrollen (120mm).

Our running item "Combi" with large working top and 6 single front drawers, plus 1 drawer and 4 compartments on both sides, 3 of them adjustable. Drawers fully extendable. Load capacity 40kg per drawer. Centrally locked by cylinder lock. Mobile wheel (100mm) with parking brake, fixed bow. Stable wheel (120mm). Bottom drawer with double slides, extremely high loading capacity.

Technische Daten Technical details	Maße Measurements	
Außenmaß (LxBxH) Outside dimens. (LxWxH)	890 x 485 x 860mm	
Volumen Volume	371l	
Innenmaß Schublade Inside dim. of drawers	3x: 566x415x45, 2x:566x415x70, 1x: 566x415x170mm (LxBxH / LxWxH)	
Schubladenunterteilung Separation of drawers	Keine / None	
Gewicht leer Weight empty	56kg	Art.-Nr. / No. 8156 0020
Verfügbare Module Available module systems	ABS Maxi / MTS / ModuFlex	€ 498,--



Combi Plus.

Werkstattwagen "Combi Plus"
Workshop Trolley "Combi Plus"



Profi-Line

Wie Combi, jedoch zusätzlich mit 4-seitigem Flankenschutz. Ablagefläche sehr stabil mit zusätzlichen Unterteilungen. Einzelverriegelung der Schubladen (kein unbeabsichtigtes Öffnen mehr). Stabiler Kunststoffgriff.

Same as "Combi", but additionally with four protection strips; ABS worktop; each drawer with safety lock; no uncontrolled opening during transport; load capacity 40kg per drawer; metal handle.

Technische Daten Technical details	Maße Measurements	
Außenmaß (LxBxH) Outside dimens. (LxWxH)	890 x 485 x 860mm	
Volumen Volume	371l	
Innenmaß Schublade Inside dim. of drawers	3x: 566x415x45, 2x: 566x415x70, 1x: 566x415x170mm (LxBxH / LxWxH)	
Schubladenunterteilung Separation of drawers	Keine / None	
Gewicht leer Weight empty	62kg	Art.-Nr. / No. 8156 0021
Verfügbare Module Available module systems	ABS Maxi / MTS / ModuFlex	€ 568,--



C. Industrial-Line

Industrial-Line richtet sich hauptsächlich an industrielle Abnehmer, die große, geräumige Werkstattwagen mit viel Stauraum benötigen. Erfolgskriterien sind neben dem Volumen vor allen Dingen groß dimensionierte Reifen, Abschließbarkeit, leichte Transportfähigkeit und eine hohe Zuladung. Werkstattwagen der MATADOR Industrial-Line werden vorzugsweise in Instandhaltungsbereichen großer Industrieunternehmen eingesetzt, wo die Anwender innerhalb eines Werks mobil sein müssen und ihr Arbeitsgerät zum Einsatzort mitnehmen. Hier kommt es weniger auf die perfekte Werkzeugordnung an, sondern eine hohe Flexibilität ("möglichst viel reinpacken") ist ausschlaggebend.

Der **Maxi** ist der größte Werkstattwagen aus dem MATADOR-Programm. Mit seinen 7 Schubladen bietet er umfangreichen Stauraum und kann ebenfalls ringsherum erweitert werden. Einzelverriegelung der Schubladen sind ebenso selbstverständlich wie eine voll variable Schubladeneinteilung.

Der **Flexi** ist eine vollkommene Neuentwicklung und bietet mit 3 offenen Fächern und 2 Schubladen vielfältige Aufbewahrungsmöglichkeiten. Mit seiner Arbeitsfläche von 1.030mm ist er als mobile Werkbank geeignet und kann mit Multifaserplatte und Schraubstock ausgestattet werden. An die Lochwände passt von außen vielfältiges Zubehör, so dass der Anwender hier über eine richtige "Work Station" verfügt. Dank seiner 160er Gummireifen ist er sehr leichtgängig und auch im unwegsamen Gelände problemlos zu bewegen.

Industrial-Line is addressed mainly to industrial customers, who need large and roomy workshop trolleys with much loading capacity. The success criteria are - in addition to maximum volume - large tires, lockable drawers, easy transportability and high additional load capacity. MATADOR Industrial-line trolleys are preferably used in maintenance areas of big industrial companies where users have to move between different areas. We call this: "carry all your tools to every place where they are needed". In this case it depends less on the perfect organization of the tools, but more on high flexibility.

Maxi is the largest workshop trolley in the MATADOR program. With its 7 drawers it offers extensive storage space and can also be extended by a full variety of accessories. Of course, Maxi is equipped with single locking and a perfect and variable organization system in the drawers.

Flexi is a new development which offers various storage possibilities due to its 3 open compartments and 2 drawers. Thanks to its working surface with a height of 1,030mm it can be used as a mobile work bench and can be equipped with a multi-fibre worktop and a vice. Due to its perforated side panels various accessories can be added, so that users have a real "workstation" at their disposal. Thanks to its 160mm rubber tires it can easily be moved even in hard working areas.

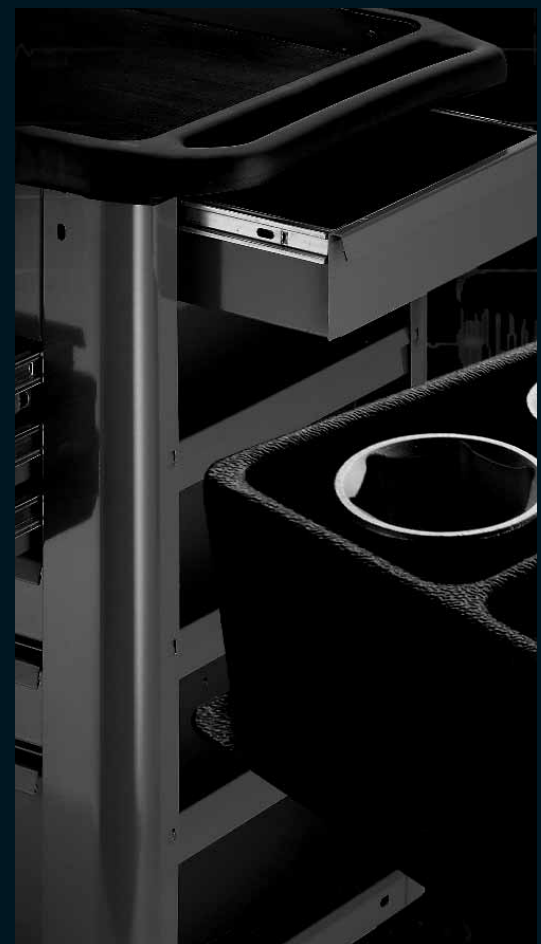

Werkstattwagen "Maxi"
Workshop Trolley "Maxi"



Industrial-Line

Maxi.

Modell "Maxi" mit 7 Schubladen; schwere Stahlblechkonstruktion; sehr belastbar; vier große Räder (125 mm); Doppelstopprad; Teleskopschienen; Vollauszug der Schubladen, herausnehmbar; Einzelverriegelung, kein unbeabsichtigtes Öffnen; variable Einteilmöglichkeit der Schubladen; Zentralverriegelung; stabile Arbeitsplatte aus ABS-Kunststoff mit Ablagefächern für Dosen, Kleinteile usw.; Seitenwände und Rückwand mit Lochung (10 x 10) für Zubehör.

Model "Maxi" with 7 drawers; heavy steel construction; high capacity; 2 stable and 2 mobile wheels (125 mm); two parking brakes; drawers running on ball bearings; central cylinder lock system; each drawer with safety lock, no uncontrolled opening during transport; possibility to separate the drawers with metal strips; worktop with compartments for accessories; perforated side and back walls with key holes (10 x 10) for accessories.

Technische Daten Technical details	Maße Measurements	
Außenmaß (LxBxH) Outside dimens. (LxWxH)	705 x 545 x 960mm	
Volumen Volume	369l	
Innenmaß Schublade Inside dim. of drawers	5x: 578 x 410 x 72, 2x: 578 x 410 x 152mm (LxBxH / LxWxH)	
Schubladenunterteilung Separation of drawers	Flexibel durch Längsteiler Flexible due to separating strips	
Gewicht leer Weight empty	65kg	Art.-Nr. / No. 8155 0020
Verfügbare Module Available module systems	ABS Maxi / MTS / ModuFlex	€ 578,--

Flexi.

Industrial-Line

Extrem stabiler Werkstattwagen "Flexi"; sehr hoch belastbar; Rollen mit 160 mm Durchmesser für leichtgängigen Transport; Jalousieverschluss, zentral abschließbar; 2 Schubladen mit Vollauszug, kugelgelagerte Teleskopschienen, 3 Böden zur Werkzeugaufnahme mit Rollkante; gute Übersichtlichkeit; Seitenwände mit Lochung (10 x 10) für zahlreiches Zubehör; stabiler Griff; abgerundete Kanten als Stoßschutz.

Model "Flexi"; very rugged design; heavy steel construction; high capacity; 2 drawers - running on ball bearings; central cylinder lock system; jalousie; perforated side and back wall with key holes (10 x 10) for accessories; 2 stable and 2 mobile wheels; 160 mm diameter of wheels for easy transport.

Werkstattwagen "Flexi"
Workshop Trolley "Flexi"



Technische Daten Technical details	Maße Measurements	
Außenmaß (LxBxH) Outside dimens. (LxWxH)	800 x 460 x 1.030mm	
Volumen Volume	379l	
Innenmaß Schublade Inside dim. of drawers	2x: 560 x 290 x 40mm (LxBxH / LxWxH)	
Schubladenunterteilung Separation of drawers	Keine / None	
Gewicht leer Weight empty	56kg	Art.-Nr. / No. 8161 0020
Verfügbare Module Available module systems	ModuFlex	€ 558,--



Ideal für industrielle Anwender.
Perfect for industrial users.

Angenehme Arbeitshöhe (103cm).
Comfortable working height.

Leichte Einsehbarkeit.
Good visibility.

Schubladen mit Vollauszug.
Drawers fully extendable.

Komplett abschließbar.
Fully lockable.

Rundum 10x10mm-Lochung für Zubehör.
Panels with 10x10mm-holes on all sides.

Kugelgelagerte Schubladenführungen.
Drawers with ball-bearings.

Sehr beweglich durch 160er Reifen.
Very agile due to 160mm tyres.

Module / Modules

Stellen Sie sich Ihren eigenen Wagen zusammen. Seite kopieren, Wagen und Module ankreuzen und Ihrem Fachhändler geben - oder an MATADOR schicken.

Art.-Nr./No.	X
--------------	----------

Arrange your own workshop trolley. Just copy this double page, mark your trolley and the modules you require and send it to your dealer or to MATADOR.



Multi	Combi	CombiPlus
<input type="checkbox"/>	<input type="checkbox"/>	<input type="checkbox"/>

Passend für / Fits in
Multi. Combi. CombiPlus.



ABS Maxi 185 x 350	ABS Maxi 185 x 350	ABS Maxi 185 x 350
Schubladen-Innenmaß Drawer inside measurements 566 x 415 mm		

ABS Maxi.

Doppelmaulschlüssel
Double Open Ended Spanners

6 x 7, 8 x 9, 10 x 11, 12 x 13,
14 x 15, 16 x 17, 18 x 19,
20 x 22mm

Art.-Nr. / No.	<input checked="" type="checkbox"/>	EUR
0105 5043	900	29,50
8-tlg. / pcs.		

Ringmaulschlüssel, DIN 3113 A
Ring Jaw Wrenches, DIN 3113 A

8, 10, 11, 13, 14, 17, 19, 22mm

Art.-Nr. / No.	<input checked="" type="checkbox"/>	EUR
0185 0042	950	36,50
8-tlg. / pcs.		

Ringratschenschlüssel, VA-Stahl
Ring Ratchet Spanners, stainless

8, 10, 11, 13, 14, 17, 19mm

Art.-Nr. / No.	<input checked="" type="checkbox"/>	EUR
0186 5042	1200	95,--
7-tlg. / pcs.		

Ringmaulschlüssel, DIN 3113 B
Ring Jaw Wrenches, DIN 3113 B

8, 10, 11, 13, 14, 17, 19, 22mm

Art.-Nr. / No.	<input checked="" type="checkbox"/>	EUR
0190 5011	750	43,--
8-tlg. / pcs.		

Doppelringschlüssel, DIN 838
Double Ended Ring Spanners

6 x 7, 8 x 9, 10 x 11, 12 x 13,
14 x 15, 16 x 17, 18 x 19mm

Art.-Nr. / No.	<input checked="" type="checkbox"/>	EUR
0205 5044	1050	43,--
7-tlg. / pcs.		

Gerade Doppelringschlüssel
Flat Double Ended Ring Spanners

8 x 9, 10 x 11, 12 x 13, 14 x 15,
16 x 17, 18 x 19, 20 x 22,
24 x 27mm

Art.-Nr. / No.	<input checked="" type="checkbox"/>	EUR
0220 5001	700	44,--
8-tlg. / pcs.		

Ringratschenschlüssel
Ring Ratchet Spanners

8 x 9, 10 x 11, 12 x 13,
14 x 15, 17 x 19mm

Art.-Nr. / No.	<input checked="" type="checkbox"/>	EUR
0224 5042	800	145,--
5-tlg. / pcs.		

Offene Ringschlüssel
Flare Nut Ring Spanners

8 x 10, 10 x 12, 11 x 13, 14 x 17,
16 x 18, 17 x 19, 19 x 22, 22 x 24mm

Art.-Nr. / No.	<input checked="" type="checkbox"/>	EUR
0251 5001	1200	70,--
8-tlg. / pcs.		

Zangen
Pliers

(500) 185mm
(530) 180mm
(585) 200mm

Art.-Nr. / No.	<input checked="" type="checkbox"/>	EUR
0500 8501	900	49,--
3-tlg. / pcs.		

VDE-Zangen
VDE-Pliers

(500) 180mm
(532) 160mm
(585) 205mm

Art.-Nr. / No.	<input checked="" type="checkbox"/>	EUR
0501 8501	1000	59,--
3-tlg. / pcs.		

Zangen
Pliers

(500) 185mm
(530) 180mm
(556) 240mm

Art.-Nr. / No.	<input checked="" type="checkbox"/>	EUR
0556 5001	1000	46,--
3-tlg. / pcs.		

Sicherungsring-Zangen
Circlip Pliers

(578) A2
(580) A21
(582) J2
(584) J21

Art.-Nr. / No.	<input checked="" type="checkbox"/>	EUR
0578 8402	700	46,--
4-tlg. / pcs.		

Maxi

Passend für / Fits in
Maxi.



ABS Maxi 185 x 350	ABS Maxi 185 x 350	ABS Maxi 185 x 350
Schubladen-Innenmaß Drawer inside measurements 578 x 410 mm		

Schraubendreher
Screwdrivers

(615) 4x75, 5x100, 5.5x125,
6.5x150mm
(655) PH 1+2

Art.-Nr. / No.	⚖️	X	EUR
0615 5501	600		24,--
6-tlg. / pcs.			

VDE-Schraubendreher
VDE-Screwdrivers

(616) 2,5 x 75;
3,5 x 100,
5,5 x 125;
6,5 x 150
(656) PH 1+2

Art.-Nr. / No.	⚖️	X	EUR
0616 5601	650		25,--
6-tlg. / pcs.			

TORX-Schraubendreher
TORX-Screwdrivers

(620)TX 15, TX 20, TX 25,
TX 27, TX 30, TX 40

Art.-Nr. / No.	⚖️	X	EUR
0620 5001	600		31,--
6-tlg. / pcs.			

Werkzeug-Satz
Tool Set

(705) 300g, (714) 150 x 18, 200 x 24,
(717) 120 x 4mm,
(718) Ø 3, 4, 5, 6mm

Art.-Nr. / No.	⚖️	X	EUR
0705 5001	1450		35,--
8-tlg. / pcs.			

1/4"-Steckschlüssel-Garnitur
1/4"-Socket Set

(2061), (2064), (2065), (2066), (2068),
(2073), (2075) 4; 4,5; 5; 5,5; 6; 7; 8; 9;
10; 11; 13mm, (2076) 4; 5,5; 7mm,
(2077) No. 1; 2; 3, (2078) 3; 4; 5; 6; 8,
(440) 1,5-10mm

Art.-Nr. / No.	⚖️	X	EUR
2135 0011	700		105,--
37-tlg. / pcs.			

1/4"-TORX-Garnitur
1/4"-Socket Set TORX

(2061), (2064), (2065), (2066), (2068),
(2073), (2075) 4; 4,5; 5; 5,5; 6; 7; 8; 9;
10; 11; 13mm, (2090) E 4; 5; 6; 7; 8;
10; 11, (2092) TX 8; 10; 15; 20; 25; 27;
30; 40; (440) 1,5-10mm

Art.-Nr. / No.	⚖️	X	EUR
2136 5012	700		110,--
41-tlg. / pcs.			

3/8"-Steckschlüssel-Garnitur
3/8"-Socket Set

19-tlg. / pcs.
(3061), (3064), (3065), (3066), (3068),
(3075) 6; 7; 8; 9; 10; 11; 13; 14; 16;
17; 18; 19; 20; 22mm

Art.-Nr. / No.	⚖️	X	EUR
3115 5002	1600		90,--
3115 5001	1600		

1/2"-Steckschlüssel-Garnitur
1/2"-Socket Set

17-tlg. / pcs.
(4060), (4065), (4066), (4075)
10; 11; 12; 13; 14; 15; 16; 17;
18; 19; 20; 21; 22; 24mm

Art.-Nr. / No.	⚖️	X	EUR
4105 5014	2300		80,--
4105 5011	2300		

1/2"-Schraubendreher-Einsätze
1/2"-Screwdriver Sockets

(4078) 5, 6, 8, 10 x 60mm,
(4079) 6, 8, 10, 12 x 100mm,
(4092) TX 30, 40, 45, 50 x 60mm

Art.-Nr. / No.	⚖️	X	EUR
4078 5001	1150		72,--
12-tlg. / pcs.			

1/2"-TORX-Einsätze
1/2"-Sockets for TORX screws

24-tlg. / pcs.
TX 20, 25, 27, 30, 40, 45, 50, 55, 60;
E 10, 12, 14, 16, 18, 20, 24
+ TX 9 - TX 40 Stiftschlüssel /
Allen Keys

Art.-Nr. / No.	⚖️	X	EUR
4092 5001	1600		110,--
4092 5002	1600		



Leermodul Combi / Multi
Empty Module Combi / Multi

als Zubehör / additionally

185 x 350mm

Art.-Nr. / No.	⚖️	X	EUR
8140 0117	40		6,50

Distanzmodul Combi / Multi
Distance Module Combi / Multi

Combi / Multi 8156 00 95
1x pro Schublade benötigt
Use 1x per drawer

Maxi 8155 00 95
1x pro Schublade benötigt
Use 1x per drawer

Art.-Nr. / No.	⚖️	X	EUR
8156 0095	30		3,50
8155 0095			

Ersatz-Module
Empty modules

Art.-Nr. / No.	Passend für / Suitable for
0190 00 95	105, 185, 186, 190, 220, 224, 251
0205 00 95	200
0500 00 95	500, 501, 556
0578 00 95	578
0615 00 95	615, 616, 620
0705 00 95	705
2135 00 95	2135, 2136
3115 00 95	3115
4078 00 95	4078
4092 00 95	4092
4105 00 95	4105

je / each
EUR
6,50

Pakete / Package Deals

Multi / Combi CombiPlus ABS 83-tlg./pcs.



Art.-Nr. / No.	Multi	EUR
8157 0056	83-tlg. / pcs.	828,--
8157 0076		

Art.-Nr. / No.	Combi	EUR
8156 6056	83-tlg. / pcs.	828,--
8156 6076		

Art.-Nr. / No.	CombiPlus	EUR
8156 6057	83-tlg. / pcs.	898,--
8156 6077		

Ringmaulschlüssel, DIN 3113 B
Ring Jaw Wrenches, DIN 3113 B

8, 10, 11, 13, 14, 17, 19, 22mm

Art.-Nr. / No.	X	EUR
0190 5011	750	43,--
8-tlg. / pcs.		

Zangen
Pliers

(500) 185mm
(530) 180mm
(556) 240mm

Art.-Nr. / No.	X	EUR
0556 5001	1000	46,--
3-tlg. / pcs.		

Schraubendreher
Screwdrivers

(615) 4x75, 5x100, 5.5x125,
6.5x150mm
(655) PH 1+2

Art.-Nr. / No.	X	EUR
0615 5501	600	24,--
6-tlg. / pcs.		

Werkzeug-Satz
Tool Set

(705) 300g, (714) 150 x 18, 200 x 24,
(717) 120 x 4mm,
(718) Ø 3, 4, 5, 6mm

Art.-Nr. / No.	X	EUR
0705 5001	1450	35,--
8-tlg. / pcs.		

1/4"-TORX-Garnitur
1/4"-Socket Set TORX

(2061), (2064), (2065), (2066), (2068),
(2073), (2075) 4; 4.5; 5; 5.5; 6; 7; 8; 9;
10; 11; 13mm, (2090) E 4; 5; 6; 7; 8;
10; 11, (2092) TX 8; 10; 15; 20; 25; 27;
30; 40; (440) 1,5-10mm

Art.-Nr. / No.	X	EUR
2136 5012	700	110,--
41-tlg. / pcs.		

1/2"-Steckschlüssel-Garnitur
1/2"-Socket Set

17-tlg. / pcs.
(4060), (4065), (4066), (4075)
10; 11; 12; 13; 14; 15; 16; 17;
18; 19; 20; 21; 22; 24mm

Art.-Nr. / No.	X	EUR
4105 5014	2300	80,--
4105 5011	2300	

Gratis / free:

EUR

Gratis / free:

3 Leermodule / 3 Trays

Gratis / free:

1 Kleinteilefach / 1 Accessory Tray

Gratis / free:

4 Schubladen-Trennbleche
4 Separation Sheets

Maxi ABS

150-tlg./pcs.

Art.-Nr. / No.	Maxi	EUR
8155 0056	150-tlg. /	1.295,--
8155 0076	pcs.	

inkl. Papierrollenhalter
with paper holder

Gratis / free:



inkl. Papierkorb
with basket

- Besonders viel Stauraum
- Schubladen-Einzelverriegelung
- Angenehme Arbeitshöhe
- Komplett mit riesigem Sortiment an Qualitätswerkzeugen
- Ringsum 10x10-Lochung für umfangreiches Zubehörprogramm

- Extra high capacity
- Each drawer with safety lock
- Comfortable height
- Equipped with large assortment of high quality tools
- Perforated side and back walls with 10x10-holes for accessories

 Ringratschenschlüssel, VA
Ring Ratchet Spanners, stainless



Art.-Nr. / No. 0186 5042

 Doppelringschlüssel, DIN 838
Double Ended Ring Spanners



Art.-Nr. / No. 0205 5044

 Zangen
Pliers



Art.-Nr. / No. 0500 8501

 Sicherungsring-Zangen
Circlip Pliers



Art.-Nr. / No. 0578 8402

 Schraubendreher
Screwdrivers



Art.-Nr. / No. 0615 5501

 TORX-Schraubendreher
TORX-Screwdrivers



Art.-Nr. / No. 0620 5001

 Werkzeug-Satz
Tool Set



Art.-Nr. / No. 0705 5001

 1/4"-Garnitur
1/4"-Socket Set



Art.-Nr. / No. 2135 0011

 3/8"-Steckschlüssel-Garnitur
3/8"-Socket Set



Art.-Nr. / No. 3115 5001/2

 1/2"-Steckschlüssel-Garnitur
1/2"-Socket Set



Art.-Nr. / No. 4105 5014/11

 1/2"-Schraubendreher-Einsätze
1/2"-Screwdriver Sockets



Art.-Nr. / No. 4078 5001

 1/2"-TORX-Einsätze
1/2"-Sockets for TORX screws



Art.-Nr. / No. 4092 5001

inkl. Dosen-
halter
with tin
holder

Module / Modules

Kein Suchen mehr, sehen was fehlt, mehr Ordnung. MTS.

See what is missing. MTS.

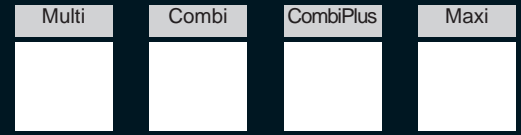

Passend für / Fits in
Multi. Combi. CombiPlus. Maxi.



MTS 185 x 410	MTS 185 x 410	MTS 185 x 410
------------------	------------------	------------------

- Passgenaue Einlagen für jedes Werkzeug in blau / schwarz
- Säurebeständig, einfach abwaschbar
- Perfekte Werkzeugordnung
- Kein Klappern beim Transport - keine durcheinander geschüttelten Werkzeuge
- Recognize immediately where each tool belongs
- Acid-resistant material
- No search
- Dual colour (upper layer in black / lower layer in blue)
- Perfect organization of your tools - less loss
- No rattling during transport - no disordered tools

<p>Ringmaulschlüssel, DIN 3113 B Ring Jaw Wrenches, DIN 3113 B</p> <p>8, 10, 11, 13, 14, 16, 17, 18, 19, 22mm</p> <table border="1"> <thead> <tr> <th>Art.-Nr. / No.</th> <th>⚖️</th> <th>X</th> <th>EUR</th> </tr> </thead> <tbody> <tr> <td>0190 6001</td> <td>1200</td> <td></td> <td>49,--</td> </tr> <tr> <td colspan="4">10-tlg. / pcs.</td> </tr> </tbody> </table>	Art.-Nr. / No.	⚖️	X	EUR	0190 6001	1200		49,--	10-tlg. / pcs.				<p>Zangen Pliers</p> <p>(500) 180mm (530) 180mm (585) 205mm (556) 240mm</p> <table border="1"> <thead> <tr> <th>Art.-Nr. / No.</th> <th>⚖️</th> <th>X</th> <th>EUR</th> </tr> </thead> <tbody> <tr> <td>0556 6001</td> <td>1150</td> <td></td> <td>68,--</td> </tr> <tr> <td colspan="4">4-tlg. / pcs.</td> </tr> </tbody> </table>	Art.-Nr. / No.	⚖️	X	EUR	0556 6001	1150		68,--	4-tlg. / pcs.			
Art.-Nr. / No.	⚖️	X	EUR																						
0190 6001	1200		49,--																						
10-tlg. / pcs.																									
Art.-Nr. / No.	⚖️	X	EUR																						
0556 6001	1150		68,--																						
4-tlg. / pcs.																									
<p>Schraubendreher Screwdrivers</p> <p>(615) 4x75, 5x100, 5.5x125, 6.5x150mm; (655) PH 1, 2, 3; (655) PH 1x25mm (640) 4,0x25mm</p> <table border="1"> <thead> <tr> <th>Art.-Nr. / No.</th> <th>⚖️</th> <th>X</th> <th>EUR</th> </tr> </thead> <tbody> <tr> <td>0615 6001</td> <td>700</td> <td></td> <td>33,--</td> </tr> <tr> <td colspan="4">9-tlg. / pcs.</td> </tr> </tbody> </table>	Art.-Nr. / No.	⚖️	X	EUR	0615 6001	700		33,--	9-tlg. / pcs.				<p>Werkzeug-Satz Tool Set</p> <p>(705) 500g; (714) 150 x 18; 200 x 24; (717) 120 x 4mm; (718) Ø 3, 4, 5, 6mm; (798); (799)</p> <table border="1"> <thead> <tr> <th>Art.-Nr. / No.</th> <th>⚖️</th> <th>X</th> <th>EUR</th> </tr> </thead> <tbody> <tr> <td>0705 6001</td> <td>1700</td> <td></td> <td>39,--</td> </tr> <tr> <td colspan="4">10-tlg. / pcs.</td> </tr> </tbody> </table>	Art.-Nr. / No.	⚖️	X	EUR	0705 6001	1700		39,--	10-tlg. / pcs.			
Art.-Nr. / No.	⚖️	X	EUR																						
0615 6001	700		33,--																						
9-tlg. / pcs.																									
Art.-Nr. / No.	⚖️	X	EUR																						
0705 6001	1700		39,--																						
10-tlg. / pcs.																									
<p>1/2"-Schraubendreher-Einsätze 1/2"-Screwdriver Sockets</p> <p>(4078) 5, 6, 7, 8, 8, 10, 12, 14, 17x60; 5, 6, 7, 8x110mm; (4079) XZN M5, M6, M8, M10x60; M6, 8, 10x100; (4092) TX25, 27, 30, 40, 45, 50, 55, 60x60mm; 45, 55x140mm; 70x110mm</p> <table border="1"> <thead> <tr> <th>Art.-Nr. / No.</th> <th>⚖️</th> <th>X</th> <th>EUR</th> </tr> </thead> <tbody> <tr> <td>4078 6001</td> <td>2950</td> <td></td> <td>168,--</td> </tr> <tr> <td colspan="4">31-tlg. / pcs.</td> </tr> </tbody> </table>	Art.-Nr. / No.	⚖️	X	EUR	4078 6001	2950		168,--	31-tlg. / pcs.				<p>Kfz-Modul Tool set for cars</p> <p>(568); (760); (4078) 5x110, 6x110, 7x100, 8x110mm; (4079) XZN M6x100, M8x100, M10x140, M12x140; (4081) 16, 18, 20,8mm; (4092) TX45x140, TX55x140, TX70x110</p> <table border="1"> <thead> <tr> <th>Art.-Nr. / No.</th> <th>⚖️</th> <th>X</th> <th>EUR</th> </tr> </thead> <tbody> <tr> <td>4081 6001</td> <td>1700</td> <td></td> <td>95,--</td> </tr> <tr> <td colspan="4">16-tlg. / pcs.</td> </tr> </tbody> </table>	Art.-Nr. / No.	⚖️	X	EUR	4081 6001	1700		95,--	16-tlg. / pcs.			
Art.-Nr. / No.	⚖️	X	EUR																						
4078 6001	2950		168,--																						
31-tlg. / pcs.																									
Art.-Nr. / No.	⚖️	X	EUR																						
4081 6001	1700		95,--																						
16-tlg. / pcs.																									
<p>1/4"-TORX-Garnitur 1/4"-Socket Set TORX</p> <p>(2061), (2064), (2065), (2066), (2068), (2073), (2082); (2075) 4; 4,5; 5; 5,5; 6; 7; 8; 9; 10; 11; 13mm; (2076) PH 1-3; (2077) 3-6; 8mm; (2090) E 4-8, 10, 11; (2092) TX 8; 10; 15; 20; 25; 27; 30; 40; (444) 1,5-10mm</p> <table border="1"> <thead> <tr> <th>Art.-Nr. / No.</th> <th>⚖️</th> <th>X</th> <th>EUR</th> </tr> </thead> <tbody> <tr> <td>2135 6001</td> <td>1150</td> <td></td> <td>148,--</td> </tr> <tr> <td colspan="4">52-tlg. / pcs.</td> </tr> </tbody> </table>	Art.-Nr. / No.	⚖️	X	EUR	2135 6001	1150		148,--	52-tlg. / pcs.				<p>1/2"-Steckschlüssel-Garnitur 1/2"-Socket Set</p> <p>22-tlg./pcs. (4061); (4064); (4065) 125mm; (4066) 250mm; (4068); (4075) 10-22, 24, 27, 30, 32mm</p> <table border="1"> <thead> <tr> <th>Art.-Nr. / No.</th> <th>⚖️</th> <th>X</th> <th>EUR</th> </tr> </thead> <tbody> <tr> <td>4105 6001</td> <td>3050</td> <td></td> <td rowspan="2">98,--</td> </tr> <tr> <td>4105 6012</td> <td>3050</td> <td></td> </tr> </tbody> </table>	Art.-Nr. / No.	⚖️	X	EUR	4105 6001	3050		98,--	4105 6012	3050		
Art.-Nr. / No.	⚖️	X	EUR																						
2135 6001	1150		148,--																						
52-tlg. / pcs.																									
Art.-Nr. / No.	⚖️	X	EUR																						
4105 6001	3050		98,--																						
4105 6012	3050																								
<p>1/2"-Impact-Garnitur 1/2"-Socket Set</p> <p>(7056) 125mm; (7058); (7067) 1/2"x3/4"; (7055) kurz / short 13, 17, 19, 22, 24mm; (7055) lang / long 17, 19, 21, 22, 24mm; (7099/1)</p> <table border="1"> <thead> <tr> <th>Art.-Nr. / No.</th> <th>⚖️</th> <th>X</th> <th>EUR</th> </tr> </thead> <tbody> <tr> <td>7055 6001</td> <td>2450</td> <td></td> <td>98,--</td> </tr> <tr> <td colspan="4">19-tlg. / pcs.</td> </tr> </tbody> </table>	Art.-Nr. / No.	⚖️	X	EUR	7055 6001	2450		98,--	19-tlg. / pcs.				<p>3/4"-Impact-Garnitur 3/4"-Socket Set</p> <p>(7067) 3/4" A x 1/2" I (7057); (7065) kurz / short 24, 27, 30, 32, 36mm; (7066) lang / long 17, 19, 24, 27, 30, 32mm; (7099/1)</p> <table border="1"> <thead> <tr> <th>Art.-Nr. / No.</th> <th>⚖️</th> <th>X</th> <th>EUR</th> </tr> </thead> <tbody> <tr> <td>7065 6001</td> <td>5550</td> <td></td> <td>165,--</td> </tr> <tr> <td colspan="4">14-tlg. / pcs.</td> </tr> </tbody> </table>	Art.-Nr. / No.	⚖️	X	EUR	7065 6001	5550		165,--	14-tlg. / pcs.			
Art.-Nr. / No.	⚖️	X	EUR																						
7055 6001	2450		98,--																						
19-tlg. / pcs.																									
Art.-Nr. / No.	⚖️	X	EUR																						
7065 6001	5550		165,--																						
14-tlg. / pcs.																									

- Doppelmaulschlüssel / Double Open Ended Spanners (100) DIN 3110, 6x7 - 21x23mm
- Ring-Maulschlüssel gekröpft/ Combination Spanners offset (190) DIN 3113 B, 6 - 22mm
- Doppel-Ringschlüssel DIN / Double Ended Ring Spanners (200) DIN 838, 6x7 - 21x23mm

Art.-Nr. / No.		X	EUR
0195 6001	1900		158,-
35-tlg. / pcs.			

Schlüssel-Modul, groß

Large Module of Wrenches

1/1 - 555 x 410mm

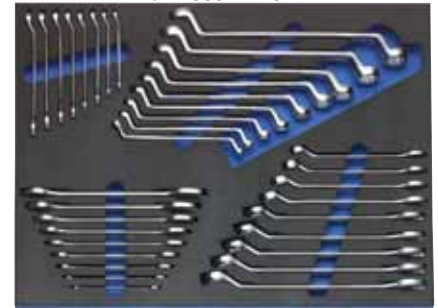

- Doppelmaulschlüssel / Double Open Ended Spanners DIN 3110 24X27, 25X28, 30X32mm
- Ring-Maulschlüssel / Combination Spanners DIN 3113 A 24, 27, 30, 32mm (185)
- Ringschlüssel / Double Ended Ring Spanners DIN 838 24X27, 25X28, 30X32mm (200)
- Schraubendreher Schlitz / Screwdrivers slotted 1,2x8,0mm, 1,6x10,00mm, 2,0x12,00mm (600)
- Schraubendreher / Screwdrivers for cross slot screws Philips Recess PH 2, 3, 4 (650)
- Rückschlagfreier Schonhammer / Non rebound Sledge hammer 40mm / 750g (702)
- Schlosserhammer / Locksmith Hammer 1000g
- Reifenmontierhebel / Tyre Lever 500mm

Art.-Nr. / No.		X	EUR
0600 6001	2400		178,-
19-tlg. / pcs.			

Nutzfahrzeug-Satz, groß

Tool Assortment for trucks

1/1 - 555 x 410mm



- 1/2"-Drehmomentschlüssel / Torque Wrench, 40-200Nm (6176)
- Fühlerlehren 20 Blatt / Feeler Gauges 20 blades 0,05-1,0mm (760)
- Gewindeschablone / Screw pitch gauge 0,25-6mm / 4-62 W (764)
- Stahlbandmaß / Steel rule (798)
- Stahlmaßstab starr / Steel rule nonflexible (798)
- Haarlineal / Knife Edge Straight (798)
- Taschenmeßschieber / Pocket Vernier Caliper
- Wasserwaage / Spirit Level 400mm
- Werkstattwinkel / Workshop Square 200x139(28x6)mm (798)
- Hartmetall-Reißnadel / Hard Metal Marking Tool

Art.-Nr. / No.		X	EUR
0798 6001	2200		238,-
11-tlg. / pcs.			

Messwerkzeug-Satz, groß

Set of Measuring Tools

1/1 - 555 x 410mm



MTS-Leermodule (1/1-Schublade)

MTS Empty Modules (1/1 of drawer)

Art.-Nr. / No.	Passend für / Suitable for	je / each EUR
0195 60 95	100, 185, 200 (1/1)	35,00
0600 60 95	600 (1/1)	
0798 60 95	798 (1/1)	

MTS-Leermodule (1/3-Schublade)

MTS Empty Modules (1/3 of drawer)

Art.-Nr. / No.	Passend für / Suitable for	je / each EUR
0190 60 95	190 (1/3)	16,50
0556 60 95	556 (1/3)	
0615 60 95	615 (1/3)	
0705 60 95	705 (1/3)	
2135 60 95	2135 (1/3)	
4105 60 95	4105 (1/3)	
4078 60 95	4078 (1/3)	
4081 60 95	4081 (1/3)	
7055 60 95	7055 (1/3)	
7065 60 95	7065 (1/3)	

MATADOR Tools
System. MTS.

Pakete / Package Deals

Combi CombiPlus MTS 107-tlg./pcs.

Gratis / free:



Ringmaulschlüssel, DIN 3113 B
Ring Jaw Wrenches, DIN 3113 B



8, 10, 11, 13, 14, 16, 17, 18,
19, 22mm

Art.-Nr. / No.	⚖️	X	EUR
0190 6001	1200		49,--
10-tlg. / pcs.			

Zangen
Pliers



(500) 185mm
(530) 180mm
(585) 200mm
(556) 240mm

Art.-Nr. / No.	⚖️	X	EUR
0556 6001	1150		68,--
4-tlg. / pcs.			

Schraubendreher
Screwdrivers



(615) 4x75, 5x100, 5.5x125,
6.5x150mm; (655) PH 1, 2, 3;
(655) PH 1x25mm
(640) 4,0x25mm

Art.-Nr. / No.	⚖️	X	EUR
0615 6001	700		33,--
9-tlg. / pcs.			

Werkzeug-Satz
Tool Set



(705) 500g; (714) 150 x 18; 200 x 24;
(717) 129 x 4mm;
(718) Ø 3, 4, 5, 6mm; (798); (799)

Art.-Nr. / No.	⚖️	X	EUR
0705 6001	1700		39,--
10-tlg. / pcs.			

1/4"-TORX-Garnitur
1/4"-Socket Set TORX



(2061), (2064), (2065), (2066), (2068),
(2073), (2082); (2075) 4; 4,5; 5; 5,5; 6;
7; 8; 9; 10; 11; 13mm, (2076) PH 1-3;
(2077), 3-6; 8mm; (2078) E 4-8, 10,
11; (2092) TX 8; 10; 15; 20; 25; 27; 30;
40; (444) 1,5-10mm

Art.-Nr. / No.	⚖️	X	EUR
2135 6001	1150		148,--
52-tlg. / pcs.			

1/2"-Steckschlüssel-Garnitur
1/2"-Socket Set



22-tlg./pcs.
(4061); (4064); (4065) 125mm; (4066)
250mm; (4068); (4075)
10-22, 24, 27, 30,32mm

Art.-Nr. / No.	⚖️	X	EUR
4105 6001	3050		98,--
4105 6012	3050		

Combi



Mit 2 seitlichen Schub-
laden für Kleinteile

Herausnehmbare
Seitenfächer

With 2 side compart-
ments for accessories

Removeable
side trays

Art.-Nr. / No.	Combi	EUR
8156 0680	107-tlg. / pcs.	918,--
8156 0685		

CombiPlus



Zusätzlich mit
- Einzelverriegelung der Schubladen
- Seiten-Stoß-Schutz
- Zweigeteilte Arbeitsplatte

Additionally with
- Individually lockable drawers
- Side protection
- New worktop

Art.-Nr. / No.	CombiPlus	EUR
8156 0681	107-tlg. / pcs.	988,--
8156 0686		

Combi CombiPlus MTS 167-tlg./pcs.

Gratis / free:



Werkstatwagen
Trolleys

Schraubendreher / Screwdrivers



Art.-Nr. / No. 0615 6001

Zangen / Pliers



Art.-Nr. / No. 0556 6001

Kfz-Modul / Tool Assortment for vehicles



Art.-Nr. / No. 4081 6001

Werkzeug-Satz / Tool Set



Art.-Nr. / No. 0705 6001

1/4"-TORX-Garnitur / 1/4"-Socket Set TORX



Art.-Nr. / No. 2135 6001

1/2"-Steckschlüssel-Garnitur / 1/2"-Socket Set



Art.-Nr. / No. 4105 6001/12

Schlüssel-Modul / Module of Wrenches

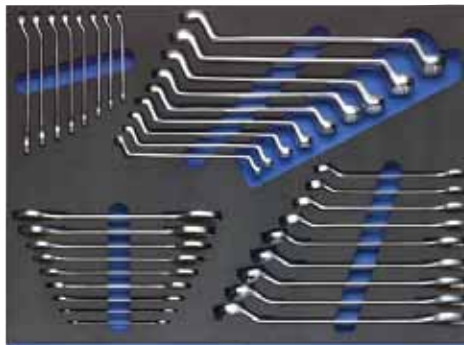

Art.-Nr. / No. 0195 6001

Nutzfahrzeug-Satz / Tool Assortment for trucks



Art.-Nr. / No. 0600 6001



Combi

- Unser Renner-Satz für den Nutzfahrzeugbereich / Top Seller
- Schlüssel bis 30x32mm / Wrenches up to 30x32mm
- Alle wesentlichen TORX- und XZN-Einsätze / All important TORX- and XZN-Sockets
- Holzheft-Schraubendreher mit Schlagkappe / Screwdrivers with wooden handle, shock resistant
- Schlosserhammer 1000g / Locksmith Hammer 1000g

Art.-Nr. / No.	Combi	EUR
8156 0700	167-tlg. / pcs.	1.248,-
8156 0705		



CombiPlus

- Unser Renner-Satz für den Nutzfahrzeugbereich / Top Seller
- Schlüssel bis 30x32mm / Wrenches up to 30x32mm
- Alle wesentlichen TORX- und XZN-Einsätze / All important TORX- and XZN-Sockets
- Holzheft-Schraubendreher mit Schlagkappe / Screwdrivers with wooden handle, shock resistant
- Schlosserhammer 1000g / Locksmith Hammer 1000g

Art.-Nr. / No.	CombiPlus	EUR
8156 0701	167-tlg. / pcs.	1.298,-
8156 0706		



ModuFlex.

Nur für Kreative.
Flexibler geht`s nicht.
For creative people.
High end flexibility.

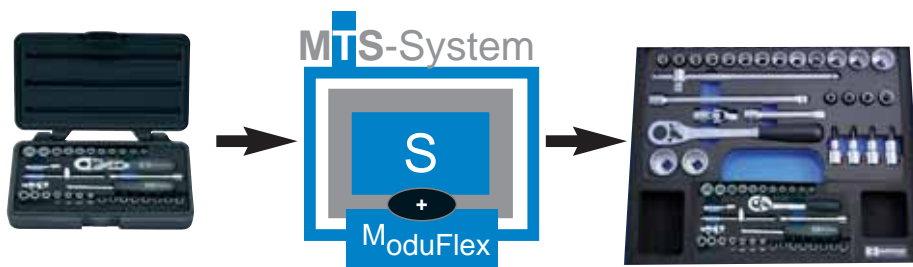

- ModuFlex sind
- 2-farbige MTS-Einlagen
 - in 3 Basisgrößen (S-M-L), die
 - vollkommen flexibel
 - in bestehende Werkstattwagen, in Werkbänke, in Kunststoffkästen usw. passen und die gleichzeitig
 - für dezentrale Arbeiten (z.B. im Fahrerhaus, im Motorenraum, an der Maschine usw.) entnommen werden können.

Immer dann, wenn der gesamte Werkstattwagen nicht direkt an den Einsatzort geschoben werden kann oder man nur einzelne Werkzeuge benötigt, ist ModuFlex ein wertvoller Helfer.

Ideal zum Zusammenstellen "Ihres" Werkstattwagens.

- ModuFlex are
- 2-coloured MTS-modules,
 - available in 3 basic sizes (S-M-L), which are
 - perfectly flexible and
 - fit into common workshop trolleys and work benches, in plastic boxes etc. and
 - can be used easily for all job missions outside (e.g. work in driving cabs, engine areas).

Whenever the entire workshop trolley cannot be moved directly to the place of work or if you need only some single tools, ModuFlex is the ideal help.

Select your own assortment of tools.

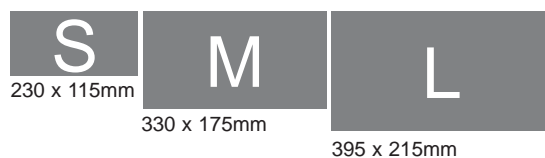

Alle Garnituren mit dem "ModuFlex"-Zeichen passen mit jeweiligem Rahmen in die Werkstattwagen.
All assortments with the "ModuFlex"-sign fit into our trolleys. Just select the right frame.



ModuFlex-Rahmen / Empty Module



Beispielfelder / Empty notches

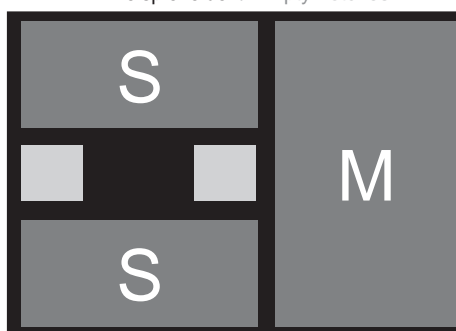

Beispiel / Example



Wählen Sie zunächst einen Rahmen aus.
First select a frame.



Quadro

Schubladen-Innenmaß
Drawer inside measurements
442 x 350mm

Art.-Nr. / No.	<input type="checkbox"/>	X	EUR
8162 6098	SSM		15,-
8162 6099	SL		15,-

Quadro ModuFlex S-S-M
Quadro ModuFlex S-S-M

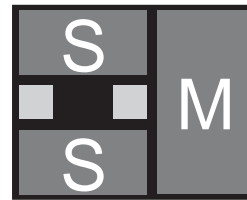

Leermodul für 2xS und 1xM-Aufnahme + 2 Leerfächer
Empty Module with 2xS and 1xM-notches + 2 compartments

Quadro ModuFlex S-L
Quadro ModuFlex S-L

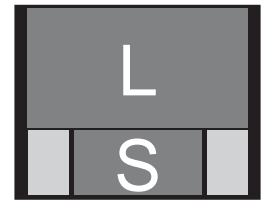

Leermodul für 1xS und 1xL-Aufnahme + 2 Leerfächer
Empty Module with 1xS and 1xL-notches + 2 compartments



Servant

Schubladen-Innenmaß
Drawer inside measurements
495 x 335mm

Art.-Nr. / No.	<input type="checkbox"/>	X	EUR
8158 6098	MSS		15,-
8158 6099	SSL		8,-

Servant ModuFlex M-S-S
Servant ModuFlex M-S-S

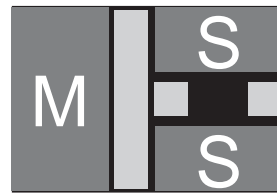

Leermodul für 2xS und 1xM-Aufnahme + 3 Leerfächer
Empty Module with 2xS and 1xM-notches + 3 compartments

Servant ModuFlex S-S-L
Servant ModuFlex S-S-L



3 Distanzblöcke zur Fixierung von 2xS und 1xL-Modulen
3 Distance modules for fixing 2xS and 1xL modules



Combi CombiPlus

Schubladen-Innenmaß
Drawer inside measurements
566 x 415mm

Art.-Nr. / No.	<input type="checkbox"/>	X	EUR
8156 6098	LSSS		19,-
8156 6099	MSSS		19,-

Combi ModuFlex L-S-S-S
Combi ModuFlex L-S-S-S

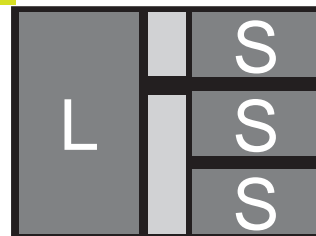

Leermodul für 3xS und 1xL-Aufnahme + 2 Leerfächer
Empty Module with 3xS and 1xL-notches + 2 compartments

Combi ModuFlex M-S-S-S
Combi ModuFlex M-S-S-S

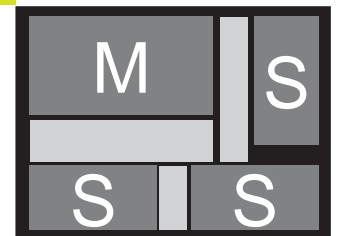

Leermodul für 3xS und 1xM-Aufnahme + 3 Leerfächer
Empty Module with 3xS and 1xM-notches + 3 compartments



Flexi

Schubladen-Innenmaß
Drawer inside measurements
560 x 290mm

Art.-Nr. / No.	<input type="checkbox"/>	X	EUR
8161 6098	LS		15,-

Flexi ModuFlex S-L
Flexi ModuFlex S-L



Leermodul für 1xS und 1xL-Aufnahme + 1 Leerfach
Empty Module with 1xS and 1xL-notches + 1 compartment

Notizen / Notes



Stellen Sie sich "Ihr"
Werkzeugsystem zusammen.
Arrange your own
tools system.

Mehr Details in den jeweiligen Kapiteln / For more details please refer to the particular chapter.

1/4"-Garnitur TORX
1/4"-Socket Set TORX

	2061		4; 4,5; 5;5,5;6-11;13mm
	115mm		E 4-8;10;11
	50,100		TX 8,10,15,20,25,27,30,40
	2068	32-tlg. / pcs.	

Art.-Nr. / No.		SML	EUR
2136 6001	36'	S	85,--
2136 6002	72'	S	

1/4"-Garnitur TORX Gelenkknarre
1/4"-Socket Set TORX

	2063		4; 4,5; 5;5,5;6-11;13mm
	115mm		E 4-8;10;11
	50,100		TX 8,10,15,20,25,27,30,40
	2068	Mit Gelenkknarre, feinverzahnt With flexible ratchet, 72T	

Art.-Nr. / No.		SML	EUR
2136 6003	700	S	88,--
32-tlg. / pcs.			

1/4"-3/8"-1/2" Außen-TORX
1/4"-3/8"-1/2" Outside TORX

1/4"		E 4, 5, 6
3/8"		E 8; 10; 12
1/2"		E 14, 18, 20

Art.-Nr. / No.		SML	EUR
4090 0041	300	S	39,--
9-tlg. / pcs.			

1/4"-3/8"-1/2" Innen-TORX
1/4"-3/8"-1/2" Inside TORX

1/4"		TX 8, 10, 15
3/8"		TX 20, 25, 30
1/2"		TX 40, 50, 55, 60

Art.-Nr. / No.		SML	EUR
4092 0042	350	S	48,--
10-tlg. / pcs.			

1/4"-3/8"-1/2" Adapter-Satz
1/4"-3/8"-1/2" Adapter Set

	1/4"		1/4"		1/4"
	3/8"		1/4", 1/2"		1/4", 5/16"
	1/2"		3/8"		1/4", 5/16", 1/2"

Art.-Nr. / No.		SML	EUR
2082 6001	350	S	39,--
10-tlg. / pcs.			

3/8"-Glühkerzen-Satz
3/8"-Glow Plug Socket Set

	3/8"		8, 9, 10, 12mm
	3/8"		9mm geschlitzt / slotted

Für / For Common Rail-Diesel

Art.-Nr. / No.		SML	EUR
3096 6010	300	S	115,--
5-tlg. / pcs.			

3/8"-Schraubenausdreher-Satz
3/8"-Twist Socket Set

	3/8"		10, 11, 12, 13, 14, 15, 16, 17, 19mm + Bolzen / Pin
--	------	--	---

Art.-Nr. / No.		SML	EUR
0773 6001	500	S	145,--
10-tlg. / pcs.			

Elektroniker-Satz
Set for electricians

	Mini		5x5; 5,5x5,5; 6x6 - 11x11mm
	Bits PH1-4		1,0x50; 2,0x50mm
	Bits PZ1-4		P00, P1
			3-6mm
			TX 10, 15, 20, 25, 27, 30, 40

Art.-Nr. / No.		SML	EUR
0150 6001	450	S	78,--
44-tlg. / pcs.			

Satz Umsteckschraubendreher
Set of revers. blade screwdrivers

		PH 1 - 4,0x0,8mm; PH 2 - PH 3
		PZ 1 - 5,0x0,8; PZ 2 - 6,0x1,0mm
		PZ 3 - 7,0x1,2mm
		TX 10-15, 20-25, 30-40; 3-4; 5-6mm

Art.-Nr. / No.		SML	EUR
0672 6001	450	S	39,--
11-tlg. / pcs.			

Satz Elektroniker-Schraubendreher
Set of Precision Screwdrivers

		0,25x1,0; 0,4x2,0; 0,5x3,0
		PH00; PH 0; PH 1

Art.-Nr. / No.		SML	EUR
0665 6001	220	S	21,--
6-tlg. / pcs.			

Satz Elektroniker-Schraubendreher
Set of Precision Screwdrivers

		TX 5, 6, 7, 8, 10, 15
--	--	-----------------------

Art.-Nr. / No.		SML	EUR
0665 6002	220	S	23,--
6-tlg. / pcs.			

Spezial-Kfz-Bitsortiment TORX
Special Assortment of Bits TORX

	Mini	Bitse in 25 und 100mm Bits in 25 and 100mm	
		1/4" - 1/4"; 3/8" - 1/4"; 3/8" - 5/16"; 1/2" - 5/16"	
		1/4: TX 6, 7, 8, 9, 10, 15, 20 5/16": TX 25, 27, 30, 40, 45, 50, 55	

Art.-Nr. / No.		SML	EUR
7052 6001	350	S	69,--
35-tlg. / pcs.			

1/4"-3/8"-5-Stern / XZN / RIBE-Bits
1/4"-3/8" 5-Star / XZN / RIBE-Bits



	Mini-3061	Bitze in 25 und 100mm Bits in 25 and 100mm
		1/4" - 1/4"; 3/8" - 5/16"
		1/4": TX 9, 15, 25, 30 1/4": TX 10, 15, 20, 25, 27, 30, 40 1/4; 5/16": M4, 5, 6, 8, 10, 12, 14 5/16": M 8, 10, 12, 14, 16 (100mm)

Art.-Nr. / No.	SML	EUR
7052 6002	350 S	79,-
27-tlg. / pcs.		

3/8"-Garnitur, 22-tlg.
3/8"-Socket Set, 22-pcs.



	3061	6-22mm
	200	
	125, 250mm	
	3068	

Art.-Nr. / No.	SML	EUR
3115 6002	M	90,-
3115 6001		

3/8"-Garnitur, 31-tlg.
3/8"-Socket Set, 31-pcs.



	3061	6-19; 21, 22mm
	300	4, 5, 6x60mm; 8x75mm
	75, 125, 250mm	PH 1, 2, 3
	3068	7, 8, 9, 10x60mm

Art.-Nr. / No.	SML	EUR
3125 0002	M	118,-
3125 0001		

1/2"-Umschaltknarrensatz "3in1"
1/2"-Ratchet Set "3in1"



	4061	220mm; 360mm; 570mm
	1/2"	3/8", 3/4"
	4068	

Art.-Nr. / No.	SML	EUR
4061 6020	700 M	75,-
8-tlg. / pcs.		

1/2"-Kfz-Garnitur, 25-tlg.
1/2"-Socket Set, 25-pcs.



	4061	10-24, 27, 30, 32mm
	300mm	16; 20,8mm
	125, 250mm	
	4068	

Art.-Nr. / No.	SML	EUR
4114 6001	L	95,-
4114 6002		

1/2"-Kfz-Garnitur, 25-tlg.
1/2"-Socket Set, 25-pcs.



	4061	10-24, 27, 30, 32mm
	300mm	16; 20,8mm
	125, 250mm	
	4068	Mit feinverzahnter Knarre / With 72-T ratchet

Art.-Nr. / No.	SML	EUR
4114 6003	L	98,-
4114 6004		

1/2"-Garnitur TORX, 44-tlg.
1/2"-Socket Set TORX, 44-pcs.



	4061	10-24, 27, 30, 32mm
	300mm	5, 6, 7, 8, 10, 12, 14x60mm
	125, 250mm	PH 1-4; 0,6; 0,8; 1,2; 1,6
	4068	TX 20, 25, 27, 30, 40

Art.-Nr. / No.	SML	EUR
4140 0001	L	165,-
4140 0002		

1/2"-Garnitur TORX, 41-tlg. 72-Z
1/2"-Socket Set TORX, 41-pcs.



	4061	10-24, 27, 30, 32mm
	300mm	5, 6, 7, 8, 10, 12, 14x60mm
	125, 250mm	PH 1-4; 0,6; 0,8; 1,2; 1,6
	4068	TX 20, 25, 27, 30, 40

Art.-Nr. / No.	SML	EUR
4140 0003	L	168,-
4140 0004		

3/8"-Bremskolbenrückstellsatz
3/8"-Brake Caliper Rewind Tool Kit



Universal-Satz zum Wechseln der Bremsbeläge,
mit 2 Spindeln und 3/8"-Knarrenadapter
Universal Set for servicing and replacement of worn
brake pads, with 2 spindles and 3/8"-ratchet adapter

Art.-Nr. / No.	SML	EUR
0570 3002	950 L	98,-
18-tlg. / pcs.		

Universal Entriegelungssatz PKW
Standard Extraction Tools Set



Die gängigsten Kabelentriegler für PKW
Set of main extraction tools for cars

Art.-Nr. / No.	SML	EUR
0800 0001	600 L	248,-
10-tlg. / pcs.		

Universal Entriegelungssatz NFZ
Standard Extraction Tools Set



Die gängigsten Kabelentriegler für NFZ
Set of main extraction tools for trucks and
commercial vehicles

Art.-Nr. / No.	SML	EUR
0800 0002	600 L	268,-
10-tlg. / pcs.		

10-tlg. Entriegelungssatz VW
Extraction Tools Set VW, 10-pcs.



Die gängigsten Kabelentriegler für VW / Audi /
SEAT / Skoda
Set of main extraction tools for VW / Audi /
SEAT / Skoda

Art.-Nr. / No.	SML	EUR
0800 0003	600 L	268,-
10-tlg. / pcs.		

20-tlg. Entriegelungssatz VW
Extraction Tools Set VW, 20-pcs.



Die wichtigsten Kabelentriegler für VW / Audi /
SEAT / Skoda
Set of main extraction tools for VW / Audi /
SEAT / Skoda
Golf 1-5, Jetta, Polo 3, Audi A3, A4, A6, Audi 80, Audi
200, Scirocco, Passat, Passat VR6, Lupo, Sharan,
LT2, T3, T5, Corrado

Art.-Nr. / No.	SML	EUR
0800 6004	850 L	485,-
20-tlg. / pcs.		

10-tlg. Entriegelungssatz Mercedes
Extraction Tools Set MB, 10-pcs.



Die wichtigsten Kabelentriegler für Mercedes Benz
Set of main extraction tools for Mercedes Benz

Art.-Nr. / No.	SML	EUR
0800 6005	600 L	278,-
10-tlg. / pcs.		

20-tlg. Entriegelungssatz Mercedes
Extraction Tools Set MB, 20-pcs.



Die wichtigsten Kabelentriegler für Mercedes Benz
Set of main extraction tools for Mercedes Benz

Art.-Nr. / No.	SML	EUR
0800 6006	850 L	528,-
20-tlg. / pcs.		

Notizen / Notes

Zubehör / Accessories

Compact

Quadro

Servant

Multi

Combi

CombiPlus

Maxi

Flexi

Ersatzschlösser

Spare Locks



Mit 2 Ersatzschlüsseln
With 2 spare keys

Art.-Nr. / No.		EUR
8140 0012	Compact	15,--
8140 0022	Multi	15,--
8140 0002	Combi	15,--

Quadro / Servant / Maxi auf Anfrage / on request

Ersatz-Universalschlüssel

Spare Universal Key



Nach Schlüssel-Nr., nicht direkt ab Lager
According to key number, not ex stock

Art.-Nr. / No.		EUR
8140 0090	Compact	7,50
8140 0091	Multi	7,50
8140 0092	Combi / Flexi	7,50

Quadro / Servant / Maxi auf Anfrage / on request

Ersatzrad ohne Bremse

Spare Wheel without brake



Art.-Nr. / No.		EUR
8140 0013	Compact	12,50
8140 0003	Multi / Combi	12,50
8140 0073	Flexi	12,50

Quadro / Servant / Maxi auf Anfrage / on request

Ersatzrad mit Bremse

Spare Wheel with brake



Art.-Nr. / No.		EUR
8140 0014	Compact	14,50
8140 0004	Multi / Combi	14,50
8140 0074	Flexi	14,50

Quadro / Servant / Maxi auf Anfrage / on request

Ersatz-Achse mit 2 Rädern

Spare Axles with 2 Wheels



Art.-Nr. / No.		EUR
8140 0015	Compact	19,--
8140 0005	Multi / Combi	19,--

Quadro / Servant / Maxi / Flexi auf Anfrage / on request

Ersatz-Gummimatte

Spare Rubber Matt

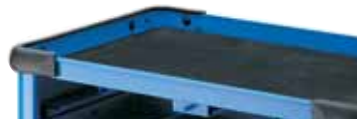

Art.-Nr. / No.		EUR
8140 0011	Compact	7,50
8140 0001	Multi / Combi	7,50

Gummimatte für Schublade

Rubber Matt for Drawer



Art.-Nr. / No.		EUR
8140 0093	Compact	7,50
8140 0094	Multi / Combi	7,50
8140 0095	Quadro	7,50
8140 0096	Servant	7,50
8140 0097	Maxi	7,50

Ersatzgriff aus Kunststoff

Plastic Spare Handle with screws



Art.-Nr. / No.		EUR
8140 0006	Multi / Combi	6,50

Ersatzgriff aus Kunststoff

Plastic Spare Handle with screws



Art.-Nr. / No.		EUR
8140 0050	Quadro / Maxi	12,--

Ersatz-Kantenschutz

Spare Edge Protector



Art.-Nr. / No.		EUR
8140 0007	Multi / Combi	6,--

Ersatz-Kantenschutz CombiPlus

Spare Edge Protector CombiPlus



Art.-Nr. / No.		EUR
8140 0087	CombiPlus	6,--

Ersatz-Schubladenschiene (2x)

Spare Drawer slide (2x)



Art.-Nr. / No.		EUR
8140 0010	Compact	18,--
8140 0020	Multi	18,--
8140 0021	Servant	18,--
8140 0051	Quadro	18,--
8140 0061	Maxi	18,--

Ersatz-Schubladenschiene (2x)

Spare Drawer slide (2x)



Art.-Nr. / No.		EUR
8140 0071	Compact	18,--
8140 0019	Combi Kugelgelagert Ball bearing type	18,--
8140 0009	Combi Teleskop Telescope type	18,--

Notizen / Notes

Kabelbox
Cable Drum



4 VDE-geprüfte Schutzkontakt-Steckdosen, eingebauter Überlastungsschutz
Cable Drum, 4 VDE-tested and shock proof plugs, export version on request

Art.-Nr. / No.	EUR
8141 0001 10m	22,-

Handleuchte "Profi-Lux"
Handlamp "Profi-Lux"



330 Lumen, 8W / 230 V AC, Kabellänge 5m, austauschbare Leuchtstoffröhre
330 Lumen, 8 W / 230 V AC, cable length 5m, tube changeable, export version on request

Art.-Nr. / No.	EUR
8142 0001 525mm	28,-
8142 0010 Ersatzleuchte / Spare lamp	4,-
8142 0011 Ersatzgehäuse / Spare cover	4,50

Trennbleche für Seitenfächer
Separation Sheets for side panels



4-tlg. / pcs.

Art.-Nr. / No.	EUR
8140 0111 Multi / Combi	12,80

ABS Maxi-Ablagemodul
ABS Maxi Empty Tray



185 x 350mm

Art.-Nr. / No.	EUR
8140 0117 Multi / Combi	6,50

Kleinteilefach für Kunststoffgriff
Accessory Tray for small parts



Art.-Nr. / No.	EUR
8140 0008 Multi / Combi	8,75

Kunststoffhaken kurz
Plastic Hook short



Passend für Paneele 8140 0116 und Multi
Suitable for tool panel 8140 0116 and Multi

Art.-Nr. / No.	EUR
8140 0120 20 tlg. / pcs.	0,20

Kunststoffhaken lang
Plastic Hook long



Passend für Paneele 8140 0116 und Multi
Suitable for tool panel 8140 0116 and Multi

Art.-Nr. / No.	EUR
8140 0121 20 tlg. / pcs.	0,30

Kunststoffhaken rund
Plastic Hook round



Passend für Paneele 8140 0116 und Multi
Suitable for tool panel 8140 0116 and Multi

Art.-Nr. / No.	EUR
8140 0122 20 tlg. / pcs.	0,25

Kunststoffhaken für Zangen etc.
Plastic Hook for pliers etc.



Passend für Paneele 8140 0116 und Multi
Suitable for tool panel 8140 0116 and Multi

Art.-Nr. / No.	EUR
8140 0123 20 tlg. / pcs.	0,40

Kunststoffkasten für Kleinteile
Plastic Box for small parts



Passend für Paneele 8140 0116 und Multi
Suitable for tool panel 8140 0116 and Multi

Art.-Nr. / No.	EUR
8140 0125 1 tlg. / pcs.	1,50

Kunststoffkasten für Kleinteile
Plastic Box for small parts



Passend für Paneele 8140 0116 und Multi
Suitable for tool panel 8140 0116 and Multi

Art.-Nr. / No.	EUR
8140 0126 1 tlg. / pcs.	1,50

Trennbleche für Schubladen
Separation Sheets for trays



4-tlg. / pcs.

Art.-Nr. / No.	EUR
8140 0112 Multi / Combi	12,-
8140 0212 Quadro	12,-
8140 0312 Maxi	12,-

Trennbleche mit Rasterung
Separation Sheets for trays



6-tlg. / pcs.

Art.-Nr. / No.	EUR
8140 0113 Multi / Combi	15,50
8140 0213 Quadro	15,50
8140 0313 Maxi	15,50

Blechschaalen mit Trennscheiben
Sheet Trays with dividers



6-tlg. / pcs.

Art.-Nr. / No.	EUR
8140 0114 Multi / Combi	48,-

Blechschaalen mit Trennscheiben
Sheet Trays with dividers



3-tlg. / pcs.

Art.-Nr. / No.	EUR
8140 0115 Multi / Combi	42,-

Werkzeugpaneele 780 x 460mm
Perforated Panel 780 x 460mm

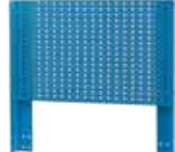

Montage durch Anbringung einer Aussparung am Griff und am Kantenschutz
Mounting is possible by modifying the handle and the edge protection

Art.-Nr. / No.	EUR
8140 0116 Combi	24,-

Zubehör / Accessories

Quadro

Maxi

Flexi

10x10mm
Standard-
lochung

Einfachhaken, pulverbeschichtet
Single Hook, powder coated



Zum Verschrauben in 10x10mm-Lochung, sehr stabil
To bolt together with panel, very solid

Art.-Nr. / No.		EUR
8141 0100	50mm	0,95
8141 0101	150mm	1,25

Doppelhaken, pulverbeschichtet
Double Hook, powder coated



Zum Verschrauben in 10x10mm-Lochung, sehr stabil
To bolt together with panel, very solid

Art.-Nr. / No.		EUR
8141 0110	50mm	1,85
8141 0111	150mm	2,20

Zangenhalter, viereckig
Hook for pliers, square



Zum Verschrauben in 10x10mm-Lochung, sehr stabil
To bolt together with panel, very solid

Art.-Nr. / No.		EUR
8141 0115	55mm	2,--

Rundhalter, pulverbeschichtet
Round Hook, powder coated



Zum Verschrauben in 10x10mm-Lochung, sehr stabil
To bolt together with panel, very solid

Art.-Nr. / No.		EUR
8141 0120	65mm / 25mm	2,40

Kleinteileablage
Accessory Tray



Zum Verschrauben in 10x10mm-Lochung, sehr stabil
To bolt together with panel, very solid

Art.-Nr. / No.		EUR
8141 0130	150 mm / 55mm	8,40

Schlüsselhalter 8-fach
Holder for spanners, 8-pcs.



Zum Verschrauben in 10x10mm-Lochung, sehr stabil
To bolt together with panel, very solid

Art.-Nr. / No.		EUR
8141 0140		6,90

Schraubendreherhalter 6-fach
Holder for screwdrivers, 6-pcs.



Zum Verschrauben in 10x10mm-Lochung, sehr stabil
To bolt together with panel, very solid

Art.-Nr. / No.		EUR
8141 0150		5,20

Bohrerhalter, 14-fach
Holder for drills, 14-pcs.



Zum Verschrauben in 10x10mm-Lochung, sehr stabil
To bolt together with panel, very solid

Art.-Nr. / No.		EUR
8141 0160		5,45

Lagersichtkastenhalter, 5-fach
Storage box holder, 5-pcs



Zum Verschrauben in 10x10mm-Lochung, sehr stabil
To bolt together with panel, very solid

Art.-Nr. / No.		EUR
8141 0170	Für Größe 5 / for size 5	7,60

Steckschlüsselhalter, 12-fach
Holder for sockets, 12-pcs.



Zum Verschrauben in 10x10mm-Lochung, sehr stabil
To bolt together with panel, very solid

Art.-Nr. / No.		EUR
8141 0180		9,60

Kabelhalter, pulverbeschichtet
Holder for cables, powder coated



Zum Verschrauben in 10x10mm-Lochung, sehr stabil
To bolt together with panel, very solid

Art.-Nr. / No.		EUR
8141 0190	150mm	3,20

Papierrollenhalter
Paper Roll holder



Zum Verschrauben in 10x10mm-Lochung, sehr stabil
To bolt together with panel, very solid

Art.-Nr. / No.		EUR
8141 0200		12,--

Metallpapierkorb
Metal basket



Zum Verschrauben in 10x10mm-Lochung, sehr stabil
To bolt together with panel, very solid

Art.-Nr. / No.		EUR
8141 0210		15,--

Dosenhalter, 3-fach
Tin Holder, 3 tins

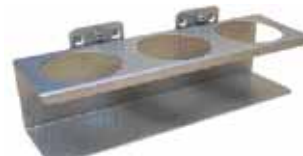

Zum Verschrauben in 10x10mm-Lochung, sehr stabil
To bolt together with panel, very solid









Art.-Nr. / No.		EUR
8141 0220	300 x 70mm	10,50

Halter für Zeichnungen
Holder for drawings



Zum Verschrauben in 10x10mm-Lochung, sehr stabil
To bolt together with panel, very solid

Art.-Nr. / No.		EUR
8141 0230	310 x 220mm	8,20

ÜBERSICHT	MASSE	MODULE	Haken Hooks									
Compact	 <table border="1"> <tr> <td>ABS Mini 155 x 320</td> <td>ABS Mini 155 x 320</td> <td>ABS Mini 155 x 320</td> </tr> </table> <p>Schubladen-Innenmaß Drawer inside measurements 525 x 325mm</p>	ABS Mini 155 x 320	ABS Mini 155 x 320	ABS Mini 155 x 320	ABS Mini							
ABS Mini 155 x 320	ABS Mini 155 x 320	ABS Mini 155 x 320										
Quadro	 <table border="1"> <tr> <td>ABS Mini 155 x 320</td> <td>ABS Mini 155 x 320</td> <td>ABS Mini 155 x 320</td> </tr> </table> <p>Schubladen-Innenmaß Drawer inside measurements 442 x 350mm</p>	ABS Mini 155 x 320	ABS Mini 155 x 320	ABS Mini 155 x 320	ABS Mini MTS Q ModuFlex	10x10						
ABS Mini 155 x 320	ABS Mini 155 x 320	ABS Mini 155 x 320										
Servant	 <table border="1"> <tr> <td colspan="3">8158 00 96</td> </tr> <tr> <td>ABS Mini 155 x 320</td> <td>ABS Mini 155 x 320</td> <td>ABS Mini 155 x 320</td> </tr> <tr> <td colspan="3">8158 00 95</td> </tr> </table> <p>Schubladen-Innenmaß Drawer inside measurements 495 x 335mm</p>	8158 00 96			ABS Mini 155 x 320	ABS Mini 155 x 320	ABS Mini 155 x 320	8158 00 95			ABS Mini ModuFlex	Euro
8158 00 96												
ABS Mini 155 x 320	ABS Mini 155 x 320	ABS Mini 155 x 320										
8158 00 95												
Multi	 <table border="1"> <tr> <td>ABS Maxi 185 x 350</td> <td>ABS Maxi 185 x 350</td> <td>ABS Maxi 185 x 350</td> </tr> </table> <p>Schubladen-Innenmaß Drawer inside measurements 566 x 415mm</p>	ABS Maxi 185 x 350	ABS Maxi 185 x 350	ABS Maxi 185 x 350	ABS Maxi (MTS) (ModuFlex)	Euro						
ABS Maxi 185 x 350	ABS Maxi 185 x 350	ABS Maxi 185 x 350										
Combi	 <table border="1"> <tr> <td>ABS Maxi 185 x 350</td> <td>ABS Maxi 185 x 350</td> <td>ABS Maxi 185 x 350</td> </tr> </table> <p>Schubladen-Innenmaß Drawer inside measurements 566 x 415mm</p>	ABS Maxi 185 x 350	ABS Maxi 185 x 350	ABS Maxi 185 x 350	ABS Maxi MTS ModuFlex							
ABS Maxi 185 x 350	ABS Maxi 185 x 350	ABS Maxi 185 x 350										
CombiPlus	 <table border="1"> <tr> <td>ABS Maxi 185 x 350</td> <td>ABS Maxi 185 x 350</td> <td>ABS Maxi 185 x 350</td> </tr> </table> <p>Schubladen-Innenmaß Drawer inside measurements 566 x 415mm</p>	ABS Maxi 185 x 350	ABS Maxi 185 x 350	ABS Maxi 185 x 350	ABS Maxi MTS ModuFlex							
ABS Maxi 185 x 350	ABS Maxi 185 x 350	ABS Maxi 185 x 350										
Maxi	 <table border="1"> <tr> <td>ABS Maxi 185 x 350</td> <td>ABS Maxi 185 x 350</td> <td>ABS Maxi 185 x 350</td> </tr> </table> <p>Schubladen-Innenmaß Drawer inside measurements 578 x 410mm</p>	ABS Maxi 185 x 350	ABS Maxi 185 x 350	ABS Maxi 185 x 350	ABS Maxi MTS	10x10						
ABS Maxi 185 x 350	ABS Maxi 185 x 350	ABS Maxi 185 x 350										
Flexi	 <table border="1"> <tr> <td colspan="3">Schubladen-Innenmaß Drawer inside measurements 560 x 290mm</td> </tr> </table>	Schubladen-Innenmaß Drawer inside measurements 560 x 290mm			ModuFlex	10x10						
Schubladen-Innenmaß Drawer inside measurements 560 x 290mm												



Werkstatwagen
Trolleys

Go ModuFlex.

Schlüssel Wrenches

Doppelmaulschlüssel	Double Open Ended Spanners
Mini-Doppelmaulschlüssel	Midget Spanners
Magnetschlüssel	Magneto Spanners
Stockschrauben-Schlüssel	Sanitary Wrenches
Ring-Maulschlüssel	Combination Spanners
Ringmaul-Ratschenschlüssel	Combination Ratchet Spanners
Rollgabelschlüssel	Adjustable Wrenches
Doppelringschlüssel	Double Ended Ring Spanners
Starter- und Blockschlüssel	Starter and Manifold Spanners
TORX-Doppelringschlüssel	TORX-Double Ended Ring Spanners
Doppelring-Ratschenschlüssel	Double Ended Ring Ratchet Spanners
Offene Doppelringschlüssel	Flare Nut Ring Spanners
Massive Doppelsteckschlüssel	Box Spanners
Doppelgelenksteckschlüssel	Double Ended Swivel Spanners
Pfeifenkopfschlüssel	Pipe Head Spanners (L-Type)
Rohrsteckschlüssel	Tubular Box Spanners
Schlag-Maulschlüssel	Open Ended Slogging Spanners
Schlag-Ringschlüssel	Striking Face Ring Spanners
Zug-Ringschlüssel	Heavy Duty Ring Spanners



Inhalt Index



Schlüssel Wrenches



Schlüssel / Wrenches

Doppelmaulschlüssel Double Open Ended Spanners



100

DIN 3110 / ISO 3318 / 1085, Maulstellung 15°, Chrom-Vanadium-Stahl 31 CrV 3, voll galvanische Behandlung (vernickelt und verchromt), matt verchromt, extra geschliffene Flächen, Prägung "Made in Germany"

DIN 3110 / ISO 3318 / 1085, jaws set at 15°, Chrome-Vanadium-Steel 31 CrV 3 (1.2208), full galvanic treatment (nickel and chromium plated), matt chrome finish, precision sizing, stamped with "Made in Germany"

Art.-Nr. / No.	AF	mm	g	VE	EUR
0100 01 01	1/4 x 5/16	125	20	10	3,50
0100 01 02	5/16 x 3/8	140	30	10	3,90
0100 01 03	3/8 x 7/16	155	45	10	4,25
0100 01 04	7/16 x 1/2	172	65	10	4,70
0100 01 05	1/2 x 9/16	188	85	10	5,35
0100 01 06	9/16 x 5/8	188	85	10	5,35
0100 01 08	5/8 x 11/16	205	115	10	5,60
0100 01 10	11/16 x 3/4	220	150	10	7,15
0100 01 12	3/4 x 25/32	235	195	10	7,20
0100 01 15	13/16 x 7/8	235	195	10	8,30
0100 01 18	15/16 x 1	265	300	10	10,40
0100 01 35	1 x 1.1/8	282	390	10	11,40
0100 01 20	1.1/16x1.1/4	300	460	10	14,50

Art.-Nr. / No.	mm	mm	g	VE	EUR
0100 00 01	4 x 5	103	22	10	3,70
0100 00 02	5 x 5,5	104	22	10	3,70
0100 00 50	5,5 x 7	122	22	10	3,85
0100 00 03	6 x 7	125	20	10	3,35
0100 00 05	8 x 9	140	30	10	3,55
0100 00 06	8 x 10	140	30	10	3,75
0100 00 09	10 x 11	155	45	10	4,15
0100 00 10	10 x 12	155	45	10	4,15
0100 00 11	10 x 13	162	45	10	4,20
0100 00 12	12 x 13	172	65	10	4,70
0100 00 15	13 x 14	172	65	10	4,70
0100 00 16	13 x 15	188	85	10	4,80
0100 00 17	14 x 15	188	85	10	5,30
0100 00 18	13 x 17	205	105	10	5,50
0100 00 19	14 x 17	205	110	10	5,50
0100 00 20	16 x 17	205	115	10	5,70
0100 00 54	16 x 18	205	115	10	5,70
0100 00 21	17 x 19	220	150	10	5,80
0100 00 22	18 x 19	220	160	10	6,65
0100 00 23	19 x 22	235	195	10	6,95
0100 00 24	20 x 22	235	195	10	7,70
0100 00 25	21 x 23	248	235	10	8,10
0100 00 27	22 x 24	248	235	10	8,40
0100 00 28	24 x 26	265	300	10	8,60
0100 00 30	24 x 27	265	300	10	9,95
0100 00 31	25 x 28	282	390	10	11,00
0100 00 34	27 x 30	300	460	10	12,70
0100 00 35	27 x 32	300	460	10	14,30
0100 00 36	30 x 32	300	480	10	14,30
0100 00 37	30 x 36	325	645	10	18,50
0100 00 38	32 x 36	325	680	5	21,40
0100 00 39	36 x 41	360	900	5	28,40
0100 00 40	41 x 46	400	1120	5	39,20
0100 00 41	46 x 50	450	1625	5	54,10

Sätze Sets



Art.-Nr. / No.		g	EUR
Im Plastikhalter / in plastic hanger:			
0103 00 40	4-tlg. / pcs. 6 x 7, 8 x 9, 10 x 11, 12 x 13mm	300	10,50
0103 00 41	4-tlg. / pcs. 14 x 15, 16 x 17, 18 x 19, 20 x 22mm	900	16,00
Im Sichtkarton / in display box:			
0104 00 42	6-tlg. / pcs. 8 x 9, 10 x 11, 12 x 13, 14 x 15, 16 x 17, 18 x 19mm	500	18,20
0105 00 43	8-tlg. / pcs. 6 x 7, 8 x 9, 10 x 11, 12 x 13, 14 x 15, 16 x 17, 18 x 19, 20 x 22mm	740	22,00
0107 00 44	10-tlg. / pcs. 6 x 7, 8 x 9, 10 x 11, 12 x 13, 14 x 15, 16 x 17, 18 x 19, 20 x 22, 24 x 27, 30 x 32mm	1550	36,00
0114 00 46	12-tlg. / pcs. 6 x 7, 8 x 9, 10 x 11, 12 x 13, 14 x 15, 16 x 17, 18 x 19, 20 x 22, 21 x 23, 24 x 27, 25 x 28, 30 x 32mm	2150	39,00
0108 01 51	8-tlg. AF / pcs. 1/4 x 5/16, 5/16 x 3/8, 7/16 x 1/2, 9/16 x 5/8, 11/16 x 3/4, 13/16 x 7/8, 15/16 x 1, 1.1/16 x 1.1/4"	1415	57,00
0112 01 52	12-tlg. AF / pcs. 1/4 x 5/16, 5/16 x 3/8, 3/8 x 7/16, 7/16 x 1/2, 1/2 x 9/16, 9/16 x 5/8, 5/8 x 11/16, 3/4 x 25/32, 13/16 x 7/8, 15/16 x 1, 1x1.1/8, 1.1/16 x 1.1/4"	2025	83,90

Art.-Nr. / No.	mm	mm	g	VE	EUR	145
0145 00 01	5 x 5	80	10	10	1,95	<p>Mit gleichen Schlüsselweiten und extra dünnen Köpfen, Maulstellung 82,5° und 15°, Chrom-Vanadium-Stahl 31 CrV 3, voll galvanische Behandlung (vernickelt und verchromt), hochglanz-verchromt, ideal für enge Platzverhältnisse</p> <p>Same size at both ends, extra thin jaws, jaws set at 82,5° and 15°, Chrome-Vanadium-Steel 31 CrV 3 (1.2208), nickel and chromium plated, mirror polished, ideal for electricians</p>
0145 00 02	5,5 x 5,5	80	10	10	2,30	
0145 00 03	6 x 6	80	10	10	2,50	
0145 00 04	7 x 7	90	10	10	2,75	
0145 00 05	8 x 8	95	10	10	2,95	
0145 00 06	9 x 9	100	10	10	3,45	
0145 00 07	10 x 10	105	10	10	3,65	
0145 00 08	11 x 11	115	10	10	4,15	
0145 00 10	8-tlg. pcs.		85		13,95	Satz in Rolltasche / Set in roll bag

Mini-Doppelmaulschlüssel

Double Open Ended Midget Spanners



Art.-Nr. / No.		g	EUR	150
0150 60 01	44-tlg. / pcs.	280	78,00	

Inhalt / Content:

- Mini-Doppelmaulschlüssel / DE Midget Spanners 5x5; 5,5x5,5; 6x6; 7x7; 8x8; 9x9; 10x10; 11x11mm
- Präzisions-Schraubendreher / Precision screwdrivers Schlitz / Slotted 1,0x50; 2,0x50; Phillips P00, P1
- 1/4"-Mini-Umschaltknarre, feinverzahnt, 92mm 1/4"-Mini Ratchet, 72T, 92mm
- Bit-Adapter für Bohrmaschine
- Bits PH 1, 2, 3, 4; PZ 1, 2, 3, 4; Schlitz / Slotted 3, 4, 5, 6; Innensechskant / Hex 3, 4, 5, 6; TORX TX 10, 15, 20, 25, 27, 30, 40; Tamper-TORX TX 10, 15, 20, 25, 27, 30, 40

MTS-Elektroniker-Satz, 44-tlg.

MTS-Set for electricians, 44-pcs.



Art.-Nr. / No.	mm	g	VE	EUR	158
0158 00 01	4 - 7,5	50	10	4,70	

Satz am Ring, aus Stahlblech, vernickelt, beinhaltet:

- 8 Magnetschlüssel 4; 4,5; 5; 5,5; 6; 6,5; 7; 7,5
- 1 Schraubendreher / 1 Kontakfeile
- 1 Fühlerlehrenblatt

Set on ring, nickel plated, contains

- 8 DOE Spanners 4; 4,5; 5; 5,5; 6; 6,5; 7; 7,5
- 1 Screwdriver / 1 Contact File
- 1 Feeler Gauge

Magnetschlüssel-Satz, 10-tlg.

Set of Magneto Spanners, 10-pcs.



Art.-Nr. / No.	mm	mm	g	VE	EUR	159
0159 00 01	17 x 19	220	150	10	6,45	

Für Stockschrauben M10, z.B. an Waschbeckenbefestigungen, Chrom-Vanadium-Stahl 31 CrV 3, voll galvanische Behandlung (vernickelt und verchromt), matt verchromt

For sanitary screws M10, Chrome-Vanadium-Steel 31 CrV 3 (1.2208), full galvanic treatment (nickel and chromium plated), matt chrome finish

Präzise Toleranzen durch automatische Bearbeitung
Precision sizing due to fully automatic machining

Stockschrauben-Schlüssel

Sanitary Wrench



Schlüssel / Wrenches

Ring-Maulschlüssel DIN 3113 A Combination Spanners DIN 3113 A



185

DIN 3113 A / ISO 3318, Maul- und Ringstellung 15°, Chrom-Vanadium-Stahl 31 CrV 3, voll galvanische Behandlung (vernickelt und verchromt), matt verchromt, Prägung "Made in Germany"

DIN 3113 A / ISO 3318, jaws and ring side set at 15°, Chrome-Vanadium-Steel 31 CrV 3 (1.2208), full galvanic treatment (nickel and chromium plated), matt chrome finish, stamped with "Made in Germany"

Art.-Nr. / No.	AF	mm	g	VE	EUR
0185 01 01	1/4	105	20	10	4,35
0185 01 02	5/16	130	30	10	4,80
0185 01 03	3/8	154	50	10	5,10
0185 01 04	7/16	166	60	10	5,20
0185 01 05	1/2	190	80	10	5,90
0185 01 06	9/16	203	100	10	6,50
0185 01 07	5/8	227	135	10	6,90
0185 01 08	11/16	239	160	10	7,60
0185 01 09	3/4	263	205	10	8,90
0185 01 10	13/16	275	235	10	9,80
0185 01 11	7/8	300	300	10	11,20
0185 01 12	15/16	300	300	10	12,70
0185 01 13	1	330	380	5	13,90
0185 01 14	1.1/16	360	475	5	16,30
0185 01 15	1.1/8	360	475	5	16,40
0185 01 16	1.1/4	420	775	5	20,90

Art.-Nr. / No.	mm	mm	g	VE	EUR
0185 00 01	6	105	20	10	4,45
0185 00 02	7	117	20	10	4,60
0185 00 03	8	130	30	10	4,70
0185 00 04	9	142	40	10	4,70
0185 00 05	10	154	50	10	4,90
0185 00 06	11	166	60	10	5,00
0185 00 07	12	178	70	10	5,50
0185 00 08	13	190	80	10	5,95
0185 00 09	14	203	100	10	6,25
0185 00 10	15	215	115	10	6,65
0185 00 11	16	227	135	10	7,05
0185 00 12	17	239	160	10	7,85
0185 00 13	18	251	170	10	8,30
0185 00 14	19	263	205	10	8,95
0185 00 15	20	275	235	10	10,10
0185 00 16	21	288	260	10	10,20
0185 00 17	22	300	300	10	10,20
0185 00 18	23	300	300	10	12,50
0185 00 19	24	330	380	10	12,95
0185 00 21	26	360	475	10	14,10
0185 00 22	27	360	475	5	15,95
0185 00 23	28	360	475	5	17,40
0185 00 25	30	390	635	5	18,80
0185 00 26	32	420	775	5	21,10



Sätze Sets



Art.-Nr. / No.	g	EUR
Im Plastikhalter / in plastic hanger:		
0185 00 40	4-tlg. / pcs.: 8, 9, 10, 11mm	300 11,95
0185 00 41	4-tlg. / pcs.: 13, 14, 17, 19mm	540 17,95
Im Sichtkarton / in display box:		
0185 00 51	8-tlg. / pcs. 8, 10, 11, 13, 14, 17, 19, 22mm	840 26,00
0185 00 52	10-tlg. / pcs. 6-11, 13, 14, 17, 19mm	655 34,90
0185 00 53	12-tlg. / pcs. 8-19mm	1020 39,00
0185 00 56	12-tlg. / pcs. 6, 7, 8, 9, 10, 11, 13, 14, 17, 19, 20, 22mm	995 44,50
0185 01 51	8-tlg. AF / pcs. 5/16, 3/8, 7/16, 1/2, 9/16, 5/8, 11/16, 3/4"	710 49,00
0185 01 52	10-tlg. AF / pcs. 1/4, 5/16, 3/8, 7/16, 1/2, 9/16, 5/8, 11/16, 3/4, 7/8"	965 65,00
0185 01 53	12-tlg. AF / pcs. 5/16, 3/8, 7/16, 1/2, 9/16, 5/8, 11/16, 3/4, 13/16, 7/8, 15/16, 1"	1735 95,00
Im Karton / in cardboard box:		
0185 00 54	16-tlg. / pcs. 6-14, 17, 19, 22, 24, 27, 30, 32mm	2670 85,50
0185 00 55	17-tlg. / pcs. 6-22mm	1690 69,00

186

Ringmaul-Ratschenschlüssel VA
Combination Ratchet Spanners

Art.-Nr. / No.	mm	mm	g	VE	EUR
0186 00 80	8	149	45	10	18,90
0186 00 90	9	149	66	10	19,90
0186 01 00	10	159	70	10	20,90
0186 01 10	11	165	80	10	21,90
0186 01 20	12	171	92	10	22,90
0186 01 30	13	178	96	10	23,90
0186 01 40	14	190	116	10	24,90
0186 01 50	15	199	124	10	25,90
0186 01 60	16	208	150	10	26,90
0186 01 70	17	225	180	5	27,90
0186 01 80	18	236	195	5	28,90
0186 01 90	19	248	220	5	29,90
0186 00 01	6-tlg. / pcs.		750		84,90
	8, 10, 11, 13, 17, 19mm				
0186 00 02	8-tlg. / pcs.		1095		119,90
	8, 10, 11, 13, 16, 17, 18, 19mm				



- Ringmaulschlüssel mit Ratschentechnik
- Ideal für den Außenbereich (z.B. Boot, Bau, Landwirtschaft, Strassenbau usw.), da Edelstahl nicht rosten kann
 - Ratschentechnik mit 72 Zähnen
 - Original MULTIGEAR-Getriebe - US-Patent! - für extrem lange Lebensdauer
 - Arbeitswinkel 5°
 - Sehr hohe Drehmomentwerte (z.B. Ring SW 19mm laut DIN = 261Nm, unser Schlüssel = 450Nm = +72% über DIN!)
 - Kein Abplatzen von Chrom
 - Arbeitsrichtung der Ratsche durch Ringform vorgegeben

- Combination Ratchet Spanners
- Ideal for outdoor works (e.g. boats, construction sites, agriculture, etc.) due to the fact that stainless steel cannot become rusty
 - Ratchet-technique with 72 teeth, re-engages after movement of 5°
 - Original MULTIGEAR-Ratchet technique - US-Patent - for extra long life
 - Extremely high torque performance (i.e. ring size 19mm: 261 Nm as DIN standard; 450 Nm our Spanners = 72% above DIN standard!)
 - No more chrome-peeling

Sätze in Kartonverpackung / Sets in cardboard box



VA-MATERIAL / STAINLESS STEEL



Schlüssel
Wrenches

590

Rollgabelschlüssel Profi
Adjustable Wrenches Profi

Art.-Nr. / No.	mm	mm	g	VE	EUR
0590 00 01	4" - 110	15	55	1	16,90
0590 00 02	6" - 155	19	120	1	18,10
0590 00 03	8" - 205	24	240	1	21,30
0590 00 04	10" - 255	29	410	1	26,80
0590 00 05	12" - 310	33	675	1	35,70
0590 00 06	15" - 380	44	1230	1	59,50
0590 00 07	18" - 450	56	2100	1	93,50

- Rollgabelschlüssel, verstellbar, System Crescent, mit präziser Skala zum Einstellen der Maulweite, DIN 3117 A / ISO 6787, schwedische Form, Chrom-Vanadium-Stahl 31 CrV 3, voll galvanische Behandlung (vernickelt und verchromt), matt verchromt, Köpfe poliert

- Adjustable Wrenches, System Crescent, with precision scale for adjusting the jaw, DIN 3117 A / ISO 6787, Swedish type, Chrome-Vanadium-Steel 31 CrV 3 (1.2208), full galvanic treatment (nickel and chromium plated), matt chrome finish, polished heads



591

Rollgabelschlüssel Basic
Adjustable Wrenches Basic

Art.-Nr. / No.	mm	mm	g	VE	EUR
0591 00 02	6" - 155	19	120	1	8,50
0591 00 03	8" - 205	24	240	1	9,50
0591 00 04	10" - 255	29	410	1	10,50
0591 00 05	12" - 310	33	675	1	11,50



- Rollgabelschlüssel, verstellbar, mit Skala zum Einstellen der Maulweite, DIN 3117 A / ISO 6787, Chrom-Vanadium-Stahl 31 CrV 3, matt verchromt

- Adjustable Wrenches, with precision scale for adjusting the jaw, DIN 3117 A / ISO 6787, Chrome-Vanadium-Steel 31 CrV 3 (1.2208), matt chrome finish



Schlüssel / Wrenches

Ring-Maulschlüssel DIN 3113 B Combination Spanners DIN 3113 B



190

DIN 3113 B / ISO 3318, gekröpft, lange Form, Chrom-Vanadium-Stahl 31 CrV 3, voll galvanische Behandlung (vernickelt / verchromt), matt verchromt, Prägung "Made in Germany", bis 32mm Ring poliert

DIN 3113 B / ISO 3318, offset, Chrome-Vanadium-Steel 1.2208, full galvanic treatment (nickel and chromium plated), matt chrome finish, stamped with "Made in Germany", ring polished up to 32mm

Art.-Nr. / No.	AF	mm	g	VE	EUR
0190 01 01	1/4	110	20	10	5,42
0190 01 02	5/16	130	30	10	5,74
0190 01 03	3/8	150	50	10	5,95
0190 01 04	7/16	160	55	10	6,07
0190 01 05	1/2	175	75	10	6,72
0190 01 06	9/16	185	90	10	7,80
0190 01 07	19/32	195	105	10	8,34
0190 01 08	5/8	210	120	10	9,32
0190 01 09	11/16	225	135	10	9,54
0190 01 10	3/4	250	200	10	11,16
0190 01 12	13/16	285	240	10	13,11
0190 01 13	7/8	295	265	10	13,44
0190 01 14	15/16	395	365	10	17,23
0190 01 15	1	329	400	10	19,07
0190 01 16	1.1/16	360	485	5	20,91
0190 01 17	1.1/8	360	485	5	21,46
0190 01 18	1.1/4	435	780	5	28,39
0190 01 30	1.5/16	435	780	5	41,83
0190 01 19	1.3/8	465	1000	5	41,83
0190 01 20	1.7/16	468	1000	5	51,37
0190 01 21	1.1/2	505	1400	5	51,37
0190 01 22	1.5/8	505	1370	5	28,39
0190 01 31	1.11/16	470	1250	5	66,75
0190 01 32	1.3/4	520	1900	5	117,47
0190 01 33	1.13/16	520	1900	5	117,47
0190 01 34	1.7/8	520	1900	5	117,47
0190 01 35	2	560	2350	1	144,02

Art.-Nr. / No.	mm	mm	g	VE	EUR
0190 00 01	6	110	20	10	5,60
0190 00 02	7	120	25	10	5,60
0190 00 03	8	130	30	10	5,60
0190 00 04	9	140	35	10	6,05
0190 00 05	10	150	50	10	6,15
0190 00 06	11	160	55	10	6,35
0190 00 07	12	167	65	10	6,85
0190 00 08	13	175	75	10	6,85
0190 00 09	14	185	90	10	7,70
0190 00 10	15	195	105	10	8,65
0190 00 11	16	210	120	10	9,20
0190 00 12	17	225	135	10	9,55
0190 00 13	18	237	155	10	11,25
0190 00 14	19	250	200	10	11,55
0190 00 15	20	267	240	10	11,70
0190 00 16	21	283	250	10	13,45
0190 00 17	22	295	265	10	13,65
0190 00 18	23	295	265	10	13,70
0190 00 19	24	329	400	10	17,70
0190 00 20	25	329	400	10	19,65
0190 00 21	26	360	400	5	20,20
0190 00 22	27	360	485	5	21,10
0190 00 23	28	360	485	5	21,65
0190 00 40	29	394	610	5	21,80
0190 00 24	30	394	610	5	24,70
0190 00 25	32	435	780	5	27,40
0190 00 41	33	440	780	5	28,20
0190 00 26	36	468	1000	5	42,50
0190 00 27	38	505	1300	5	46,40
0190 00 28	41	505	1300	5	47,20
0190 00 29	46	520	1900	5	91,00
0190 00 30	50	560	2350	1	111,00
0190 00 31	55	610	2850	1	157,00
0190 00 32	60	660	3600	1	215,00
0190 00 33	65	710	4550	1	263,00
0190 00 34	70	760	5800	1	290,00
0190 00 35	75	810	6650	1	343,00
0190 00 36	80	860	8500	1	408,00

Sätze Sets



Art.-Nr. / No.		g	EUR
Im Sichtkarton / in display box:			
0190 00 51	8-tlg. / pcs. 8, 10, 11, 13, 14, 17, 19, 22mm	940	35,00
0190 00 52	10-tlg. / pcs. 6, 7, 8, 9, 10, 11, 13, 14, 17, 19mm	735	39,00
0190 00 53	12-tlg. / pcs. 8 - 19mm	1175	49,00
0190 01 51	8-tlg. AF / pcs. 5/16, 3/8, 7/16, 1/2, 9/16, 5/8, 11/16, 3/4"	785	57,50
0190 01 52	10-tlg. AF / pcs. 1/4, 5/16, 3/8, 7/16, 1/2, 9/16, 5/8, 11/16, 3/4, 7/8"	1085	75,00
0190 01 53	12-tlg. AF / pcs. 5/16, 3/8, 7/16, 1/2, 9/16, 5/8, 11/16, 3/4, 13/16, 7/8, 15/16, 1"	2105	115,50
Im Karton / in cardboard box:			
0190 00 54	16-tlg. / pcs. 6 - 14, 17, 19, 22, 24, 27, 30, 32mm	3220	95,00
0190 00 55	17-tlg. / pcs. 6 - 22mm	1920	79,50
0190 00 56	26-tlg. / pcs. 6 - 30, 32mm	6185	168,00
0190 01 54	16-tlg. AF / pcs. 1/4, 5/16, 3/8, 7/16, 1/2, 9/16, 19/32, 5/8, 11/16, 3/4, 13/16, 7/8, 15/16, 1, 1.1/16, 1.1/4"	3365	174,00

Art.-Nr. / No.	mm	mm	g	VE	EUR
0200 00 02	6 x 7	175	55	10	7,50
0200 00 04	8 x 9	191	75	10	7,90
0200 00 05	8 x 10	191	70	10	8,20
0200 00 07	10 x 11	206	105	10	8,70
0200 00 08	10 x 12	210	110	10	8,95
0200 00 09	10 x 13	216	112	10	9,20
0200 00 11	12 x 13	221	135	10	9,45
0200 00 12	12 x 14	230	150	10	9,70
0200 00 13	13 x 15	235	165	10	9,85
0200 00 14	14 x 15	235	165	10	10,05
0200 00 15	13 x 17	251	215	10	10,50
0200 00 17	16 x 17	251	210	10	10,65
0200 00 43	16 x 18	265	255	10	11,80
0200 00 18	17 x 19	271	270	10	12,20
0200 00 19	18 x 19	271	270	10	12,35
0200 00 20	19 x 22	290	330	10	14,15
0200 00 21	20 x 22	291	335	10	14,60
0200 00 22	21 x 23	311	400	5	16,45
0200 00 24	22 x 24	311	400	5	16,40
0200 00 25	24 x 26	331	495	5	17,90
0200 00 27	24 x 27	331	495	5	18,10
0200 00 28	25 x 28	352	565	5	20,30
0200 00 32	27 x 32	371	640	5	22,40
0200 00 33	30 x 32	371	640	5	23,45
0200 00 34	30 x 36	401	880	5	34,80
0200 00 35	32 x 36	401	890	5	35,20
0200 00 36	36 x 41	439	1100	5	43,50
0200 00 37	41 x 46	486	1390	5	56,50
0200 00 38	46 x 50	536	1955	1	79,50
0200 00 39	55 x 60	612	3250	1	169,00

200

Doppelringschlüssel

Double Ended Ring Spanners

Doppelringschlüssel tiefgekröpft, DIN 838 / ISO 3318, Chrom-Vanadium-Stahl 31 CrV 3, voll galvanische Behandlung (vernickelt und verchromt), matt verchromt, extra polierte Ringköpfe, Prägung "Made in Germany"

Double Ended Ring Spanners, deep offset, DIN 838 / ISO 3318, Chrome-Vanadium-Steel 31 CrV 3 (1.2208), full galvanic treatment (nickel and chromium plated), matt chrome finish, polished ring heads, stamped with "Made in Germany"

Art.-Nr. / No.	AF	mm	g	VE	EUR
0200 01 01	1/4 x 5/16	175	55	10	7,60
0200 01 03	3/8 x 7/16	206	105	10	8,80
0200 01 04	7/16 x 1/2	221	130	10	9,45
0200 01 05	1/2 x 9/16	221	145	10	9,65
0200 01 08	5/8 x 11/16	251	210	10	10,70
0200 01 11	3/4 x 25/32	271	270	10	12,60
0200 01 14	13/16 x 7/8	291	335	10	14,50
0200 01 17	15/16 x 1	311	435	5	18,90
0200 01 19	1.1/16x1.1/4	371	640	5	23,40
0200 01 36	1.3/16x1.5/16	371	640	5	23,75
0200 01 22	1.3/8x1.1/2	420	1000	5	45,80
0200 01 23	1.7/16x1.5/8	439	1100	5	51,90
0200 01 40	1.11/16x1.7/8	495	1400	5	63,50
0200 01 41	1.13/16x2	535	1955	1	85,00



SK-Profil für mehr Kraft an den Flanken. An allen Ringschlüsseln und Einsätzen von MATADOR.

SK Profile for higher power transmission. Find it on all ring spanners and sockets from MATADOR.



Schlüssel
Wrenches

Art.-Nr. / No.		g	EUR
Im Sichtkarton / in display box:			
0204 00 43	6-tlg. / pcs. 8 x 9, 10 x 11, 12 x 13, 14 x 15, 16 x 17, 18 x 19mm	885	33,00
0205 00 44	8-tlg. / pcs. 6 x 7, 8 x 9, 10 x 11, 12 x 13, 14 x 15, 16 x 17, 18 x 19, 20 x 22mm	1265	35,00
0206 01 24	6-tlg. AF / pcs. 3/8 x 7/16, 1/2 x 9/16, 5/8 x 11/16, 3/4 x 25/32, 13/16 x 7/8, 15/16 x 1"	1500	72,50
0211 01 26	8-tlg. AF / pcs. 1/4 x 5/16, 3/8 x 7/16, 1/2 x 9/16, 5/8 x 11/16, 3/4 x 25/32, 13/16 x 7/8, 15/16 x 1, 1.1/16 x 1.1/4"	2180	99,50
Im Karton / in cardboard box:			
0207 00 45	10-tlg. / pcs. 6 x 7, 8 x 9, 10 x 11, 12 x 13, 14 x 15, 16 x 17, 18 x 19, 20 x 22, 24 x 27, 30 x 32mm	2355	74,00
0214 00 47	12-tlg. / pcs. 6 x 7, 8 x 9, 10 x 11, 12 x 13, 14 x 15, 16 x 17, 18 x 19, 20 x 22, 21 x 23, 24 x 27, 25 x 28, 30 x 32mm	3310	83,00

Sätze

Sets



Schlüssel / Wrenches

Starter- und Blockschlüssel Starter and Manifold Spanners



188

Starter- und Blockschlüssel, ideal für Arbeiten am Motorblock, z.B. für Schrauben an Lichtmaschine, Vergaser und Anlasser, Chrom-Vanadium-Stahl 31 CrV 3, voll galvanische Behandlung (vernickelt und verchromt), matt verchromt

Starter and Manifold Spanners, perfect for works on engines e.g. bolts on alternator, carburettor and starter, Chrome-Vanadium-Steel 31 CrV 3 (1.2208), full galvanic treatment (nickel and chromium plated), matt chrome finish

Art.-Nr. / No.	mm	mm	g	VE	EUR
0188 00 07	10 x 12	145	80	10	11,50
0188 00 01	11 x 13	145	70	10	11,80
0188 00 02	13 x 15	165	100	10	12,50
0188 00 03	14 x 16	185	150	10	12,70
0188 00 04	14 x 17	185	150	10	13,50
0188 00 05	15 x 17	185	150	10	13,70
0188 00 08	16 x 18	200	215	10	14,50
0188 00 06	19 x 22	235	265	10	18,50

Doppelringschlüssel, gerade DE Ring Spanners, straight



220

Doppelringschlüssel, gerade, DIN 837 / ISO 3318, Chrom-Vanadium-Stahl 31 CrV 3, voll galvanische Behandlung (vernickelt und verchromt), matt verchromt

Double Ended Ring Spanners, straight, DIN 837 / ISO 3318, Chrome-Vanadium-Steel 31 CrV 3 (1.2208), full galvanic treatment (nickel and chromium plated), matt chrome finish

Art.-Nr. / No.	mm	mm	g	VE	EUR
0220 00 01	6 x 7	100	10	10	5,40
0220 00 02	8 x 9	115	16	10	5,95
0220 00 03	8 x 10	120	20	10	6,05
0220 00 04	10 x 11	125	28	10	6,20
0220 00 05	12 x 13	140	40	10	6,75
0220 00 06	12 x 14	150	40	10	7,20
0220 00 07	13 x 15	155	45	10	7,50
0220 00 08	14 x 15	155	55	10	7,55
0220 00 09	13 x 17	160	60	10	8,40
0220 00 11	16 x 17	170	70	10	8,70
0220 00 28	16 x 18	170	80	10	8,90
0220 00 12	17 x 19	185	82	10	9,40
0220 00 13	18 x 19	188	80	10	9,55
0220 00 15	20 x 22	205	130	10	11,10
0220 00 16	21 x 23	222	135	10	11,65
0220 00 22	22 x 24	240	150	10	12,90
0220 00 18	24 x 27	255	195	5	13,90
0220 00 19	25 x 28	265	222	5	15,30
0220 00 21	30 x 32	285	280	5	18,85



Sätze in Kartonverpackung / Sets in cardboard box

0220 00 24	8-tlg. / pcs. 6 x 7, 8 x 9, 10 x 11, 12 x 13, 14 x 15, 16 x 17, 18 x 19, 20 x 22mm	430			36,50
0220 00 25	12-tlg. / pcs. 6 x 7, 8 x 9, 10 x 11, 12 x 13, 14 x 15, 16 x 17, 18 x 19, 20 x 22, 21 x 23, 24 x 27, 25 x 28, 30 x 32mm	1260			72,95

Doppelringschlüssel, TORX DE Ring Spanners, TORX



221

Doppelringschlüssel, gerade, für Außen-TORX-Schrauben, Chrom-Vanadium-Stahl 31 CrV 3, voll galvanische Behandlung (vernickelt und verchromt), matt verchromt

Double Ended Ring Spanners, straight, for outside TORX-screws, Chrome-Vanadium-Steel 31 CrV 3 (1.2208), full galvanic treatment (nickel and chromium plated), matt chrome finish

Satz in Kartonverpackung / Set in cardboard box

Art.-Nr. / No.	TORX	mm	g	VE	EUR
0221 06 08	E 6 x 8	110	25	10	10,20
0221 10 12	E 10 x 12	140	40	10	10,50
0221 14 18	E 14 x 18	180	80	10	11,70
0221 20 24	E 20 x 24	225	155	5	16,70
0221 00 01	4-tlg. / pcs.		300		48,90

Art.-Nr. / No.	mm	mm	g	VE	EUR
0224 00 01	6 x 7	110	50	10	18,50
0224 00 02	8 x 9	140	70	10	19,50
0224 00 03	10 x 11	175	80	10	20,50
0224 00 04	12 x 13	175	145	10	21,50
0224 00 05	14 x 15	205	150	10	22,50
0224 00 06	16 x 18	205	260	10	23,50
0224 00 07	17 x 19	205	260	10	24,50
0224 00 08	21 x 22	235	280	10	25,50
0224 00 50	8-tlg. / pcs.	1300			169,00

224

Ratschenringschlüssel, gekröpft
Double Box Wrenches, offset type

Doppelringschlüssel, mit Ratschentechnik, 72-Zähne, nur 5° Hebelbewegung, Hebelumschaltung für Rechts- und Linkslauf, hochlegierter Spezialstahl, Schäfte aus CrV-Stahl, verchromt, mit umlaufendem Kunststoffschutz

Double Ended Ring Spanners, with ratchet function, 72 T, right and left hand use, special steel, quick-flip reversing lever for instant ratchet reversal, laminated construction for great strength, chrome-plated

Satz in Kartonverpackung / Set in cardboard box



Art.-Nr. / No.	TORX	mm	g	VE	EUR
0226 00 01	E 6 x 7	110	50	10	20,50
0226 00 02	E 8 x 10	140	70	10	21,50
0226 00 03	E 11 x 12	175	80	10	22,50
0226 00 04	E 14 x 16	175	145	10	23,50
0226 00 05	E 18 x 20	205	150	10	24,50
0226 00 06	E 22 x 24	205	260	10	26,50
0226 00 50	6-tlg. / pcs.	1300			135,00

226

Ratschenringschlüssel, TORX
Double Box Wrenches, TORX

Doppelringschlüssel, gekröpft, mit Ratschentechnik, für Außen-TORX-Schrauben, 72-Zähne, nur 5° Hebelbewegung, Hebelumschaltung für Rechts- und Linkslauf, hochlegierter Spezialstahl, Schäfte aus CrV-Stahl, verchromt, mit umlaufendem Kunststoffschutz

Double Ended Ring Spanners, with ratchet function, 72 T, for outside TORX-screws, right and left hand use, special steel, offset type for more convenient use in confined spaces, quick-flip reversing lever for instant ratchet reversal, chrome-plated

Satz in Kartonverpackung / Set in cardboard box



Art.-Nr. / No.	mm	mm	g	VE	EUR
0230 08 09	8 x 9	160	110	1	35,00
0230 10 11	10 x 11	175	138	1	37,00
0230 12 13	12 x 13	205	188	1	39,00
0230 14 15	14 x 15	210	196	1	41,00
0230 16 17	16 x 17	240	332	1	43,00
0230 18 19	18 x 19	250	360	1	48,00
0230 00 01	6-tlg. / pcs.	1324			148,00
	8 x 9, 10 x 11, 12 x 13, 14 x 15, 16 x 17, 18 x 19mm				

230

Doppelring-Ratschenschlüssel
Double Ring Ratchet Spanners

Doppelgelenk-Ringschlüssel mit Ratschentechnik

- Ideal für den Außenbereich (z.B. Boot, Bau, Landwirtschaft, Strassenbau usw.), da Edelstahl nicht rosten kann!
- Doppel-Ratschentechnik mit 72 Zähnen
- Original MULTIGEAR-Getriebe - US-Patent! - für extrem lange Lebensdauer
- Extrem hohe Drehmomentwerte (z.B. Ring SW 19mm laut DIN = 261Nm, unser Schlüssel = 450Nm = +72% über DIN!)
- Kein Abplatzen von Chrom
- Schwenkwinkel 180°

Double-Ended Swivel-Ring-Ratchet-Spanners

- Ideal for outdoor works (e.g. boats, construction sites, agriculture, etc.) due to stainless steel cannot become rusty
- Ratchet-technique with 72 teeth, re-engages after movement of 5°
- Original MULTIGEAR-Ratchet technique - US-Patent - for extra long life
- Extremely high torque performance (i.e. ring size 19mm: 261 Nm as DIN standard; 450 Nm our Spanners = 72% above DIN standard!)
- No more chrome-peeling
- Max. angle 180°

Satz in Kartonverpackung / Set in cardboard box



VA-MATERIAL / STAINLESS STEEL



Schlüssel / Wrenches

Offene Doppelringschlüssel Flare Nut Ring Spanners



251

Offene Doppelringschlüssel für Überwurfmutter und -schrauben an Rohrleitungsverschraubungen, auch ideal für Bremsleitungen, DIN 3118, 8 x 10 - 13 x 14mm, 6-kant: Köpfe 30° geschlitzt, 15° abgewinkelt; 14 x 17 - 27 x 36mm, 12-kant: Köpfe 15° geschlitzt, 15° abgewinkelt, Chrom-Vanadium-Stahl 31 CrV 3, matt verchromt

Flare Nut Ring Spanners, chrome plated, Chrome-Vanadium, for screwed connections on brake lines, 8 x 10 - 13 x 14mm, 6-pt.: Heads 30° slotted, 15° offset; 14 x 17 - 27 x 36mm, 12-pt.: Heads 15° slotted, 15° offset, Chrome-Vanadium-Steel 31 CrV 3 (1.2208), matt chrome finish

Satz in Kartonverpackung / Set in cardboard box

Art.-Nr. / No.	mm	mm	g	VE	EUR
0251 00 01	8 x 10	140	45	10	11,10
0251 00 02	9 x 11	150	60	10	11,80
0251 00 03	10 x 11	150	65	10	11,80
0251 00 04	10 x 12	150	65	10	11,80
0251 00 14	11 x 13	170	95	10	11,80
0251 00 05	13 x 14	170	100	10	13,70
0251 00 06	14 x 17	200	145	10	14,20
0251 00 15	16 x 18	210	160	10	16,10
0251 00 07	17 x 19	210	155	10	16,10
0251 00 08	19 x 22	215	200	5	18,90
0251 00 13	22 x 24	235	275	5	24,00
0251 00 09	24 x 27	235	300	5	25,60
0251 00 11	30 x 32	275	450	5	33,50
0251 00 12	27 x 36	300	415	5	50,30
0251 00 90	8 x 10, 10 x 12, 11 x 13, 14 x 17, 19 x 22mm		550		39,75

Doppelsteckschlüssel, massiv Box Spanners



300

Doppelsteckschlüssel, mit Sechskant-Schaft, Innensechskant, massiv, geschmiedet, Chrom-Vanadium-Stahl 31 CrV 3, voll galvanische Behandlung (vernickelt und verchromt), matt verchromt

Box Spanner, with hexagon shaft, inside hexagon, solid wrought, Chrome-Vanadium-Steel 31 CrV 3 (1.2208), full galvanic treatment (nickel and chromium plated), matt chrome finish

Sätze in Kartonverpackung / Sets in cardboard box

Art.-Nr. / No.	mm	mm	g	VE	EUR
0300 00 01	6 x 7	115	40	10	14,95
0300 00 02	8 x 9	120	60	10	15,95
0300 00 03	10 x 11	130	75	10	16,95
0300 00 04	12 x 13	140	115	10	17,95
0300 00 05	14 x 15	150	140	10	18,95
0300 00 07	16 x 17	160	180	10	19,95
0300 00 09	18 x 19	170	225	10	20,95
0300 00 10	20 x 22	180	320	10	21,95
0300 00 11	21 x 23	180	330	5	22,95
0300 00 16	24 x 27	190	415	5	26,95
0300 00 17	25 x 28	200	500	5	28,95
0300 00 15	30 x 32	200	610	5	39,00
0300 00 91	8-tlg. / pcs.		1120		86,00
0300 00 92	6x7 - 20x22 12-tlg. / pcs. 6x7 - 30x32		3100		155,00

Stufen-Drehstift Pin handles, graduated



342

6-fach (4, 6, 8, 10, 12, 14mm), für Nr. 300 + 380; Chrom-Vanadium-Stahl 31 CrV 3, voll galvanische Behandlung, matt verchromt

Graduated, for No. 300 + 380; Chrome-Vanadium-Steel 31 CrV 3 (1.2208), full galvanic treatment, matt chrome finish

Art.-Nr. / No.	mm	mm	g	VE	EUR
0342 00 17	6-32	250	230	10	11,90

Doppelgelenksteckschlüssel Double Ended Swivel Spanners



430

Für enge Platzverhältnisse, Chrom-Vanadium-Stahl 31 CrV 3, voll galvanische Behandlung (vernickelt und verchromt), matt verchromt

Chrome-Vanadium-Steel 31 CrV 3 (1.2208), full galvanic treatment (nickel and chromium plated), matt chrome finish

Satz in Kartonverpackung / Set in cardboard box

Art.-Nr. / No.	mm / AF	mm	g	VE	EUR
0430 00 01	8 x 9	145	50	10	17,20
0430 00 02	10 x 11	170	75	10	19,80
0430 00 03	12 x 13	200	125	10	21,60
0430 00 04	14 x 15	220	245	10	24,50
0430 00 05	16 x 17	250	255	10	26,80
0430 00 06	18 x 19	270	340	10	28,20
0430 00 07	20 x 22	295	435	5	32,90
0430 01 01	3/8 x 7/16	210	112	10	24,20
0430 01 02	1/2 x 9/16	245	220	10	26,30
0430 00 90	7-tlg. / pcs. 8 x 9 - 20 x 22mm		1235		171,00

Art.-Nr. / No.	mm	mm	g	VE	EUR
0320 00 01	8	115	80	10	8,50
0320 00 02	9	122	85	10	8,65
0320 00 03	10	130	105	10	9,50
0320 00 04	11	136	115	5	10,20
0320 00 05	12	145	145	5	10,50
0320 00 06	13	152	170	5	10,70
0320 00 07	14	160	185	5	11,50
0320 00 08	15	170	215	5	12,70
0320 00 09	16	178	240	5	13,50
0320 00 10	17	187	275	5	13,70
0320 00 11	18	195	345	2	15,00
0320 00 12	19	205	385	2	15,30
0320 00 13	20	212	490	2	16,50
0320 00 14	21	225	550	2	17,50
0320 00 15	22	230	550	2	18,80
0320 00 16	23	240	715	2	20,80
0320 00 17	24	250	750	2	21,80
0320 00 18	26	270	885	2	26,35
0320 00 19	27	280	890	2	28,80
0320 00 20	28	290	920	2	32,10
0320 00 21	29	300	1120	2	34,50
0320 00 22	30	310	1220	2	39,00
0320 00 23	32	330	1570	2	42,00
0320 00 50	8-tlg. / pcs.	1900			95,00
	8, 10, 11, 13, 16, 17, 18, 19mm				
0320 00 51	12-tlg. / pcs.	2600			138,00
	8, 9, 10, 11, 12, 13, 14, 15, 16, 17, 18 19mm				

320
6-kt.-Pfeifenkopfschlüssel
 6-pt. Pipe Head Spanners

ISO 2236, ideal für Stehbolzen und tiefliegende Muttern, 6x12 (mit Sechs- u. Zwölfkant), kurze Seite gebohrt zum Einstecken von Drehstiften, Chrom-Vanadium-Stahl 31 CrV 3, voll galvanische Behandlung (vernickelt und verchromt), matt verchromt,

ISO 2236, 6x12 (with 6-pt. and 12-pt.), with insertion on short side for tommy bar, Chrome-Vanadium-Steel 31 CrV 3 (1.2208), full galvanic treatment (nickel and chromium plated), matt chrome finish

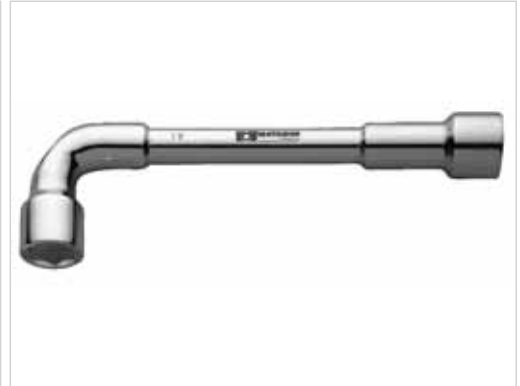
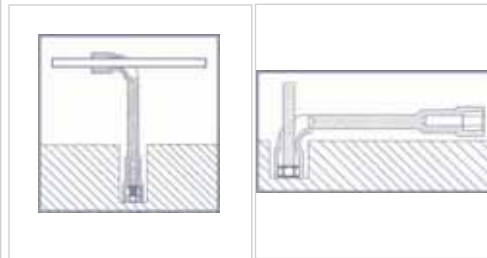

Sätze in Kartonverpackung / Sets in cardboard box



Art.-Nr. / No.	mm	mm	g	VE	EUR
0380 00 01	6 x 7	110	30	10	2,95
0380 00 02	8 x 9	110	40	10	3,10
0380 00 30	8 x 10	115	40	10	3,35
0380 00 03	10 x 11	120	55	10	3,45
0380 00 04	12 x 13	140	80	10	3,65
0380 00 05	13 x 15	140	85	10	3,80
0380 00 06	14 x 15	140	90	10	4,20
0380 00 08	16 x 17	155	125	10	4,50
0380 00 09	17 x 19	160	165	10	5,80
0380 00 10	18 x 19	160	165	10	6,30
0380 00 32	18 x 21	170	190	10	6,50
0380 00 11	20 x 22	170	200	10	6,85
0380 00 12	21 x 23	175	200	5	6,95
0380 00 14	24 x 27	185	295	5	7,85
0380 00 18	30 x 32	200	365	5	9,10
0380 00 19	32 x 36	220	455	5	12,50
0380 00 20	36 x 41	220	615	5	14,10
0380 00 21	41 x 46	240	775	5	16,60
0380 00 22	46 x 50	240	820	1	42,00
0380 00 50	8-tlg. / pcs.	850			34,00
	6 x 7, 8 x 9, 10 x 11, 12 x 13, 14 x 15, 16 x 17, 18 x 19, 20 x 22mm				
0380 00 51	12-tlg. / pcs.	2100			67,00
	6 x 7, 8 x 9, 10 x 11, 12 x 13, 14 x 15, 16 x 17, 18 x 19, 20 x 22, 21 x 23, 24 x 27, 25 x 28, 30 x 32mm				

380
Rohrsteckschlüssel
 Tubular Box Spanners

DIN 896 Form B / ISO 2236 / 1085, Spezialstahl, gehärtet, voll galvanische Behandlung (vernickelt und verchromt), matt verchromt, Prägung "Made in Germany"

DIN 896 Form B / ISO 2236 / 1085, special tool steel, hardened, full galvanic treatment (nickel and chromium plated), matt chrome finish, signed with "Made in Germany"

Sätze in Kartonverpackung / Sets in cardboard box

 Automatisches Bohrzentrum /
 Automatic Boring Center

Schlagschlüssel / Slogging Spanners

Schlag-Maulschlüssel Open Ended Slogging Spanners



175

DIN 133, für besonders schwere Montagen, bis Länge 500mm aus Chrom-Vanadium Stahl 31CrV3, ab Länge 525mm aus Werkstoff C35, gesandstrahlt, verzinkt für anhaltenden Rostschutz

For very heavy duty work, up to length 525mm Chrome-Vanadium steel 31CrV 3 (1.2208), above 545mm C35 steel, sand blasted, zinc plated

AF-Abmessungen auf Anfrage / AF-sizes on request

Art.-Nr. / No.	mm	mm	kg	VE	EUR
0175 00 01	27	180	0,35	1	15,60
0175 00 02	30	190	0,45	1	18,40
0175 00 03	32	190	0,45	1	19,40
0175 00 04	36	215	0,65	1	25,00
0175 00 05	41	235	0,95	1	31,00
0175 00 06	46	255	1,25	1	41,00
0175 00 07	50	275	1,60	1	47,00
0175 00 08	55	300	2,05	1	55,00
0175 00 09	60	320	2,45	1	62,00
0175 00 10	65	340	3,25	1	80,00
0175 00 11	70	375	4,25	1	102,00
0175 00 12	75	375	4,15	1	108,00
0175 00 13	80	400	6,10	1	138,00
0175 00 14	85	400	5,90	1	138,00
0175 00 15	90	445	8,35	1	183,00
0175 00 16	95	445	7,60	1	193,00
0175 00 17*	100	485	11,50	1	303,00
0175 00 18*	105	485	11,20	1	340,00
0175 00 19*	110	510	14,00	1	369,00
0175 00 20*	115	510	13,80	1	431,00
0175 00 21*	120	545	18,00	1	441,00
0175 00 22*	125	545	17,80	1	504,00
0175 00 23*	130	575	21,00	1	651,00
0175 00 24*	135	575	20,40	1	679,00
0175 00 25*	140	590	20,70	1	733,00
0175 00 26*	145	640	28,50	1	1.026,00
0175 00 27*	150	640	28,00	1	1.069,00
0175 00 28*	155	640	28,30	1	1.131,00
0175 00 29*	160	700	27,00	1	1.247,00
0175 00 30*	165	715	42,00	1	1.358,00
0175 00 31*	170	715	39,00	1	1.840,00
0175 00 32*	175	715	38,00	1	1.961,00
0175 00 33*	180	715	40,00	1	2.115,00

Schlag-Ringschlüssel Striking Face Ring Spanners



270

DIN 7444, Spezialstahl, gesandstrahlt, verzinkt für anhaltenden Rostschutz

For very heavy duty work, up to length 435mm Chrome-Vanadium steel 31CrV 3 (1.2208), above 480mm C35 steel, sand blasted, zinc plated

AF-Abmessungen auf Anfrage / AF-sizes on request

Art.-Nr. / No.	mm	mm	kg	VE	EUR
0270 00 01	24	165	0,20	1	17,30
0270 00 02	27	180	0,28	1	21,00
0270 00 03	30	190	0,38	1	25,00
0270 00 04	32	190	0,35	1	26,00
0270 00 05	36	210	0,50	1	33,00
0270 00 06	41	225	0,70	1	44,00
0270 00 07	46	240	0,98	1	47,00
0270 00 08	50	250	1,08	1	54,00
0270 00 09	55	270	1,32	1	60,00
0270 00 10	60	280	1,60	1	65,00
0270 00 11	65	290	2,30	1	84,00
0270 00 12	70	310	2,90	1	94,00
0270 00 13	75	325	2,60	1	99,00
0270 00 14	80	345	3,85	1	149,00
0270 00 15	85	365	3,55	1	179,00
0270 00 16	90	400	5,43	1	217,00
0270 00 17	95	400	4,90	1	244,00
0270 00 18*	100	400	6,80	1	276,00
0270 00 19*	105	420	6,30	1	312,00
0270 00 20*	110	440	7,96	1	356,00
0270 00 21*	115	440	7,90	1	389,00
0270 00 22*	120	470	9,90	1	619,00
0270 00 23*	125	470	9,10	1	797,00
0270 00 24*	130	510	13,30	1	869,00
0270 00 25*	135	525	12,50	1	906,00
0270 00 26*	140	550	13,70	1	1.054,00
0270 00 27*	145	550	18,25	1	1.381,00
0270 00 28*	150	550	18,75	1	1.474,00

* Auftragsbezogene Fertigung. Rücknahme ausgeschlossen.
* Manufacturing only on request. No return.

Art.-Nr. / No.	mm	mm	kg	VE	EUR
0280 00 20	22	180	0,40	1	28,00
0280 00 01	24	180	0,40	1	28,00
0280 00 02	27	190	0,42	1	28,00
0280 00 03	30	210	0,50	1	31,00
0280 00 04	32	234	0,70	1	32,00
0280 00 05	36	240	0,80	1	38,00
0280 00 06	41	250	0,95	1	45,00
0280 00 07	46	260	1,30	1	52,00
0280 00 08	50	267	1,45	1	59,00
0280 00 09	55	300	1,55	1	65,00
0280 00 10	60	345	2,30	1	83,00
0280 00 11	65	355	2,65	1	92,00
0280 00 12	70	365	3,00	1	105,00
0280 00 13	75	374	3,10	1	117,00
0280 00 14	80	384	4,00	1	135,00
0280 00 15	85	384	3,70	1	141,00
0280 00 16	90	410	5,10	1	260,00
0280 00 17	95	410	4,90	1	281,00
0280 00 18	100	410	4,80	1	299,00
0280 00 19	105	410	4,65	1	327,00
0280 00 24	22 – 30 7/8 – 1.3/16	460	600	1	23,00
0280 00 25	32 – 41 1.1/4 – 1.11/16	610	1130	1	27,00
0280 00 26	46 – 55 1.3/4 – 2.1/4	760	2200	1	48,00
0280 00 27	60 – 105 2.3/8 – 3"	860	2900	1	61,00

280

Zug-Ringschlüssel Heavy Duty Ring Spanners

Für höchste Beanspruchung, schwere Ausführung, gekröpft, Chrom-Vanadium-Stahl 31 CrV 3, voll galvanische Behandlung (vernickelt und verchromt), matt verchromt

Deep offset, for very heavy duty work, to use with club hammer or pneumatic hammer for tightening or loosening, Chrome-Vanadium steel 1.2208, hot forged, fully worked, sandblasted, zinc plated

AF-Abmessungen auf Anfrage / AF-sizes on request

Aufsteckrohre / Pipe bars



Art.-Nr. / No.	mm	g	VE	EUR	
0290 00 01	klein / small	110	25	5	1,20
0290 00 02	groß / big	110	30	5	1,60

290

Schlüsselhalter Holder for wrenches

Praktischer Schlüsselhalter aus Metall, mit 4 Aussparungen für Schlüssel, zum Befestigen an Werkbänken, Lochwänden, Arbeitstafeln usw., bringt Ordnung in Ihre Schlüsselsortimente, in zwei Größen für Schlüssel bis 14x15mm und bis 30x32mm

Holder for wrenches, metal plate, with 4 pockets for all kind of wrenches, for mounting on panels, workshop benches, display panels etc., get organized in your spanners assortment, in two sizes available for wrenches up to 14x15mm and up to 30x32mm



Zangen Pliers

Kraft-Kombinationszangen	Heavy Duty Combination Pliers
Rundzangen	Round Nose Pliers
Flachzangen	Flat Nose Pliers
Telefonzangen	Telephone Pliers
Seitenschneider	Side Cutting Nippers
Vornschnaider	End Cutting Nippers
Kabelschneider	Cable Cutter
Bolzenschneider	Bolt Cutter
Rabitzzangen	Tower Pincers
Kneifzangen	Carpenters Pincers
Elektronik-Spitzzangen	Electronic Nose Pliers
Elektronik-Seitenschneider	Electronic Side Cutters
Aderendhülsen-Zangen	Crimping Pliers for Cable Links
Abisolierzangen	Wire Stripping Pliers
Wasserpumpenzangen	Water Pump Pliers
Armaturen-Zangen	Plier Wrenches
Sicherungsring-Zangen	Circlip Pliers
Eckrohrzangen	Pipe Wrenches
Gripzangen	Grip Pliers
VDE-Zangen	VDE Pliers



Inhalt Index

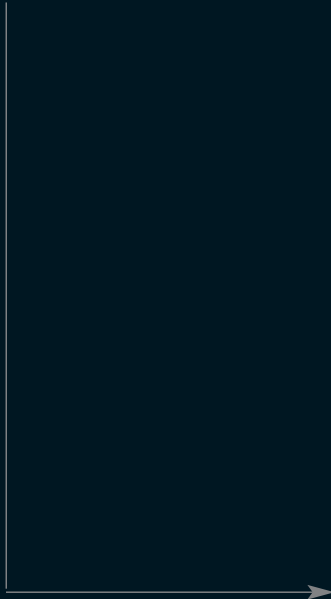

Zangen Pliers



Zangen / Pliers

Kraft-Kombinationszangen Heavy Duty Combination Pliers



500

DIN / ISO 5746, aus C-45 Vergütungsstahl, mit 2-Komponenten-Griff, für harten und weichen Draht, mit Hochfrequenz-gehärteter Präzisionsschneide, matt verchromt für langanhaltenden Rostschutz

DIN / ISO 5746, high grade tool steel C 45 (1.0503), with dual compound handle, for hard and soft wire, cutting edges induction hardened, matt chrome finish

Art.-Nr. / No.

mm " g VE EUR

Art.-Nr. / No.	mm	"	g	VE	EUR
0500 20 10	165	6.1/2	200	5	23,15
0500 20 20	180	7	270	5	24,35
0500 20 30	205	8	300	5	27,75

Integrierte Kabelaufnahme.
Integrated Cable Clamp.



Präzisionsprofil, induktionsgehärtet.
Precision profile, induction hardened.



Integrierter Kombi-Ringschlüssel.
Integrated ring spanner.



Langbeck-Rundzange Long Round Nose Plier



520

DIN / ISO 5745, aus C-45 Vergütungsstahl, mit 2-Komponenten-Griff, matt verchromt für langanhaltenden Rostschutz

DIN / ISO 5745, high grade tool steel C 45 (1.0503), with dual compound handle, matt chrome finish

Art.-Nr. / No.

mm " g VE EUR

Art.-Nr. / No.	mm	"	g	VE	EUR
0520 20 10	160	6.1/4	160	5	24,00

Langbeck-Flachzange Long Flat Nose Plier



525

DIN / ISO 5745, aus C-45 Vergütungsstahl, mit 2-Komponenten-Griff, matt verchromt für langanhaltenden Rostschutz

DIN / ISO 5745, high grade tool steel C 45 (1.0503), with dual compound handle, matt chrome finish

Art.-Nr. / No.

mm " g VE EUR

Art.-Nr. / No.	mm	"	g	VE	EUR
0525 20 10	160	6.1/4	185	5	23,50

Telefonzangen, gerade Telephone Pliers, straight



585

DIN / ISO 5745, lange, gerade, flachrunde Backen, mit Schneide und Brennerloch, gezahnte Greiffläche, für weichen und harten Draht, aus C-45 Vergütungsstahl, mit 2-Komponenten-Griff, matt verchromt für langanhaltenden Rostschutz

DIN / ISO 5745, long, straight, flat-round jaws, rod gripping hole and cutting edges, cut inside jaws, for soft and hard wire, high grade tool steel C 45 (1.0503), with dual compound handle, matt chrome finish

Art.-Nr. / No.

mm " g VE EUR

Art.-Nr. / No.	mm	"	g	VE	EUR
0585 20 10	170	6.3/4	170	5	23,00
0585 20 20	205	8	215	5	25,80

Art.-Nr. / No.	mm	"	g	VE	EUR	586
0586 20 10	205	8	215	5	28,15	<p>DIN / ISO 5745, lange, 45° abgewinkelte, flachrunde Backen, mit Schneide und Brennerloch, gezahnte Greiffläche, für weichen und harten Draht, aus C-45 Vergütungsstahl, mit 2-Komponenten-Griff, matt verchromt für langanhaltenden Rostschutz</p> <p>DIN / ISO 5745, long, 45° bent, flat-round jaws, rod gripping hole and cutting edges, cut inside jaws, for soft and hard wire, high grade tool steel C 45 (1.0503), with dual compound handle, matt chrome finish</p>

Telefonzange, gebogen

Telephone Plier, bent



Art.-Nr. / No.	mm	"	g	VE	EUR	532
0532 20 10	145	5.3/4	175	5	23,50	<p>DIN / ISO 5749, schwedische Form, aus C-45 Vergütungsstahl, mit 2-Komponenten-Griff, für harten und weichen Draht, matt verchromt für langanhaltenden Rostschutz</p> <p>DIN / ISO 5749, Swedish pattern, high grade tool steel C 45 (1.0503), with dual compound handle, for hard and soft wire, matt chrome finish</p>
0532 20 20	160	6.1/4	220	5	25,40	
0532 20 30	180	7	265	5	27,75	

Seitenschneider

Side Cutting Nippers



Extra langer Kopf für mehr Kraft.
Extra long head for more power,

Gefrästes Profil, kein Herausrutschen des Kabels.
Milled profile for perfect fixing of the cable.

Induktiv gehärtete Präzisionsschneide.
Precision cutting edges induction hardened.



Art.-Nr. / No.	g	EUR	500
0500 10 01	810	79,80	<p>Zangensortiment, 3-teilig, in Kartonsichtverpackung mit Kraft-Kombinationszange 180mm, Seitenschneider 180mm und Telefonzange, gerade 205mm</p> <p>Pliers Assortment 3-pcs., in display box with Combination Plier 180mm, Side Cutting Nipper 180mm and Telephone Plier, straight 205mm</p>
0500 10 02	810	83,00	<p>Zangensortiment, 3-teilig, in Kartonsichtverpackung wie oben jedoch mit Telefonzange, gebogen 205mm</p> <p>Pliers Assortment, 3-pcs., in display box as above with Telephone Plier, bent, 205mm</p>
0501 20 01	810	97,95	<p>VDE - Zangensortiment, 3-teilig, in Kartonsichtverpackung, wie oben mit gerader Telefonzange</p> <p>VDE - Pliers Assortment, 3-pcs., as above with Telephone Plier, straight, 205mm</p>
0501 20 02	810	99,95	<p>VDE - Zangensortiment, 3-teilig, in Kartonsichtverpackung, wie oben mit gebogener Telefonzange</p> <p>VDE - Pliers Assortment, 3-pcs., as above with Telephone Plier, bent, 205mm</p>

Zangensortiment, 3-tlg.

Pliers Assortment, 3-pcs.

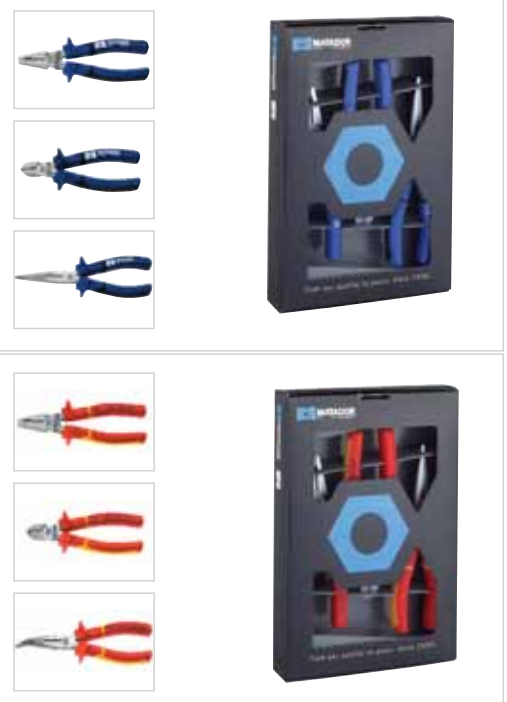

Zangen / Pliers

Kraft-Seitenschneider Heavy Duty Side Cutters



530

DIN / ISO 5749, für Piano-Draht, Leistungsklasse H, aus C-45 Vergütungsstahl, mit 2-Komponenten-Griff, matt verchromt für langanhaltenden Rostschutz

DIN / ISO 5749, for piano wire, high grade tool steel C 45 (1.0503), with dual compound handle, matt chrome finish

Art.-Nr. / No.	mm	"	g	VE	EUR
0530 20 10	180	7	280	5	27,75
0530 20 20	200	8	305	5	30,50
0530 20 30	240	9.1/2	420	5	41,00

Vornschneider End Cutting Nipper



535

DIN / ISO 5748, aus C-45 Vergütungsstahl, Leistungsklasse H, mit 2-Komponenten-Griff, für harten und weichen Draht, matt verchromt für langanhaltenden Rostschutz

DIN / ISO 5748, high grade tool steel C 45 (1.0503), with dual compound handle, for hard and soft wire, matt chrome finish

Art.-Nr. / No.	mm	"	g	VE	EUR
0535 20 10	160	6.1/4	255	5	27,00

Kabelschneider Cable Cutter



829

Kabelschneider, zum quetschfreien Abisolieren und Abschneiden von Kupfer- und Aluminiumkabeln bis Ø 16mm (50mm²), 11% leichteres Schneiden, nachstellbares Schraubgelenk, mit 2-Komponenten-Griff, matt verchromt für langanhaltenden Rostschutz

Cable Cutter, for stripping and cutting of copper and aluminium cables without any burr and up to Ø 16mm (50mm²), easier cutting by 11%, re-adjustable screw-joint, with dual compound handle, matt chrome finish

Art.-Nr. / No.	mm	"	g	VE	EUR
0829 00 01	160	6	175	5	34,90



Nachstellbares Schraubgelenk
Re-adjustable screw point

- Absolut quetschfreies Abisolieren von Kabeln
- Sauberer, gratfreier Schnitt durch spezielle Schneidengeometrie
- Reduzierter Kraftaufwand
- Erreicht absolut widerstandsarme elektrische Verbindungen

- Stripping and cutting of cables without any burr
- Perfect round cut of cables
- Less strain
- Electric junctions containing no resistance

Bolzenschneider Bolt Cutters



527

Bolzenabschneider für weichen Draht bis 785 N/mm² und harten Draht bis 1.226 N/mm², mit Stahlrohrschenkeln und PVC-Griffen, Temperguß

Bolt Cutters for soft (max. 785 N/mm²) and hard wire (max. 1.226 N/mm²), with tubular steel handles and plastic grips, annealed cast iron

Art.-Nr. / No.	mm	"	g	VE	EUR
0527 00 01	7 - 460	18	1,7	1	89,90
0527 00 02	8 - 610	24	2,5	1	129,00
0527 00 03	9 - 780	30	4,7	1	173,90
0527 00 04	10 - 900	36	5,1	1	228,90

Ersatzköpfe / Spare heads:

0527 00 11	für / for 0527 00 01	1	50,50
0527 00 12	für / for 0527 00 02	1	62,85
0527 00 13	für / for 0527 00 03	1	96,50
0527 00 14	für / for 0527 00 04	1	109,90

Art.-Nr. / No.	↔		g	VE	EUR	544
	mm	"				
0544 00 01	220	9	330	5	17,60	<p>DIN / ISO 9242 Form A, aus C-45 Vergütungsstahl, für Arbeiten z. B. an der Karosserie, schwarz mit blankem Kopf</p> <p>According to DIN / ISO 9242, Form A, high grade tool steel C 45 (1.0503), for car body work, long leverage, black finish with polished head</p>
0544 00 02	250	10	460	5	20,40	

Rabitzzangen Tower Pincers



Art.-Nr. / No.	↔		g	VE	EUR	545
	mm	"				
0545 00 03	200	8	400	5	15,80	<p>DIN / ISO 9243 Form A, aus C-45 Vergütungsstahl, schwarz mit blankem Kopf</p> <p>DIN / ISO 9243, Form A, high grade tool steel C 45 (1.0503), black finish with polished head</p>

Kneifzangen Carpenters Pincers



Art.-Nr. / No.	↔		g	VE	EUR	560
	mm	"				
0560 00 01	120	4.3/4	54	5	18,50	<p>Elektrostatisch ableitend, glatte Innenflächen, Kanten gerundet, zum Greifen feiner Teile und Formen von Drähten, eingelegtes Präzisionsgelenk, Ölhartestahl gesenkgeschmiedet, induktiv gehärtete Schneiden, poliert, mit ESD-2-Komponenten-Griffen</p> <p>Electrostatic bleed off, smooth inside jaws, edges rounded, for gripping small items and forming wires, lap-joint version, oil-hardened steel, drop forged, cutting edges additionally hardened, polished, with ergonomically ESD-2-components handles</p>

Elektronik-Spitzzange ESD Electronic Nose Plier



Art.-Nr. / No.	↔		g	VE	EUR	561
	mm	"				
0561 00 01	120	4.3/4	50	5	21,00	<p>Elektrostatisch ableitend, gebräuchlichste Form für Arbeiten an Leiterplatten, in Gehäusen und im Telefonbau, eingelegtes Präzisionsgelenk, Ölhartestahl gesenkgeschmiedet, induktiv gehärtete Schneiden, poliert, mit ESD-2-Komponenten-Griffen</p> <p>Electrostatic bleed off, most popular shape for assembly work, trimming printed circuit boards, also for radio and telephone work, lap-joint version, oil-hardened steel, drop forged, cutting edges additionally hardened, with ESD-2-components handles</p>

Elektronik-Seitenschneider ESD Electronic Side Cutter



Art.-Nr. / No.	↔		g	VE	EUR	572
	mm	"				
0572 00 10	190	7.1/2	250	1	24,10	<p>Für Aderendhülsen nach DIN 46228, Ölhartestahl, handgeschmiedet, für unisolierte und isolierte Aderendhülsen (0,5 - 16 mm²), Hebelübersetzung für leichteres Arbeiten, tauchisolierte Griffe</p> <p>For End-sleeves according to DIN 46228, Tool steel, drop-forged, for non-insulated and insulated end-sleeves (0,5 - 16mm²), improved leverage for easier working, PVC-coated handles</p>

Aderendhülsen-Zangen Crimping Pliers for Cable Links



Zangen / Pliers

Vollautomatische Abisolierzange Fully automatic wire stripping plier



575

Abisolierzange mit automatischer Einstellung auf den Querschnitt des Leiters, für PVC-isolierte massive und flexible Kabel, Bereich 0,5 - 4,0mm², integrierter Seitenschneider für das Abschneiden von Drähten, im Kunststoff-Gehäuse

Wire Stripping Plier with fully automatic adjustment between 0.5-4.0mm², fully insulated, integrated side cutting nipper, in black plastic housing

Art.-Nr. / No.

mm

g VE

EUR

0575 00 01

180

100 1

33,50

Abisolier-Zange Wire stripping Plier



576

Abisolierzange mit Einstellschraube, selbstöffnend, für Drähte bis 6mm ø, aus C-45 Vergütungsstahl, mit 2-Komponenten-Griff, matt verchromt für langanhaltenden Rostschutz (nicht nur poliert)

Wire Stripping Plier, spring loaded, with locking adjustable screw for setting, for wires up to 6mm ø, high grade tool steel C 45 (1.0503), with dual compound handle, for hard and soft wire, matt chrome finish (not only polished)

Art.-Nr. / No.

mm

"

g VE

EUR

0576 20 10

160

6.1/4

170 5

24,30

Wasserpumpenzange Water Pump Plier



554

DIN / ISO 8976 Form A, Schenkel tauchisoliert, Chrom-Vanadium-Stahl 31 CrV 3, voll galvanische Behandlung (vernickelt und verchromt), matt verchromt

DIN / ISO 8976 Form A, PVC-coated, Chrome-Vanadium-Steel 31 CrV 3 (1.2208), full galvanic treatment (nickel and chromium plated), matt chrome finish

Art.-Nr. / No.

mm

"

g VE

EUR

0554 00 01

240

9.1/2

280 10

19,00

Wasserpumpenzange Water Pump Plier



556

DIN / ISO 8976 Form C, mit durchgestecktem Gewerbe und Klemmschutz, Schenkel tauchisoliert, Chrom-Vanadium-Stahl 31 CrV 3, brüniert

DIN / ISO 8976 Form C, box joint, PVC-coated, Chrome-Vanadium-Steel 31 CrV 3 (1.2208), black finish

Art.-Nr. / No.

mm

"

g VE

EUR

0556 00 03

180

7

155 10

16,25

0556 00 01

240

9.1/2

325 10

21,85

0556 00 02

300

12

325 10

43,00

Zangensortiment, 3-tlg. Pliers Assortment, 3-pcs.

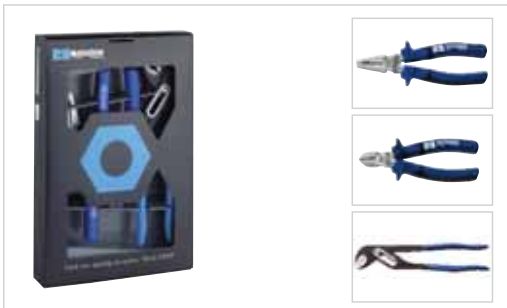

556

Zangensortiment, 3-teilig in Sichtverpackung mit
- Kraft-Kombinationszange 180mm
- Kraft-Seitenschneider 180mm
- Wasserpumpenzange 240mm

Pliers Assortment 3-pcs. in display box with
- Combination Plier 180mm
- Heavy Duty Side Cutter 180mm
- Water Pump Plier 240

Art.-Nr. / No.

g

EUR

0556 20 01





970

75,00

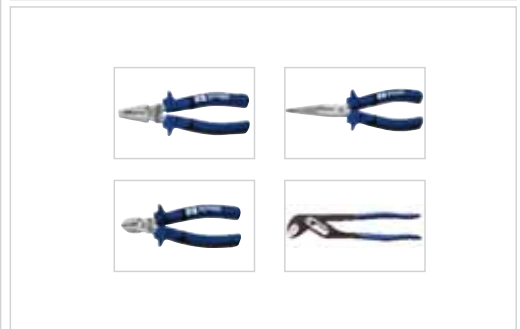
Art.-Nr. / No.	 g	EUR	556
0556 20 11	1270	99,00	<p>Zangensortiment, 4-teilig, in Kartonsichtverpackung mit</p> <ul style="list-style-type: none"> - Kraft-Kombinationszange 180mm, - Seitenschneider 180mm, - Telefonzange, gerade 205mm - Wasserpumpenzange 240mm <p>Pliers Assortment 4-pcs., in display box with</p> <ul style="list-style-type: none"> - Combination Plier 180mm, - Side Cutting Nipper 180mm - Telephone Plier, straight 205mm - Water Pump Plier 240mm
0556 20 12	1270	99,00	

Zangensortiment, 4-tlg. Pliers Assortment, 4-pcs.



Art.-Nr. / No.	 mm	 "	 g	 VE	EUR	557
0557 00 01	250	9.1/2	380	5	28,35	<p>DIN / ISO 8976, Druckknopf-Einhand-Verstellung, doppelt verzahnte Greifbacken, Klemmschutz bei jeder Einstellung, mit durchgestecktem Sicherheitsgewerbe, Schenkel tauchisoliert, Chrom-Vanadium-Stahl 31 CrV 3</p> <p>DIN / ISO 8976, quick precise adjustment and release with one hand, inverse box joint, safety protection of fingers, cogs additionally induction hardened, PVC-coated, Chrome-Vanadium-Steel 31 CrV 3 (1.2208)</p>
0557 00 02	400	12	530	5	46,45	

Wasserpumpenzange, Profi Water Pump Plier, Profi



Greifbacken doppelt verzahnt, Greifzähne zusätzlich induktiv gehärtet.

Dual toothed (serrated) jaws, additional induction hardened cogs.

Druckknopf mit 4-Zahntechnik für optimalen Halt auf der Rastverzahnung.

Press-button with 4 teeth technic for optimum grip.

Klemmschutz für sicheres Arbeiten in jeder Position.
Safety protection in every position.

Maximale Maulöffnung 40% über DIN ISO.
Maximum jaw opening 40% over DIN ISO.

Neue Form: Mehr Biß, mehr Spannweite, mehr Sicherheit.

New design: More grip, more jaw opening, more safety.

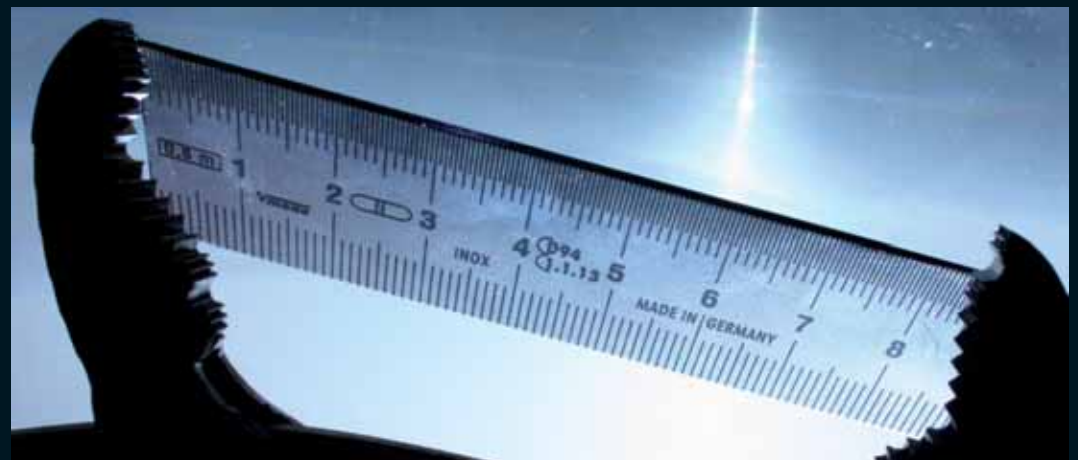

Zangen / Pliers

Spezial-Montagezange Special Mounting Plier



558

Armaturen-Zangenschlüssel, Anziehen und Lösen nach dem Ratschenprinzip, mit durchgestecktem Gleitgelenk, bewegliche Backen, Druckknopf-Schnellverstellung, Einstellskala 12-53mm, Schenkel tauchisoliert, Chrom-Vanadium-Stahl 31 CrV 3, voll galvanische Behandlung, matt verchromt

Plier Wrench, box joint, jaws moveable with parallel grip, quick one hand use, scale 12-53mm, PVC-coated handles, Chrome-Vanadium-Steel 31 CrV 3 (1.2208), full galvanic treatment, matt chrome finish

Art.-Nr. / No. mm " g VE EUR

0558 00 01	250	20/36	375	5	39,95
------------	-----	-------	-----	---	-------

Spezial-Montagezange Special Mounting Plier



540

Zum Montieren von hufeisenförmigen Sprengringen und Sicherheitsringen ohne Greiflöcher für Wellensicherungen jeder Art, mit Öffnungsfeder, Werkzeugstahl, gesenkgeschmiedet, voll galvanische Behandlung (vernickelt und verchromt), matt verchromt

For mounting horseshoe-shaped circlips without hole for shaft safety devices of any kind, with opening spring, for hard and soft wires, tool steel, full galvanic treatment, matt chrome finish

Art.-Nr. / No. mm " g VE EUR

0540 00 01	180	7.1/4	175	5	32,45
------------	-----	-------	-----	---	-------

Zangen für Sicherungsringe, A Circlip Pliers, A



578

DIN 5254 Form A, für Außensicherungsringe (Welle) nach DIN 471 und 983, gerade Ausführung, mit Rückstellfeder, Schenkel tauchisoliert, leicht, Chrom-Vanadium-Stahl 31 CrV 3, voll galvanische Behandlung (vernickelt und verchromt), matt verchromt

DIN 5254 Form A, for external circlips according to DIN 471 and DIN 983, straight, readjusting spring, PVC-coated, Chrome-Vanadium-Steel 31 CrV 3 (1.2208), full galvanic treatment (nickel and chromium plated), matt chrome finish

Art.-Nr. / No. mm mm g VE EUR

0578 00 01	A0	140	3-10	95	5	19,00
0578 00 02	A1	140	10-25	100	5	17,90
0578 00 03	A2	180	19-60	160	5	19,50
0578 00 04	A3	225	40-100	240	5	23,65
0578 00 05	A4	310	85-165	500	5	37,70

Zangen für Sicherungsringe, B Circlip Pliers, B



580

DIN 5254 Form B, für Außensicherungsringe (Welle) nach DIN 471 und 983, gebogene Ausführung, mit Rückstellfeder, Schenkel tauchisoliert, leicht, Chrom-Vanadium-Stahl 31 CrV 3, voll galvanische Behandlung (vernickelt und verchromt), matt verchromt

DIN 5254 Form B, for external circlips according to DIN 471 and DIN 983, bent, readjusting spring, PVC-coated, Chrome-Vanadium-Steel 31 CrV 3 (1.2208), full galvanic treatment (nickel and chromium plated), matt chrome finish

Art.-Nr. / No. mm mm g VE EUR

0580 00 01	A01	130	3-10	100	5	19,85
0580 00 02	A11	130	10-25	100	5	18,80
0580 00 03	A21	165	19-60	155	5	20,40
0580 00 04	A31	215	40-100	250	5	25,10
0580 00 05	A41	300	85-165	515	5	38,70

Zangen für Sicherungsringe, C Circlip Pliers, C



582

DIN 5254 Form C, für Innensicherungsringe (Bohrung) nach DIN 472 und 984, gerade Ausführung, mit Rückstellfeder, Schenkel tauchisoliert, leicht, Chrom-Vanadium-Stahl 31 CrV 3, voll galvanische Behandlung (vernickelt und verchromt), matt verchromt

DIN 5254 Form C, for internal circlips according to DIN 472 and DIN 984, straight, readjusting spring, PVC-coated, Chrome-Vanadium-Steel 31 CrV 3 (1.2208), full galvanic treatment (nickel and chromium plated), matt chrome finish

Art.-Nr. / No. mm mm g VE EUR

0582 00 01	J1	140	8-25	85	5	14,85
0582 00 02	J2	180	19-60	145	5	16,25
0582 00 03	J3	225	40-100	220	5	21,05
0582 00 04	J4	315	85-165	365	5	34,45

Art.-Nr. / No.	↔		g	VE	EUR	584
	mm	mm				
0584 00 01	J11	130	8-25	80	5	15,70
0584 00 02	J21	165	19-60	145	5	16,95
0584 00 03	J31	210	40-100	220	5	21,85
0584 00 04	J41	295	85-165	480	5	36,00

DIN 5254 Form D, für Innensicherungsringe (Bohrung) nach DIN 472 und 984, gebogene Ausführung, mit Rückstellfeder, Schenkel tauchisoliert, leicht, Chrom-Vanadium-Stahl 31 CrV 3, voll galvanische Behandlung, matt verchromt

DIN 5254 Form D, for internal circlips according to DIN 472 and DIN 984, bent, readjusting spring, PVC-coated, Chrome-Vanadium-Steel 31 CrV 3 (1.2208), full galvanic treatment (nickel and chromium plated), matt chrome finish

Zangen für Sicherungsringe, D Circlip Pliers, D

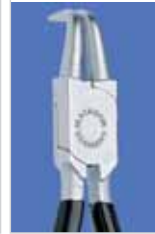

Art.-Nr. / No.	↔		g	EUR	578
	mm	mm			
0578 0050			700	79,00	

Sicherungsringzangen-Sortiment, 4-teilig, in Kartonsichtverpackung mit folgenden Typen:

- außen, gerade, 180mm, A2
- außen, gebogen, 165mm, A21
- innen, gerade, 180mm, J2
- innen, gebogen, 165mm, J21

Assortment of Circlip Pliers, 4-pcs., in display box with the following types:

- outside, straight, 180mm, A2
- outside, bent, 165mm, A21
- inside, straight, 180mm, J2
- inside, bent, 165mm, J21

Sortiment Sicherungsringzangen Assortment Circlip Pliers



Art.-Nr. / No.	↔		g	VE	EUR	596
	"	mm				
0596 00 01	1/2	240	425	1	44,00	
0596 00 02	1	320	935	1	47,00	
0596 00 03	1.1/2	400	1500	1	55,30	
0596 00 04	2	560	2725	1	90,00	
0596 00 05	3	630	3400	1	166,00	

DIN 5234 Form C (S-Maul), gesenkgeschmiedet, induktive Zahnhärtung, optimal für runde Werkstücke, mit Selbstklemmeffekt durch zwei Prismen im Maul, ermöglichen ein Greifen nahezu aller runder Werkstücke mit 3-Punkt-Anlage, rot lackiert

DIN 5234 Form C, S-shaped, completely forged, induction-hardened gripping surface, with reinforced sleeve, self-grip function on the workpiece, lacquered

Eckrohrzangen "S-Maul" Pipe Wrenches "S shaped"



Art.-Nr. / No.	↔		g	VE	EUR	597
	"	mm				
0597 00 01	1	310	970	1	40,70	
0597 00 02	1.1/2	430	1690	1	56,00	
0597 00 03	2	540	2880	1	95,60	
0597 00 04	3	630	4120	1	149,00	

DIN 5234 Form A (schwedisches Modell), gesenkgeschmiedet, induktive Zahnhärtung, perfektes Greifen flacher Werkstücke, Muttern oder anderer Verschraubungen mit parallelliegenden Spannflächen, ermöglichen ein Greifen mit 2-Punkt-Anlage, rot lackiert

DIN 5234 Form A, Swedish pattern, completely forged, induction-hardened gripping surface, with reinforced sleeve, self-grip function on the workpiece, lacquered

Eckrohrzangen 90° Pipe Wrenches 90°



Zangen / Pliers

Tischklammer für Gripzangen Desk clamp plier



589

Zum Einstecken von Gripzangen, als Schraubstock verwendbar für leichte Arbeiten, ideal für Werkbänke, Arbeitstische, mobilen Einsatz etc.

Desk clamp plier for fixing grip pliers, converts them into a versatile portable vice, ensures firm hold on all work pieces, usable as a normal C-Clamp or combinable with locking tools for hands free work in the workshop, at home or in the field

Art.-Nr. / No.	mm	"	g	VE	EUR
0589 00 90	110		390	1	9,95

Der Mini-Schraubstock von MATADOR:
The mini bench-vice from MATADOR:



Abklemm-Gripzange Grip Plier for squeezing



587

Für Rohre, dient als Verschlussventil beim Verlöten von Kupferrohren, große Klemmkraft. Spannweite 0-6mm, mit Schnelllösehebel und Stellschraube, geschmiedete Backen aus CV-Stahl, Zangenkörper aus hochfestem Federstahl, vernickelt

For squeezing copper pipes during solder works, jaw opening 0-6mm, with quick-release lever and adjusting screw, jaws forged and made of CV-steel, pliers body made of special steel, nickel plated

Art.-Nr. / No.	mm	"	g	VE	EUR
0587 00 02	190		390	1	26,95



Universal-Gripzangen Grip Pliers - curved jaw



588

Mit halbrunden Backen und Drahtschneider, mit Schnelllösehebel und Stellschraube, geschmiedete Backen aus Chrom-Vanadium-Stahl, Zangenkörper aus hochfestem Federstahl, vernickelt

With halfround jaws and wire cutter, with quick-release lever and adjusting screw, jaws forged and made of Chrome Vanadium-steel, pliers body made of special steel, nickel plated

Art.-Nr. / No.	mm	"	g	VE	EUR
0588 00 01	175	7	380	1	21,95
0588 00 02	250	10	560	1	23,54
0588 00 03	300	12	925	1	38,70

Ideal-Gripzangen Ideal Grip Pliers - curved jaw



588

Mit Spezial-Backen, kombinierte Maulform für rundes, flaches, eckiges und profiliertes Material, mit Schnelllösehebel und Stellschraube, geschmiedete Backen aus CV-Stahl, Zangenkörper aus hochfestem Federstahl, vernickelt

With combined shape of jaws, suitable for round, flat, square and shaped materials, with quick-release lever and adjusting screw, jaws forged and made of Chrome Vanadium-steel, pliers body made of special steel, nickel plated

Art.-Nr. / No.	mm	"	g	VE	EUR
0588 00 09	250	10	510	1	24,00

Art.-Nr. / No.	mm	"	g	VE	EUR	588
0588 00 04	180	7.1/4	280	1	19,75	<p>Mit einer geraden Backe und einer Backe mit Prismenaussparung, Maulform für rundes und flaches Material, mit Schnelllösehebel und Stellschraube, geschmiedete Backen aus CV-Stahl, Zangenkörper aus hochfestem Federstahl, vernickelt</p> <p>With longwise groove in the top jaw, suitable for round and flat materials, with quick-release lever and adjusting screw, jaws forged and made of Chrome Vanadium-steel, pliers body made of special steel, nickel plated</p>
0588 00 05	250	10	490	1	21,30	
0588 00 06	300	12	750	1	35,20	

Prisma-Gripzangen

Prisma-Grip Pliers - straight jaw



Art.-Nr. / No.	mm	g	VE	EUR	587
0587 00 01	95	120	1	22,20	<p>Für enge Platzverhältnisse, auch als Masse beim Schweißen einsetzbar, nur 95mm lang, Spannbereich 0-11mm, geradlinige Führung der beweglichen Backe, Einhandbedienung, Messingschraube zur Feineinstellung, hochwertige Aluminium-Legierung, funkenfrei</p> <p>Only 95mm long, straight motion of the mobile jaw, jaw opening 0-11mm, enables one hand operation, adjusting screw made of brass, high-quality, heat treated aluminium alloy steel.</p>

Miniatur-Abklemm-Gripzange

Micro Pliers



Art.-Nr. / No.	mm	g	VE	EUR	587
0587 00 04	240	410	1	42,75	<p>Für Arbeiten an besonders schwer zugänglichen Stellen, z. B. Anpassen von Türen, Heckklappen und Motorhauben, ohne die Zange zu entfernen, Einhandbedienung, Schnell-Lösehebel, hält zwei überlappende Bleche, Spannweite 0-18mm, Backenbreite 18mm, Spezialstahl, glanzvernickelt</p> <p>For gripping two lap joints, when fitting motorcar parts the adjustment of doors, tailgates and engine bonnets can be completed without removing the pliers, jaw opening 0-18mm, jaw width 18mm</p>

Axial-Gripzange Typ L

Axial Grip Plier, Type L



Art.-Nr. / No.	mm	"	g	VE	EUR	589
0589 00 03	275	11	700	1	35,20	<p>Besonders geeignet für sperrige Werkstücke oder Profile mit hohen Stegen, als Schraubzwinde einsetzbar, mit beweglichen Stahlbacken, Spanntiefe: 0 - 70mm, Spannbereich: 0 - 90mm, geschmiedete Backen aus Chrom-Vanadium-Stahl, Zangenkörper aus hochfestem Federstahl, vernickelt</p> <p>Ideal for bulky workpieces and profiles with high crosspieces, with movable jaws, clamping reach: 10-70 / 0-90mm, jaws forged and made of Chrome Vanadium-steel, nickel plated</p>

Klammer-Gripzange

C-Clamp Grip Plier



Art.-Nr. / No.	mm	"	g	VE	EUR	589
0589 00 02	280	11	800	1	33,60	<p>Besonders geeignet für Röhre, breiter Schnell-Lösehebel, Spannbereich: 0 - 90mm, geschmiedete Backen aus Chrom-Vanadium-Stahl, Zangenkörper aus hochfestem Federstahl, vernickelt</p> <p>Especially for tubes, clamping reach 0-90mm, jaws forged and made of Chrome Vanadium-steel, nickel plated</p>

Rohr-Schweißer-Gripzange

Tube Welding Grip Plier



VDE-Zangen / VDE-Pliers

Kraft-Kombinationszangen Heavy Duty Combination Pliers



500 VDE

DIN / ISO 5746, aus C-45 Vergütungsstahl, mit 2-Komponenten-Griff, für harten und weichen Draht, matt verchromt für langanhaltenden Rostschutz (nicht nur poliert)

DIN / ISO 5746, high grade tool steel C 45 (1.0503), with dual compound handle, for hard and soft wire, matt chrome finish (not only polished)

Art.-Nr. / No.	mm		"		g	VE	EUR
	mm	mm	"	"			
0500 20 40	165	6.1/2	200	8	5	28,25	
0500 20 50	180	7	255	8	5	30,00	
0500 20 60	205	8	280	8	5	33,30	

Langbeck-Rundzange Long Round Nose Plier



520 VDE

DIN / ISO 5745, aus C-45 Vergütungsstahl, mit 2-Komponenten-Griff, matt verchromt für langanhaltenden Rostschutz (nicht nur poliert)

DIN / ISO 5745, high grade tool steel C 45 (1.0503), with dual compound handle, matt chrome finish (not only polished)

Art.-Nr. / No.	mm		"		g	VE	EUR
	mm	mm	"	"			
0520 20 20	160	6.1/4	165	6.5/8	5	29,10	

Langbeck-Flachzange Long Flat Nose Plier



525 VDE

DIN / ISO 5745, aus C-45 Vergütungsstahl, mit 2-Komponenten-Griff, matt verchromt für langanhaltenden Rostschutz (nicht nur poliert)

DIN / ISO 5745, high grade tool steel C 45 (1.0503), with dual compound handle, matt chrome finish (not only polished)

Art.-Nr. / No.	mm		"		g	VE	EUR
	mm	mm	"	"			
0525 20 20	160	6.1/4	175	6.7/8	5	30,40	

Seitenschneider Side Cutting Nippers



532 VDE

DIN / ISO 5749, schwedische Form, aus C-45 Vergütungsstahl, mit 2-Komponenten-Griff, für harten und weichen Draht, matt verchromt für langanhaltenden Rostschutz

DIN / ISO 5749, Swedish pattern, high grade tool steel C 45 (1.0503), with dual compound handle, for hard and soft wire, matt chrome finish

Art.-Nr. / No.	mm		"		g	VE	EUR
	mm	mm	"	"			
0532 20 40	160	6.1/4	220	8.5/8	5	31,65	
0532 20 50	180	7	255	8.5/8	5	34,35	

Kabelschneider Cable Cutter



829 VDE

Zum quetschfreien Abisolieren und Abschneiden von Kupfer- und Aluminiumkabeln bis Ø 16mm (50mm²), 11% leichteres Schneiden, nachstellbares Schraubgelenk, mit 2-Komponenten-Griff, matt verchromt für langanhaltenden Rostschutz

For stripping and cutting of copper and aluminium cables without any burr and up to Ø 16mm (50mm²), easier cutting by 11%, re-adjustable screw-joint, with dual compound handle, matt chrome finish

Art.-Nr. / No.	mm		"		g	VE	EUR
	mm	mm	"	"			
0829 00 02	160	6	225	8.7/8	5	39,30	

Art.-Nr. / No.	↔		g	VE	EUR	576 VDE
	mm	"				
0576 20 20	160	6.1/4	188	5	32,90	Abisolierzange mit Einstellschraube, selbstöffnend, für Drähte bis 6mm ø, aus C-45 Vergütungsstahl, mit 2-Komponenten-Griff, matt verchromt für langanhaltenden Rostschutz Wire Stripping Plier, spring loaded, with locking adjustable screw for setting, for wires up to 6mm ø, high grade tool steel C 45 (1.0503), with dual compound handle, for hard and soft wire, matt chrome finish

Abisolier-Zangen Wire stripping Pliers



Art.-Nr. / No.	↔		g	VE	EUR	585 VDE
	mm	"				
0585 20 30	170	6.3/4	165	5	30,00	DIN / ISO 5745, lange, gerade, flachrunde Backen, mit Schneide und Brennerloch, gezahnte Greiffläche, für weichen und harten Draht, aus C-45 Vergütungsstahl, mit 2-Komponenten-Griff, matt verchromt für langanhaltenden Rostschutz DIN / ISO 5745, long, straight, flat-round jaws, rod gripping hole and cutting edges, cut inside jaws, for soft and hard wire, high grade tool steel C 45 (1.0503), with dual compound handle, matt chrome finish
0585 20 40	205	8	215	5	33,50	

Telefonzange, gerade Telephone Plier, straight



Art.-Nr. / No.	↔		g	VE	EUR	586 VDE
	mm	"				
0586 20 20	205	8	215	5	35,90	DIN / ISO 5745, lange, 45° abgewinkelte, flachrunde Backen, mit Schneide und Brennerloch, gezahnte Greiffläche, für weichen und harten Draht, aus C-45 Vergütungsstahl, mit 2-Komponenten-Griff, matt verchromt für langanhaltenden Rostschutz DIN / ISO 5745, long, 45° bent, flat-round jaws, rod gripping hole and cutting edges, cut inside jaws, for soft and hard wire, high grade tool steel C 45 (1.0503), with dual compound handle, matt chrome finish

Telefonzange, gebogen Telephone Plier, bent



Art.-Nr. / No.	⚖		EUR	501 VDE
	g			
0501 20 01	810		94,95	Zangensortiment, 3-teilig, in Kartonsichtverpackung mit - Kraft-Kombinationszange 180mm - Seitenschneider 180mm - Telefonzange gerade 205mm Pliers Assortment 3-pcs. in display box with - Combination Plier 180mm - Side Cutting nippers 180mm - Telephone Plier straight 205mm
Mit gebogener Telefonzange / with telephone plier bent				
0501 20 02	810		94,95	Zangensortiment, 3-teilig, in Kartonsichtverpackung wie oben jedoch mit Telefonzange gebogen 205mm Pliers Assortment 3-pcs., in display box as above but with Telephone Plier bent 205mm

Zangensortiment, 3-tlg. Pliers Assortment, 3-pcs.



Winkelschraubendreher	Key Wrenches
Schraubendreher	Screwdrivers
Bits	Bits

Winkelschraubendreher	Hexagon Key Wrenches
TORX-Winkelschraubendreher	TORX Key Wrenches
T-Griff-Winkelschraubendreher	T-Handle Key Wrenches
Holzheft-Schraubendreher	Screwdrivers with wooden handle
Werkstattschraubendreher	Workshop Screwdrivers
Umsteckbare Schraubendreher	Reversible Blade Screwdrivers
Spannungsprüfer	Voltage Testers
VDE-Schraubendreher	VDE-Screwdrivers
Elektroniker-Schraubendreher	Precision Screwdrivers
Extra lange Schraubendreher	Long type Screwdrivers
5-Stern-Schraubendreher	Screwdrivers with 5-star profile
Autolichtprüfer	Car Light Tester
Vergaser-Schraubendreher	Carburettor Screwdrivers
Schlag-Schraubendreher	Impact Screwdrivers
Verbindungsteile	Hex Power Shanks / Adaptors
Bits	Bits
TIN-Bits	TIN-Bits
MTS-Bit Sortimente	MTS-Bit Assortments



Inhalt Index

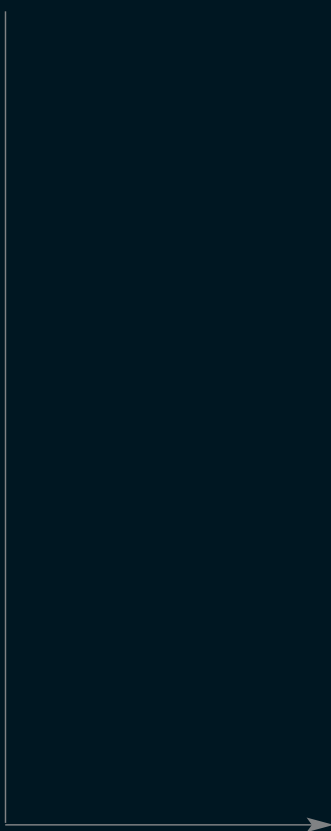

Schraubendreher Screwdrivers

Winkelschraubendreher / Allen Keys

Winkelschraubendreher Hexagon Key Wrenches

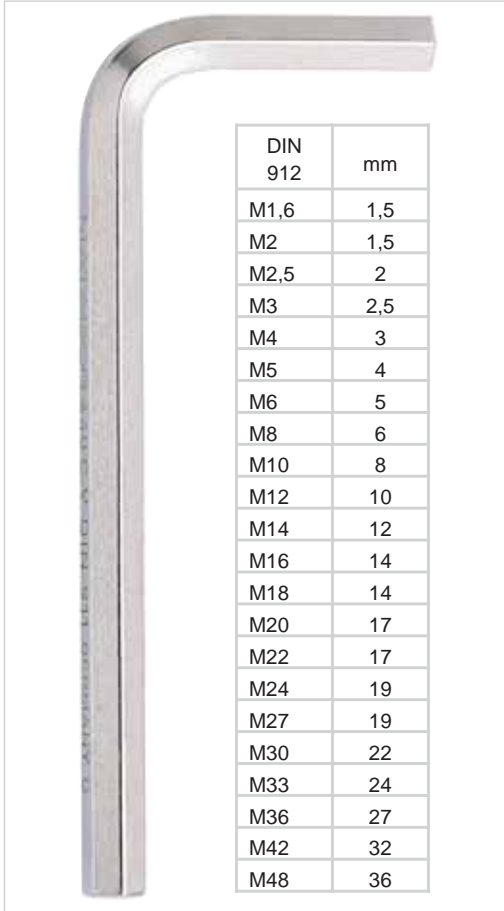

440

6-kant-Winkelschraubendreher, für Innensechskant-Schrauben nach DIN 912, DIN 911 / ISO 2936, gefast, Chrom-Vanadium-Stahl 59 CrMo 4, vernickelt

Hexagon Key Wrenches, for hexagon head screws according to DIN 912, DIN 911 / ISO 2936, chamfered, Chrome-Vanadium-Steel 59 CrMo 4 (1.2243), nickel plated

Art.-Nr. / No.	AF	mm	g	VE	EUR
0440 01 01	1/16	45 x 12	2	10	0,25
0440 01 02	5/64	48 x 15	2	10	0,25
0440 01 03	3/32	51 x 18	4	10	0,30
0440 01 04	1/8	57 x 20	5	10	0,45
0440 01 05	5/32	64 x 25	11	10	0,50
0440 01 06	3/16	70 x 28	20	10	0,65
0440 01 07	7/32	76 x 32	30	10	0,75
0440 01 08	1/4	83 x 34	45	10	0,82
0440 01 09	5/16	95 x 36	60	10	1,40
0440 01 10	3/8	108 x 38	80	10	2,00
0440 01 11	7/16	116 x 40	105	10	2,45
0440 01 12	1/2	134 x 42	135	10	3,35
0440 01 13	9/16	146 x 45	170	5	4,35
0440 01 14	5/8	159 x 55	265	5	6,80
0440 01 15	3/4	180 x 60	445	5	9,25

Art.-Nr. / No.	mm	mm	g	VE	EUR
0440 00 01	1,5	45 x 12	2	10	0,25
0440 00 02	2	50 x 15	2	10	0,25
0440 00 03	2,5	55 x 18	4	10	0,25
0440 00 04	3	62 x 20	5	10	0,30
0440 00 36	3,5	65 x 25	8	10	0,40
0440 00 05	4	67 x 25	11	10	0,45
0440 00 37	4,5	75 x 31	15	10	0,60
0440 00 06	5	78 x 28	20	10	0,60
0440 00 38	5,5	85 x 30	25	10	0,65
0440 00 07	6	88 x 32	30	10	0,80
0440 00 08	7	96 x 34	45	10	1,05
0440 00 09	8	96 x 36	60	10	1,35
0440 00 10	9	100 x 38	80	10	1,75
0440 00 11	10	108 x 40	105	10	1,85
0440 00 12	11	114 x 42	135	10	2,40
0440 00 13	12	118 x 45	170	5	2,90
0440 00 14	14	135 x 55	265	5	3,95
0440 00 15	17	158 x 60	445	5	7,15
0440 00 16	19	170 x 70	620	5	8,50
0440 00 17	22	195 x 80	950	5	13,85
0440 00 31	24	215 x 90	1250	1	21,10
0440 00 32	27	240 x 100	1770	1	30,50
0440 00 33	30	280 x 112	2460	1	45,50
0440 00 34	32	305 x 125	3140	1	63,50
0440 00 35	36	350 x 140	4400	1	82,00



Winkelschraubendreher Hexagon Key Wrenches



440

Satz 6-kant-Winkelschraubendreher am Ring, für Innensechskant-Schrauben nach DIN 912, DIN 911 / ISO 2936, gefast, Chrom-Vanadium-Stahl 59 CrMo 4, vernickelt

Set of Hexagon Key Wrenches, on ring, for hexagon head screws according to DIN 912, DIN 911 / ISO 2936, chamfered, Chrome-Vanadium-Steel 59 CrMo 4 (1.2243), nickel plated

Art.-Nr. / No.	g	VE	EUR
6-tlg. / pcs.: 2 / 2,5 / 3 / 4 / 5 / 6mm 0440 00 22	320	5	7,50
10-tlg. / pcs.: 1,5 / 2 / 2,5 / 3 / 3,5 / 4 / 5 / 6 / 8 / 10mm 0440 00 20	320	5	8,50
10-tlg. / pcs.: 1/16 - 5/64 - 3/32 - 1/8 - 5/32 - 3/16 - 7/32 1/4 - 5/16 - 3/8" AF 0440 01 18	280	5	8,50

Winkelschraubendreher Hexagon Key Wrenches





440

Satz 6-kant-Winkelschraubendreher im Metallhalter, für Innensechskant-Schrauben nach DIN 912, DIN 911 / ISO 2936, gefast, Chrom-Vanadium-Stahl 59 CrMo 4, vernickelt

Set of Hexagon Key Wrenches, in metal holder, for hexagon head screws according to DIN 912, DIN 911 / ISO 2936, chamfered, Chrome-Vanadium-Steel 59 CrMo 4 (1.2243), nickel plated

Art.-Nr. / No.	g	VE	EUR
7-tlg. / pcs.: 2,5 / 3 / 4 / 5 / 6 / 8 / 10mm 0440 00 21	380	5	14,95



Art.-Nr. / No.	 g	 VE	EUR	440
8-tlg. / pcs.: 2 / 2,5 / 3 / 4 / 5 / 6 / 8 / 10mm 0440 00 23	295	5	7,95	

Satz 6-kant-Winkelschraubendreher in ABS-Schiebekassette, für Innensechskant-Schrauben nach DIN 912, DIN 911 / ISO 2936, gefast, Chrom-Vanadium-Stahl 59 CrMo 4, vernickelt

Set of Hexagon Key Wrenches, in ABS plastic box, for hexagon head screws according to DIN 912, DIN 911 / ISO 2936, chamfered, Chrome-Vanadium-Steel 59 CrMo 4 (1.2243), nickel plated

Winkelschraubendreher Hexagon Key Wrenches







Art.-Nr. / No.	 g	 VE	EUR	440
9-tlg. / pcs.: 1,5 / 2 / 2,5 / 3 / 4 / 5 / 6 / 8 / 10mm 0440 00 24	295	5	6,95	

Satz 6-kant-Winkelschraubendreher in Klemmhalter, für Innensechskant-Schrauben nach DIN 912, DIN 911 / ISO 2936, gefast, Chrom-Vanadium-Stahl 59 CrMo 4, vernickelt

Set of Hexagon Key Wrenches, in clamp holder, for hexagon head screws according to DIN 912, DIN 911 / ISO 2936, chamfered, Chrome-Vanadium-Steel 59 CrMo 4 (1.2243), nickel plated

Winkelschraubendreher Hexagon Key Wrenches







Art.-Nr. / No.	 mm	 mm	 g	 VE	EUR	440 L
0440 00 60	2	98 x 16	5	10	0,50	
0440 00 61	2,5	110 x 18	5	10	0,50	
0440 00 62	3	124 x 20	10	10	0,65	
0440 00 63	4	136 x 25	20	10	0,85	
0440 00 64	5	158 x 28	30	10	1,05	
0440 00 65	6	175 x 32	50	10	1,30	
0440 00 66	8	193 x 36	100	10	2,35	
0440 00 67	10	215 x 40	180	10	3,35	
0440 00 68	12	245 x 45	280	5	4,45	
0440 00 69	14	270 x 55	450	5	6,95	
0440 00 70	17	315 x 63	750	5	12,65	
0440 00 71	19	340 x 70	1050	5	16,90	

6-kant-Winkelschraubendreher, extra lang, für Innensechskant-Schrauben nach DIN 912, DIN 911 / ISO 2936, gefast, Chrom-Vanadium-Stahl 59 CrMo 4, vernickelt

Hexagon Key Wrenches, long type, for hexagon head screws according to DIN 912, DIN 911 / ISO 2936, chamfered, Chrome-Vanadium-Steel 59 CrMo 4 (1.2243), nickel plated

Winkelschraubendreher, extra lang Hexagon Key Wrenches, long type

DIN 912	mm
M1,6	1,5
M2	1,5
M2,5	2
M3	2,5
M4	3
M5	4
M6	5
M8	6
M10	8
M12	10
M14	12
M16	14
M18	14
M20	17
M22	17
M24	19
M27	19
M30	22
M33	24
M36	27
M42	32
M48	36

Art.-Nr. / No.	 AF	 mm	 g	 VE	EUR
0440 01 63	1/8	95 x 25	20	10	0,70
0440 01 64	5/32	105 x 28	30	10	0,90
0440 01 65	3/16	114 x 32	50	10	1,05
0440 01 66	7/32	124 x 36	100	10	1,25
0440 01 67	1/4	133 x 40	180	10	1,35
0440 01 68	5/16	153 x 45	280	10	2,75
0440 01 69	3/8	172 x 55	450	10	3,60
0440 01 71	1/2	210 x 70	1050	10	4,80



Winkelschraubendreher / Allen Keys

Winkelschraubendreher, extra lang Hexagon Key Wrenches, long type



440 L

Satz 6-kant-Winkelschraubendreher in ABS-Schiebekassette, extra lang, für Innensechskant-Schrauben nach DIN 912, DIN 911 / ISO 2936, gefast, Chrom-Vanadium-Stahl 59 CrMo 4, vernickelt

Set of Hexagon Key Wrenches, in ABS plastic box, long type, for hexagon head screws according to DIN 912, DIN 911 / ISO 2936, chamfered, Chrome-Vanadium-Steel 59 CrMo 4 (1.2243), nickel plated

Art.-Nr. / No.



EUR

8-tlg. / pcs.:

2 / 2,5 / 3 / 4 / 5 / 6 / 8 / 10mm

0440 02 00

500 5 16,50

Winkelschraubendreher, extra lang Hexagon Key Wrenches, long type



440 L

Satz 6-kant-Winkelschraubendreher in Klemmhalter, extra lang, für Innensechskant-Schrauben nach DIN 912, DIN 911 / ISO 2936, gefast, Chrom-Vanadium-Stahl 59 CrMo 4, vernickelt

Set of Hexagon Key Wrenches, in clamp holder, long type, for hexagon head screws according to DIN 912, DIN 911 / ISO 2936, chamfered, Chrome-Vanadium-Steel 59 CrMo 4 (1.2243), nickel plated

Art.-Nr. / No.



EUR

9-tlg. / pcs.:

1,5 / 2 / 2,5 / 3 / 4 / 5 / 6 / 8 / 10mm

0440 03 00

420 5 12,95

Winkelschraubendr., Kugelkopf Hexagon Key Wrenches, ballpoint

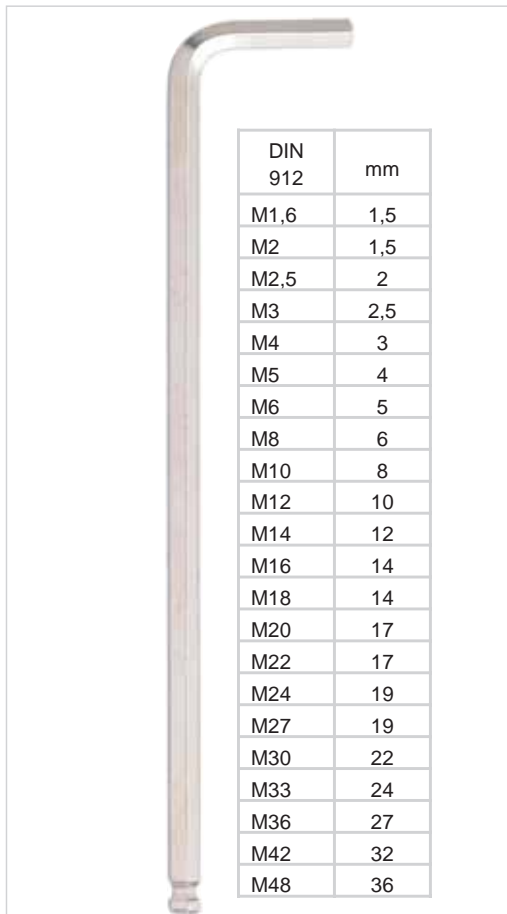

444 L

6-kant-Winkelschraubendreher, extra lang, mit Kugelkopf, für Innensechskant-Schrauben nach DIN 912, ideal für Schrauben an schwer zugänglichen Stellen, da schwenkbar bis 30°, DIN 911 / ISO 2936, gefast, Chrom-Vanadium-Stahl 59 CrMo 4, vernickelt

Hexagon Key Wrenches, long type, with ballpoint, for hexagon head screws according to DIN 912, for use in awkward areas, swivel angle up to 30°, DIN 911 / ISO 2936, chamfered, Chrome-Vanadium-Steel 59 CrMo 4 (1.2243), nickel plated

Art.-Nr. / No.



mm



mm



EUR

Art.-Nr. / No.	mm	mm	g	VE	EUR
0444 00 11	1,5	90 x 14	1,5	10	1,10
0444 00 12	2	100 x 16	3	10	1,10
0444 00 01	2,5	112 x 18	6	10	1,10
0444 00 02	3	126 x 20	9	10	1,15
0444 00 03	4	140 x 25	18	10	1,30
0444 00 04	5	160 x 28	32	10	1,40
0444 00 05	6	180 x 32	52	10	1,50
0444 00 06	8	200 x 36	103	10	2,50
0444 00 07	10	224 x 40	180	10	4,05
0444 00 08	12	250 x 45	290	10	5,70
0444 00 09	14	270 x 55	450	5	6,95
0444 00 10	17	315 x 63	750	5	11,80
0444 00 13	19	340 x 70	1050	5	14,60

30° Schwenkwinkel durch Kugelkopf .
Ballpoint for use in awkward areas.



Art.-Nr. / No.



AF



mm



EUR

Art.-Nr. / No.	AF	mm	g	VE	EUR
0444 01 01	1/16	82 x 15	2	10	1,05
0444 01 02	5/64	87 x 20	4	10	1,10
0444 01 03	3/32	93 x 22	6	10	1,10
0444 01 04	1/8	95 x 25	9	10	1,10
0444 01 05	5/32	105 x 28	19	10	1,25
0444 01 06	3/16	114 x 32	32	10	1,40
0444 01 07	7/32	124 x 36	45	10	1,50
0444 01 08	1/4	133 x 40	56	10	1,55
0444 01 10	5/16	153 x 45	105	10	2,55
0444 01 12	3/8	172 x 55	183	10	3,40
0444 01 14	1/2	210 x 70	360	10	3,40

Art.-Nr. / No.	g	VE	EUR	444 L
9-tlg. / pcs.: 1,5 / 2 / 2,5 / 3 / 4 / 5 / 6 / 8 / 10mm 0444 00 20	420	5	19,95	

30° Schwenkwinkel durch Kugelkopf.
Ballpoint for use in awkward areas.

9-tlg.-Satz 6-kant-Winkelschraubendreher, extra lang, mit Kugelkopf, im Klemmhalter, für Innensechskant-Schrauben nach DIN 912, ideal für Schrauben an schwer zugänglichen Stellen, da schwenkbar bis 30°, DIN 911 / ISO 2936, gefast, Chrom-Vanadium-Stahl 59 CrMo 4, vernickelt

Set of Hexagon Key Wrenches, long type, with ballpoint, 9-pcs., in clamp holder, for hexagon head screws according to DIN 912, for use in awkward areas, swivel angle up to 30°, DIN 911 / ISO 2936, chamfered, Chrome-Vanadium-Steel 59 CrMo 4 (1.2243), nickel plated

Winkelschraubendr., Kugelkopf
Hexagon Key Wrenches, ballpoint



Art.-Nr. / No.	TX	mm	g	VE	EUR	442
0442 00 01	TX 6	44	2,5	10	3,30	
0442 00 02	TX 7	48	2,5	10	3,30	
0442 00 03	TX 8	48	3	10	3,30	
0442 00 04	TX 9	48	3,5	10	3,30	
0442 00 05	TX 10	51	4	10	3,50	
0442 00 06	TX 15	54	5	10	3,65	
0442 00 07	TX 20	57	7	10	3,80	
0442 00 08	TX 25	60	10	10	3,95	
0442 00 09	TX 27	64	15	10	4,25	
0442 00 10	TX 30	70	20	10	4,50	
0442 00 11	TX 40	76	30	10	5,30	

6-kant-Winkelschraubendreher, für Innen-TORX-Schrauben, gefast, Chrom-Vanadium-Stahl 59 CrMo 4, brüniert

Key Wrenches, for inside TORX screws, chamfered, Chrome-Vanadium-Steel 59 CrMo 4 (1.2243), black phosphated

Winkelschraubendreher, TORX
Key Wrenches, TORX



Art.-Nr. / No.	g	VE	EUR	442
8-tlg. / pcs.: TX 9 / 10 / 15 / 20 / 25 / 27 / 30 / 40 0442 00 20	235	5	24,95	

8-tlg.-Satz 6-kant-Winkelschraubendreher im Metallhalter, für Innen-TORX-Schrauben, gefast, Chrom-Vanadium-Stahl 59 CrMo 4, brüniert

Set of Key Wrenches, for inside TORX screws, 8-pcs., in metal holder, chamfered, Chrome-Vanadium-Steel 59 CrMo 4 (1.2243), black phosphated

Winkelschraubendreher, TORX
Key Wrenches, TORX



Art.-Nr. / No.	TX	mm	g	VE	EUR	443
0443 00 02	TX 10	76	4	10	3,60	
0443 00 03	TX 15	87	5	10	3,80	
0443 00 04	TX 20	98	7	10	3,90	
0443 00 05	TX 25	100	10	10	4,10	
0443 00 06	TX 27	110	15	10	4,30	
0443 00 07	TX 30	125	20	10	4,70	
0443 00 08	TX 40	140	30	10	5,40	

30° Schwenkwinkel durch Kugelkopf.
Ballpoint for use in awkward areas.

6-kant-Winkelschraubendreher, extra lang, für Innen-TORX-Schrauben, mit Kugelkopf am langen Ende, ideal für Schrauben an schwer zugänglichen Stellen, da schwenkbar bis 30°, gefast, Chrom-Vanadium-Stahl 59 CrMo 4, brüniert

Key Wrenches, long type, for inside TORX-screws, with ballpoint, for use in awkward areas, swivel angle up to 30°, chamfered, Chrome-Vanadium-Steel 59 CrMo 4 (1.2243), black phosphated

Winkelschraubendreher, TORX, KK
Key Wrenches, TORX, Ballpoint



Schraubendreher / Screwdrivers

Winkelschraubendr., TORX, KK Key Wrenches, TORX, Ballpoint



443

8-tlg.-Satz 6-kant-Winkelschraubendreher, im Klemmhalter, für Innen-TORX-Schrauben, mit Kugelkopf am langen Ende, ideal für Schrauben an schwer zugänglichen Stellen, da schwenkbar bis 30°, gefast, Chrom-Vanadium-Stahl 59 CrMo 4, brüniert

Set of Key Wrenches, for inside TORX-screws, 8-pcs., in clamp holder, with ballpoint, for use in awkward areas, swivel angle up to 30°, chamfered, Chrome-Vanadium-Steel 59 CrMo 4 (1.2243), black phosphated

Art.-Nr. / No.



EUR

8-tlg. / pcs.: 29,95
TX 9 / 10 / 15 / 20 / 25 / 27 / 30 / 40
0443 00 20 TX 9 - TX 40 160 5

30° Schwenkwinkel durch Kugelkopf.
Ballpoint for use in awkward areas.



Winkelschraubendr., T-Griff, KK Hexagon Key Wrenches, T-Handle

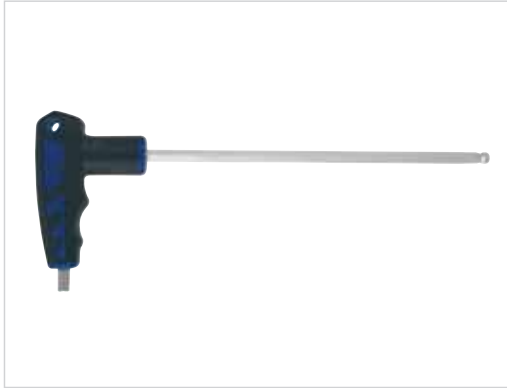

441

6-kant-Winkelschraubendreher mit T-Griff und Kugelkopf am langen Ende, 2-Komponenten-Griff mit weicher und harter Griffzone, für Innensechskant-Schrauben nach DIN 912, DIN 911 / ISO 2936, Chrom-Vanadium-Stahl, matt verchromt

T-Handle Hexagon Key Wrenches, with ballpoint on long side, with dual component handle with hard and soft grip zone, for hexagon head screws according to DIN 912, DIN 911 / ISO 2936, Chrome-Vanadium-Steel, matt chrome finish

Art.-Nr. / No.



EUR

Art.-Nr. / No.	mm	VE	EUR
0441 10 20	2,0 x 100	10	2,30
0441 10 30	3,0 x 100	10	2,50
0441 10 40	4,0 x 150	10	2,60
0441 10 50	5,0 x 150	10	3,20
0441 10 60	6,0 x 200	10	3,50
0441 10 80	8,0 x 200	10	4,20
0441 11 00	10,0 x 200	10	6,50

30° Schwenkwinkel durch Kugelkopf.
Ballpoint for use in awkward areas.

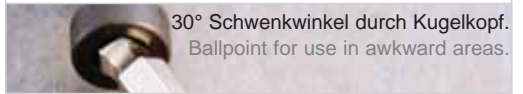

Winkelschraubendr., T-Griff, TORX Key Wrenches, T-Handle, TORX

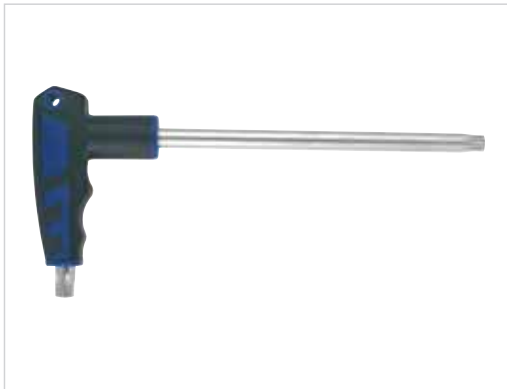

441

6-kant-Winkelschraubendreher mit T-Griff, 2-Komponenten-Griff mit weicher und harter Griffzone, für Innen-TORX-Schrauben, Chrom-Vanadium-Stahl, matt verchromt

T-Handle Key Wrenches, with dual component handle with hard and soft grip zone, for TORX-screws, Chrome-Vanadium-Steel, matt chrome finish

Art.-Nr. / No.



EUR

Art.-Nr. / No.	TX	VE	EUR
0441 21 00	TX 10	10	3,95
0441 21 50	TX 15	10	4,05
0441 22 00	TX 20	10	4,60
0441 22 50	TX 25	10	4,85
0441 22 70	TX 27	10	5,05
0441 23 00	TX 30	10	5,50
0441 24 00	TX 40	10	6,20
0441 24 50	TX 45	5	6,30
0441 25 00	TX 50	5	9,30

Holzheft-Schraubendreher Screwdrivers with wooden handle



600

Schraubendreher für Schlitzschrauben, mit durchgehender Klinge und Holzheft mit Lederkappe, Klinge mit Sechskant, schwarze Spitze, Schneide nach DIN 5264/ISO 2380

Screwdrivers for plain slot screws, with blade through handle, wooden handle with leather cap, blade with hexagon bolster, black tip, blade edge according to DIN 5264/ISO 2380

Art.-Nr. / No.



EUR

Art.-Nr. / No.	mm	mm	mm	g	VE	EUR
0600 00 01	0,6x3,5	75	170	45	10	4,50
0600 00 02	0,8x4,5	90	190	55	10	4,60
0600 00 03	1,0x5,5	100	200	70	10	5,50
0600 00 04	1,2x7,0	125	240	100	10	6,50
0600 00 05	1,2x8,0	150	275	160	10	7,75
0600 00 06	1,6x10,0	175	300	210	10	8,20
0600 00 07	2,0x12,0	200	335	280	5	10,30
0600 00 08	2,5x14,0	250	395	430	5	11,30

Art.-Nr. / No.	PH	mm	mm	g	VE	EUR	650
0650 00 01	1	80	180	55	10	5,95	<p>Schraubendreher für Kreuzschlitzschrauben Phillips-Recess, mit durchgehender Klinge und Holzheft mit Lederkappe, Klinge mit Sechskant, schwarze Spitze, Schneide nach DIN 5260-PH/ISO 8764-PH</p> <p>Screwdrivers for cross slot screws Phillips-Recess, with blade through handle, wooden handle with leather cap, blade with hexagon bolster, black tip, blade edge according to DIN 5260-PH/ISO 8764-PH</p>
0650 00 02	2	100	225	60	10	7,20	
0650 00 03	3	150	270	160	10	8,70	
0650 00 04	4	200	340	270	5	12,20	

Holzheft-Schraubendreher (PH)

Screwdrivers with wooden handle (PH)



Art.-Nr. / No.	6-tlg. / pcs.	g	EUR	650
0650 00 50	6-tlg. / pcs.	500	34,95	<p>Satz Schraubendreher, mit durchgehender Klinge und Holzheft mit Lederkappe, Klinge mit Sechskant, schwarze Spitze</p> <p>Set of Screwdrivers, with blade through handle, wooden handle with leather cap, blade with hexagon bolster, black tip</p> <p>Inhalt / content: 0,6 x 3,5 (600) 0,8 x 4,5 1,0 x 5,5 1,2 x 7,0 PH 1, PH 2 (650)</p>



Holzheft-Schraubendreher

Screwdrivers with wooden handle



Art.-Nr. / No.	mm	mm	mm	g	VE	EUR	615
0615 20 10	0,8x4,0	75	175	58	10	4,60	<p>Werkstatt-Schraubendreher, nach DIN 5265, Form C, Schneide nach DIN 5264, Form A / ISO 2380, mit 2-Komponenten-Griff, schwarze Spitze, Klinge verchromt, Chrom-Vanadium</p> <p>Workshop-Screwdrivers, according to DIN 5265, Form C, blade tip according to DIN 5264, Form A / ISO 2380, with dual component handle, black tip, blade chrome plated, Chrome-Vanadium</p>
0615 20 20	0,8x5,0	100	200	70	10	4,65	
0615 20 30	1,0x5,5	125	235	89	10	5,60	
0615 20 40	1,2x6,5	150	260	108	10	6,65	
0615 20 50	1,2x8,0	175	295	151	5	7,90	
0615 20 60	1,6x10,0	200	320	215	5	9,45	
0615 20 70	2,0x12,0	250	370	243	5	10,65	

2K-Werkstatt-Schraubendreher

2C-Workshop Screwdrivers



Art.-Nr. / No.	mm	mm	mm	g	VE	EUR	605
0605 20 10	1,0x5,5	100	210	90	10	6,25	<p>Schraubendreher, nach DIN 5265, Form C, Schneide nach DIN 5264, Form A / ISO 2380, mit 2-Komponenten-Griff, schwarze Spitze, Klinge mit Sechskant zur Drehmomentverstärkung in Verbindung mit Schraubenschlüssel, Klinge verchromt, Chrom-Vanadium</p> <p>Workshop-Screwdrivers, according to DIN 5265, Form C, blade tip according to DIN 5264, Form A / ISO 2380, with dual component handle, black tip, blade with hexagon bolster for spanner drive, blade chrome plated, Chrome-Vanadium</p>
0605 20 20	1,2x6,5	125	235	107	10	7,20	
0605 20 30	1,2x8,0	150	270	179	10	9,00	
0605 20 40	1,6x10,0	175	295	187	10	10,00	
0605 20 50	2,0x12,0	200	320	269	5	12,25	
0605 20 60	2,5x14,0	250	370	310	5	14,60	

2K-Schraubendreher mit Sechskant

2C-Screwdrivers with hexagon bolster



Schraubendreher / Screwdrivers

2K-Schraubendreher (PH) 2C-Screwdrivers (PH)



655

Schraubendreher, für Kreuzschlitzschrauben Phillips-Recess, DIN 5262, Form B, Spitze nach DIN 5260-PH / ISO 8764-PH, mit 2-Komponenten-Griff, schwarze Spitze, Klinge verchromt, Chrom-Vanadium

Screwdrivers, for cross slot screws Phillips-Recess, according to DIN 5262, Form B, blade tip according to DIN 5260-PH / ISO 8764-PH, with dual component handle, black tip, blade chrome plated, Chrome-Vanadium

Art.-Nr. / No.	PH	mm	mm	g	VE	EUR
0655 20 00	0	60	150	43	10	4,40
0655 20 10	1	80	180	66	10	5,10
0655 20 20	2	100	210	97	10	6,05
0655 20 30	3	150	270	165	10	8,75
0655 20 40	4	200	320	250	5	10,65

2K-Schraubendreher (PH) Sechsk. 2C-Screwdrivers (PH) hex. bolster



658

Schraubendreher, für Kreuzschlitzschrauben Phillips-Recess, DIN 5262, Form B, Spitze nach DIN 5260-PH / ISO 8764-PH, mit 2-Komponenten-Griff, schwarze Spitze, Klinge mit Sechskant zur Drehmomentverstärkung in Verbindung mit Schraubenschlüssel, Klinge verchromt, Chrom-Vanadium

Screwdrivers, for cross slot screws Phillips-Recess, according to DIN 5262, Form B, blade tip according to DIN 5260-PH / ISO 8764-PH, with dual component handle, black tip, blade with hexagon bolster for spanner drive, blade chrome plated, Chrome-Vanadium

Art.-Nr. / No.	PH	mm	mm	g	VE	EUR
0658 20 10	1	80	180	52	5	7,00
0658 20 20	2	100	210	86	5	7,50
0658 20 30	3	150	270	150	5	10,10
0658 20 40	4	200	320	285	5	14,15

2K-Schraubendreher (PZ) 2C-Screwdrivers (PZ)



657

Schraubendreher, für Kreuzschlitzschrauben Supa-Pozidriv, Spitze nach DIN 5260-PZ / ISO 8764-PZ, mit 2-Komponenten-Griff, schwarze Spitze, Klinge verchromt, Chrom-Vanadium

Screwdrivers, for cross slot screws Supa-Pozidriv, tip according to DIN 5260-PZ / ISO 8764-PZ, with dual component handle, black tip, blade chrome plated, Chrome-Vanadium

Art.-Nr. / No.	PZ	mm	mm	g	VE	EUR
0657 20 00	0	60	150	43	10	4,60
0657 20 10	1	80	180	66	10	5,60
0657 20 20	2	100	210	97	10	6,65
0657 20 30	3	150	270	165	10	9,70
0657 20 40	4	200	320	250	5	12,40

2K-Sechskant-Steckschlüssel 2C-Hexagon Nut Drivers



670

Schraubendreher mit Sechskant-Steckschlüssel, DIN 3125 / ISO 2725, Chrom-Vanadium-Stahl 31 CrV 3 (W.-Nr. 1.2208), mit 2-Komponenten-Griff, poliert, verchromt

Nut Hexagon Nut Drivers, DIN 3125 / ISO 2725, with dual component handle, Chrome-Vanadium-Steel 31 CrV 3 (W.-Nr. 1.2208), with dual compound handle, polished, chrome plated

Art.-Nr. / No.	mm	mm	mm	g	VE	EUR
0670 20 50	5	125	225	85	10	6,50
0670 20 60	6	125	225	86	10	7,00
0670 20 70	7	125	235	121	10	7,30
0670 20 80	8	125	235	122	10	7,60
0670 21 00	10	125	235	125	10	7,70

Art.-Nr. / No.	mm	mm	mm	g	VE	EUR	670
0670 00 50	5	150	260	142	10	13,20	<p>Schraubendreher mit Sechskant-Steckschlüssel, mit flexiblem Schaft, DIN 3125 / ISO 2725, Chrom-Vanadium-Stahl 31 CrV 3 (W.-Nr. 1.2208), mit 2-Komponenten-Griff, poliert, verchromt</p> <p>Hexagon Nut Drivers, with flexible shaft, DIN 3125 / ISO 2725, with dual compound handle, Chrome-Vanadium-Steel 31 CrV 3 (1.2208), with dual component handle, polished, chrome plated</p>
0670 00 60	6	150	260	142	10	13,60	
0670 00 70	7	150	260	142	10	13,90	
0670 00 80	8	150	260	162	10	14,30	
0670 00 90	10	155	265	167	10	14,70	

2K-Sechskant-Steckschlüssel 2C-Hexagon Nut Drivers



Art.-Nr. / No.	mm	mm	mm	g	VE	EUR	671
0671 00 55	5,5	230	265	123	10	6,15	<p>Schraubendreher mit Sechskant-Steckschlüssel, mit PP-Quergriff, DIN 3125 / ISO 2725, Chrom-Vanadium-Stahl 31 CrV 3 (W.-Nr. 1.2208), poliert, verchromt</p>
0671 00 60	6	230	265	125	10	6,20	
0671 00 70	7	230	265	151	10	6,40	
0671 00 80	8	230	265	151	10	6,65	
0671 00 90	9	230	265	155	10	6,75	
0671 01 00	10	230	265	193	10	6,95	<p>Nut Hexagon Nut Drivers, DIN 3125 / ISO 2725, with PP-T-handle, Chrome-Vanadium-Steel 31 CrV 3 (1.2208), polished, chrome plated</p>
0671 01 10	11	230	265	195	10	7,60	
0671 01 20	12	230	275	234	10	8,40	
0671 01 30	13	230	275	236	10	8,95	
0671 01 40	14	230	275	247	10	9,45	

Sechskant-Steckschlüssel T-Griff Hexagon Nut Drivers T-Handle



Art.-Nr. / No.	Griff / Handle	g	VE	EUR	672	
0672 00 10	Griff / Handle	42	5	5,95	<p>Schraubendreher und T-Griff in einem, ersetzt zahlreiche Einzelwerkzeuge, auch passend für 1/4"-Werkzeuge, Griff aus Cellulose-Acetat - absolut schlagfest, temperatur- und alterungsbeständig, Griffkopf mit Abrollschutz, Klingen aus Hochleistungs-Bitstählen, Härte/Drehmoment bis zu 100% über DIN-Werten</p> <p>Screwdriver and T-handle in one, replaces several single tools, fitting also in 1/4"-range, handle made of cellulose acetate - high impact resistant, temperature and age-proof, blades made from high-quality bit-steels, exceeding the DIN/ISO requirements by up to 100%, black-tip for precision and perfect fit</p>	
0672 00 11	PH 1	4,0x0,8	40	5		5,95
0672 00 12	PH 2	PH 3	40	5		5,95
0672 00 13	PZ 1	5,0x0,8	40	5		5,95
0672 00 14	PZ 2	6,0x1,0	40	5		5,95
0672 00 15	PZ 3	7,0x1,2	40	5		5,95
0672 00 16	3mm	4mm	40	5		5,95
0672 00 17	5mm	6mm	40	5		5,95
0672 00 18	TX 10	TX 15	40	5		6,50
0672 00 19	TX 20	TX 25	40	5		6,50
0672 00 20	TX 30	TX 40	40	5		6,50

Umsteckbarer Schraubendreher Reversible Blade Screwdriver



Art.-Nr. / No.	11-tlg. / pcs.	g	EUR	ModuFlex 672
0672 60 01	11-tlg. / pcs.	600	39,00	<p>11-tlg. Satz in Kunststoffkoffer, mit zweifarbigem MTS-System, passt in Werkstattwagen</p> <p>11-pcs. set in plastic case, with two coloured MTS-System, fits into trolley modules</p> <p>Inhalt / content: PH 1 - 4,0x0,8, PH 2 - PH 3 PZ 1 - 5,0x0,8, PZ 2 - 6,0x1,0 PZ 3 - 7,0x1,2 3mm - 4mm, 5mm - 6mm TX 10 - 15, 20 - 25, 30 - 40</p> <p>Griff / Handle</p>



Satz umsteckbare Schraubendreher Set of reversible blade screwdrivers



Schraubendreher für Elektriker.

Screwdrivers for Electricians.

2K-Schraubendreher VDE 2C-Screwdrivers VDE

1000 V



616

Schraubendreher, DIN 7437, 2-Komponenten-Griff, Molybdän-Vanadium / Chrom-Silizium-Vanadium / Chrom-Vanadium, isoliert und geprüft nach VDE-Vorschrift DIN ISO EN 60900 (VDE 0682 Teil 201)

Screwdrivers, with dual component handle, chrome-molybdenum / chrome-silicon-vanadium / chrome vanadium, insulated and tested according to VDE DIN EN 60900 (VDE 0682 Part 201)

Art.-Nr. / No.	mm	mm	mm	g	VE	EUR
0616 20 10	2,5	75	165	40	10	4,35
0616 20 20	3,5	100	190	47	10	4,80
0616 20 30	4	100	200	63	10	5,30
0616 20 40	5,5	125	235	96	10	5,95
0616 20 50	6,5	150	260	119	10	6,75
0616 20 60	8	175	295	182	5	9,10
0616 20 70	10	200	320	248	5	11,20

Spannungsprüfer Voltage Testers



635

Nach VDE 0680, bis 230V, mit Metallclip, Griff transparent, Klinge vernickelt und kunststoffummantelt, Klinge aus Spezialstahl

As per VDE 0680, up to 230V, with metal clip, transparent handle, insulated blade, blade made from high grade tool steel, nickel plated

Art.-Nr. / No.	mm	mm	mm	g	VE	EUR
0635 00 01	3	65	140	20	10	2,35
0636 00 01	3,5	100	195	45	10	3,15

2K-Schraubendreher VDE (PH) 2C-Screwdrivers VDE (PH)

1000 V



656

Kreuzschlitz-Schraubendreher, DIN 7438, für Phillips-Recess-Schrauben, mit 2-Komponenten-Griff, Molybdän-Vanadium / Chrom-Vanadium, isoliert und geprüft nach VDE-Vorschrift DIN ISO EN 60900 (VDE 0682 Teil 201)

Screwdrivers for Phillips-Recess cross slotted screws, with dual compound handle, chrome-molybdenum / chrome-vanadium, insulated and tested according to VDE DIN EN 60900 (VDE 0682 Part 201)

Art.-Nr. / No.	mm	mm	mm	g	VE	EUR
0656 20 00	0	60	150	43	10	4,70
0656 20 10	1	80	180	68	10	5,50
0656 20 20	2	100	210	98	10	6,65
0656 20 30	3	150	270	167	10	9,45

Schraubendreher-Satz VDE Set of screwdrivers VDE

1000 V







681

VDE-Schraubendreher-Sortiment in Sichtverpackung, mit 2-Komponenten-Griffen, isoliert und geprüft nach VDE-Vorschrift DIN 60900 (VDE 0682 Teil 201)



VDE-Screwdriver assortment in display box, with dual compound handles; insulated and tested according to VDE regulation DIN 60900 (VDE 0682 Part 201)

Art.-Nr. / No.	g	EUR
0681 00 01	6-tlg. / pcs. 515	31,90
	2.5 x 75, 3.5 x 100, 5.5 x 125mm (616)	
	3mm (635)	
	PH 1 + PH 2 (656)	

Art.-Nr. / No.	 mm	 mm	 mm	 g	 VE	EUR	660
0660 20 10	2,5	75	165	39	10	4,05	Elektriker-Schraubendreher, nach DIN 5265, Form C, Schneide nach DIN 5264, Form A / ISO 2380, mit 2-Komponenten-Griff, schwarze Spitze, Klinge verchromt, Chrom-Vanadium Electricians-Screwdrivers, according to DIN 5265, Form C, blade tip according to DIN 5264, Form A / ISO 2380, with dual component handle, black tip, blade chrome plated, Chrome-Vanadium
0660 20 20	3	100	190	42	10	4,15	
0660 20 30	4	100	200	61	10	4,70	
0660 20 40	5	150	250	80	10	5,50	

Elektroniker-Schraubendreher Electricians Screwdrivers



Art.-Nr. / No.	 mm	 mm	 mm	 g	 VE	EUR	661
0661 20 10	0,25x1,0	50	150	10	10	3,40	Für Schlitz-Schrauben, für Elektronik und Feinmechanik, Klinge matt verchromt mit brüniertes Spitze, mit 2-Komponenten-Griff und drehbarer Kappe For slotted screws, for electronic and fine mechanics use, dull chrome plated blade with black phosphated tip, two component handle with revolving head
0661 20 20	0,4x2,0	50	150	10	10	3,50	
0661 20 30	0,5x3,0	50	150	10	10	3,60	





Elektroniker-Schraubendreher Precision Screwdrivers



Art.-Nr. / No.	 PH	 mm	 mm	 g	 VE	EUR	662
0662 20 10	00	50	150	10	10	3,40	Für Phillips-Recess-Schrauben, für Elektronik und Feinmechanik, Klinge matt verchromt mit brüniertes Spitze, mit 2-K-Griff und drehbarer Kappe For Phillips-Recess screws, for electronic and fine mechanics use, dull chrome plated blade with black phosphated tip, two component handle with revolving head
0662 20 20	0	50	150	10	10	3,50	
0662 20 30	1	50	150	10	10	3,60	

Elektroniker-Schraubendreher Precision Screwdrivers



Art.-Nr. / No.	 TX	 mm	 mm	 g	 VE	EUR	663
0663 20 10	5	50	150	10	10	3,75	Für Innen-TORX-Schrauben, für Elektronik und Feinmechanik, Klinge matt verchromt mit brüniertes Spitze, mit 2-K-Griff und drehbarer Kappe For inside TORX screws, for electronic and fine mechanics use, dull chrome plated blade with black phosphated tip, two component handle with revolving head
0663 20 20	6	50	150	10	10	3,75	
0663 20 30	7	50	150	10	10	3,80	
0663 20 40	8	50	150	10	10	3,90	
0663 20 50	10	50	150	10	12	4,10	
0663 20 60	15	50	150	10	12	4,20	

Elektroniker-Schraubendreher Precision Screwdrivers



Art.-Nr. / No.	 g	EUR	ModuFlex	665
0665 60 01	6-tlg. / pcs. 0,25x1,0 (661) 0,4x2,0 0,5x3,0 PH 00, 0, 1 (662)	80	21,00	6-tlg. Satz in Kunststoffkoffer, mit zweifarbigen MTS-System, passt in Werkstattwagen 6-pcs. set in plastic case, with two coloured MTS-System, fits into trolley modules
0665 60 02	6-tlg. / 6-pcs. TX 5 (663) TX 6 TX 7 TX 8 TX 10 TX 15	80	23,00	

Satz Elektroniker-Schraubendreher Set of Precision Screwdrivers



Schraubendreher für die Werkstatt.

Screwdrivers for Automotive.

2K-Schraubendreher TORX Screwdrivers with 2C-Handle TORX



620

Schraubendreher für Innen-TORX-Schrauben, mit 2-Komponenten-Griff, schwarze Spitze, Klinge verchromt, Chrom-Vanadium

Screwdrivers for inside TORX-screws, with dual component handle, black tip, blade chrome plated, Chrome-Vanadium

Art.-Nr. / No.	TX	mm	mm	g	VE	EUR
0620 20 10	6	70	160	41	5	5,95
0620 20 20	7	70	160	41	5	5,95
0620 20 30	8	70	160	41	5	5,95
0620 20 40	9	70	160	41	5	5,95
0620 20 50	10	80	180	41	5	6,40
0620 20 60	15	80	180	57	5	6,40
0620 20 70	20	90	190	61	5	6,75
0620 20 80	25	90	190	65	5	6,85
0620 20 90	27	110	220	93	5	7,50
0620 21 00	30	110	220	99	5	7,85
0620 21 10	40	120	240	135	5	9,50
0620 21 20	45	120	240	155	5	10,30
0620 21 30	50	120	240	175	5	12,30

2K-Schraubendreher, extra lang 2C-Screwdrivers, long type



Werkstatt-Schraubendreher, extra lang, ideal für tief-liegende Verschraubungen z. B. am Armaturenbrett und an der Karosserie, mit 2-Komponenten-Griff, schwarze Spitze, Klinge verchromt, Chrom-Vanadium

Anwendung: z. B. TX 30 zum Ein- und Ausbau der Scheinwerfer an AUDI A4 (ab Bj. 2004) und der Kotflügelverschraubungen an BMW E 46



Workshop-Screwdrivers, extra long, perfect for low-lying screws in dashboard or car body, with dual component handle, black tip, blade chrome plated, Chrome-Vanadium

Application: e.g. TX 30 for installing and removing the headlights on AUDI A4 (since 2004) and the mudguard screws on BMW E 46



Innen-TORX / Inside TORX screws:

Art.-Nr. / No.	mm	mm	g	VE	EUR	
Schlitz / Slotted:						
0615 20 11	4	250	350	240	5	6,95
0615 20 31	5,5	250	360	245	5	7,60
Philips-Recess						
0655 20 11	PH 1	250	350	240	5	7,30
0655 20 21	PH 2	250	360	245	5	7,95
Innen-TORX / Inside TORX screws:						
0620 20 61	TX 15	250	350	240	5	7,95
0620 20 71	TX 20	250	350	240	5	8,10
0620 20 81	TX 25	250	350	240	5	8,25
0620 20 91	TX 27	250	350	240	5	8,35
0620 21 01	TX 30	250	350	240	5	8,45
0620 21 11	TX 40	250	350	240	5	8,80



Satz 2K-Schraubendreher TORX Set of 2C-Screwdrivers TORX







680

Schraubendreher-Sortiment für Innen-TORX-Schrauben, in Sichtverpackung, mit 2-Komponenten-Griffen





Screwdrivers assortment for inside TORX-screws, with dual component handle, black tip, blade chrome plated, Chrome-Vanadium

Art.-Nr. / No.	g	EUR
0680 00 03	6-tlg. / pcs. 520 TX 10, TX 15, TX 20, TX 25, TX 27, TX 30	39,95

Art.-Nr. / No.	 				EUR	627
	mm	mm	g	VE		
0627 00 01	4,0x0,8	100	25	10	1,70	Für Schlitzschrauben, nach DIN 5200, Klingenspitzen nach DIN 5264/ISO 2380, Chrom-Vanadium 58 CrV 4, W.-Nr. 1.2242, vernickelt
0627 00 02	5,5x1,0	125	35	10	2,50	
0627 00 03	8,0x1,2	150	60	10	4,00	
0627 00 04	10,0x1,6	175	80	10	5,95	
0628 00 01	PH 1+2	100	30	10	2,90	Für Philips-Recess-Schrauben, Ausführung wie oben
0628 00 02	PH 3+4	150	70	10	6,60	





Winkel-Schraubendreher Offset Screwdrivers



Art.-Nr. / No.					EUR	630
	T	mm	g	VE		
0630 00 01	20	250	50	10	9,50	Spezial-Schraubendreher mit T-Griff, mit 5-Sternprofil (IP 20), zum Ein- und Ausbau der Außenspiegel an Mercedes Benz der Baureihen W203 + 211 (C- und E-Klasse) ab Baujahr 2005
						With T-Handle, for inside 5-star screws with centre pin, for installing and removing the exterior mirror on Mercedes Benz Type 203 and 211 (C- and E-class) since 2005



5-Stern-Schraubendreher Offset Screwdrivers (PH)



Art.-Nr. / No.						EUR	632
	mm	mm	mm	g	VE		
0632 00 01	3	50	115	20	10	2,40	Autolichtprüfer, mit Kabel, 6-24 Volt, zur Kontrolle von Licht- und Zündanlagen, z.B. zum Prüfen von Zündkerzen auf Funktion und Verschmutzung für Standard-Zündkerzen mit einer Elektrode, Linse und Metallclip, vernickelt
						Car Light Tester, with cable, 6-24 V, for checking lighting and ignition systems, with metal clip, nickel plated	

Autolichtprüfer Car Light Tester



Art.-Nr. / No.				EUR	633	
	mm	g	VE			
0633 00 01	120	75	10	6,05	Zum Prüfen der Spannung, 6 bis 24V Ausführung mit Spitze, geschraubter Schutzkappe, festem Kabel und Klemme, Klinge aus Chrom-Vanadium 31 CrV 3, W.-Nr. 1.2208	
						Voltage tester, testing range 6 to 24V, with tip, protective cap, fixed cable and clip, blade Chrome-Vanadium steel 1.2208

Autolichtprüfer Voltage Tester



Schraubendreher / Screwdrivers

Vergaser-Schraubendreher Carburettor Screwdrivers



640

Vergaser-Schraubendreher, für Schlitzschrauben, nach DIN 5265, Form A, Schneide nach DIN 5264, Form A/ISO 2380, mit schlagfestem Kunststoffgriff, Länge 75mm

Carburettor Screwdrivers, for slotted screws, according to DIN 5265, form A, blade edge according to DIN 5264, Form A/ISO 2380, with plastic handle, shock resistant, length 75mm

Art.-Nr. / No.	mm	mm	mm	g	VE	EUR
----------------	----	----	----	---	----	-----

0640 00 01	0,8x4,0	25	75	43	10	3,25
0640 00 02	1,2x6,5	25	75	56	10	4,50

Vergaser-Schraubendreher (PH) Carburettor Screwdrivers (PH)



655

Vergaser-Schraubendreher, für Kreuzschlitzschrauben Phillips-Recess, nach DIN 5262, Form D, Spitze nach DIN 5260-PH/ISO 8764-PH, mit schlagfestem Kunststoffgriff, Länge 75mm

Carburettor Screwdrivers, for cross slot screws Phillips-Recess, according to DIN 5262, form D, tip according to DIN 5260-PH/ISO 8764-PH, with plastic handle, shock resistant, length 75mm

Art.-Nr. / No.	PH	mm	mm	g	VE	EUR
----------------	----	----	----	---	----	-----

0655 00 06	1	25	75	46	10	4,05
0655 00 07	2	25	75	52	10	4,25

2K-Schraubendreher-Satz Set of Screwdrivers with 2C-Handle



680

Schraubendreher-Sortiment, in Sichtverpackung, mit 2-Komponenten-Griffen

Screwdrivers assortment, with dual component handle, black tip, blade chrome plated, Chrome-Vanadium

Art.-Nr. / No.	g	EUR
----------------	---	-----

0680 00 01	8-tlg. / pcs. 4,0x75, 5,0x100, 5,5x125, 6,5x150mm (615) 3mm (635) 4mm (640) PH 1 + PH 2 (655)	590	41,10
------------	--	-----	-------

0680 00 02	6-tlg. / pcs. 75x4, 100x5, 125x5,5, 150x6.5mm (615) PH 1 + PH 2 (655)	520	35,40
------------	--	-----	-------

Diamant-Schraubendreher-Satz Set of Diamond Grip-Screwdrivers



680/1

Absolute Neuheit: Schraubendreher-Sortiment "Diamond-Grip" mit diamant-beschichteten Klingenspitzen, deutlich weniger Abnutzung, extrem hohe Drehmomentwerte, in Sichtverpackung, mit 2-Komponenten-Griffen

Brandnew: Screwdrivers assortment "Diamond-Grip" with diamond-coated tips, no wear out-effect, very high torque power, with dual component handle

Art.-Nr. / No.	g	EUR
----------------	---	-----

0680 10 01	5-tlg. / pcs. 3,0x100, 4,0x100, 5,5x125 (615) PH 1 + PH 2 (655)	520	39,00
------------	--	-----	-------

Einzeln auf Anfrage / Single items on request

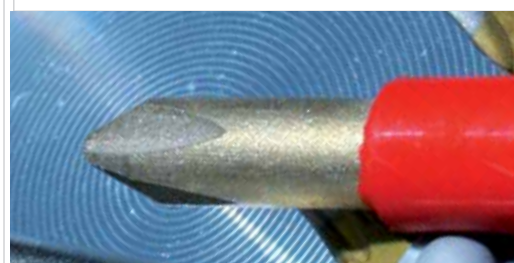

Schraubendreher- Bits.

Screwdriver Insert Bits.

Art.-Nr. / No.	mm	PH	mm	g	VE	EUR	694
0694 00 01	1,2x6,0	2	140	58	10	2,70	Umsteckbarer Schraubendreher, mit Kunststoffheft Reversible Blade Screwdriver, with plastic handle

Umsteck-Schraubendreher Reversible Blade Screwdriver



Art.-Nr. / No.	6-tlg. / pcs.	g	EUR	696
0696 00 04	6-tlg. / pcs.	605	109,90	1/2"-Schlagschraubendreher-Satz zum Lösen fest sitzender Schrauben, in Kunststoffkoffer mit Einlage 1/2"-Impact driver set for loosening tightened screws, in plastic case with inlay Inhalt / content: - 1/2"-Schlagdreher / 1/2"-Impact Driver 120mm - Bithalter für Bits, 1/2"-4-kant - 5/16" 6-kant / Impact Adaptor for Bits 1/2" square - 5/16" hex. - Bits für Schlitzschrauben / Bits for slotted screws 1,2x8 + 2x12mm - Bits für Kreuzschlitzschrauben Phillips-Recess / Bits for Phillips-Recess screws PH 2+3

Schlagschraubendreher-Satz Impact Screwdriver Set



Art.-Nr. / No.	"	"	g	VE	EUR	2085 / 3085 / 4085
2085 00 01	1/4	1/4	15	5	6,90	Zum Einsetzen von Steckschlüsseinsätzen in Maschinenschrauber, z.B. AEG, Bosch, Metabo, Holzher, Black & Decker To use sockets with heavy-duty applications, e.g. AEG, Bosch, Metabo, Holzher, Black & Decker
3085 00 01	3/8	1/4	25	5	7,50	
4085 00 01	1/2	7/16	30	5	7,90	

Verbindungssteile Hex Power Shanks



Art.-Nr. / No.	"	" Bit	g	VE	EUR	2084 / 3086 / 4084
2084 00 01	1/4	1/4	25	5	7,10	Zum Aufsetzen der Bits auf Knarren, für Handbetätigung, mit Innen-4-kant und Innen-6-kant-Aufnahmen, mit Haltekugel für Bits, Chrom Vanadium, matt verchromt For the use with ratchets, for manual operation, with inside square and inside hexagon insert, with clamping ball for bits, Chrome Vanadium, matt chrome finish
3086 00 01	3/8	1/4	35	5	8,60	
3086 00 02	3/8	5/16	40	5	8,60	
4084 00 01	1/2	1/4	45	5	9,65	
4084 00 02	1/2	5/16	60	5	9,65	

Verbindungssteile Adaptors



Schraubendreher-Bits / Screwdriver Bits

Verbindungssteile Adaptors



7040

Zum Einsetzen von 1/4"-Bits in Maschinenschrauber, z.B. AEG, Bosch, Metabo, Holzher, Black & Decker, mit Magnet

To use 1/4"-Bits with heavy-duty applications, e.g. AEG, Bosch, Metabo, Holzher, Black & Decker, with magnet

Art.-Nr. / No.	mm	mm	g	VE	EUR
----------------	----	----	---	----	-----

7040 00 02	1/4	58	27	5	4,05
------------	-----	----	----	---	------

Bits (Schlitz) Bits (slotted)



7020 / 7030

Passend für Schlitzschrauben (DIN 3127 / ISO 2351), für Maschinenschrauber und Handbetrieb, mit 1/4"-bzw. 5/16"-Außensechskant-Antrieb (6,3/8mm), Antrieb nach DIN 3126-C / ISO 1173-C, aus legiertem Sonderstahl, stahlgrau

For slotted screws (DIN 3127 / ISO 2351), for use with air or electric power tools, with hexagon drive 1/4" or 5/16" (6.3/8mm), drive according to DIN 3126-C / ISO 1173-C, high grade tool steel, grey

Art.-Nr. / No.	mm	mm	g	VE	EUR
----------------	----	----	---	----	-----

1/4"					
7020 00 01	0,5 x 4,0	39	6	10	1,50
7020 00 02	0,8 x 5,5	39	7	10	1,50
7020 00 03	1,0 x 5,5	39	8	10	1,50
7020 00 04	1,2 x 8,0	39	11	10	1,50
7020 00 05	1,6 x 10,0	39	16	10	1,50
5/16"					
7030 00 01	0,8 x 5,5	39	11	10	2,00
7030 00 02	1,2 x 6,5	39	12	10	2,00
7030 00 03	1,2 x 8,0	39	14	10	2,00
7030 00 04	1,6 x 8,0	39	15	10	2,00
7030 00 05	2,0 x 12,0	39	24	10	2,00

Bits (Innensechskant) Bits (Hexagon)



7022 / 7032

Passend für Innensechskantschrauben (DIN 7426 / ISO 3109), für Maschinenschrauber und Handbetrieb, mit 1/4"-bzw. 5/16"-Außensechskant-Antrieb (6,3/8mm), Antrieb nach DIN 3126-C / ISO 1173-C, aus legiertem Sonderstahl, stahlgrau

For inside hexagon screws (DIN 7426 / ISO 3109), for use with air or electric power tools, with hexagon drive 1/4" or 5/16" (6.3/8mm), drive according to DIN 3126-C / ISO 1173-C, high grade tool steel, grey

Art.-Nr. / No.	mm	mm	g	VE	EUR
----------------	----	----	---	----	-----

1/4"					
7022 00 01	3	25	5	10	1,50
7022 00 02	4	25	5	10	1,50
7022 00 03	5	25	6	10	1,50
7022 00 04	6	25	6	10	1,50
7022 00 05	8	25	9	10	1,50
5/16"					
7032 00 01	3	30	10	10	2,00
7032 00 02	4	30	10	10	2,00
7032 00 03	5	30	10	10	2,00
7032 00 04	6	30	11	10	2,00
7032 00 05	8	30	12	10	2,00
7032 00 06	10	30	15	10	2,00

Bits (RIBE-CV) Bits (RIBE-CV)



7023 / 7033

Passend für RIBE-CV-Keilzahn-Schrauben (DIN 3128), für Maschinenschrauber und Handbetrieb, mit 1/4"-bzw. 5/16"-Außensechskant-Antrieb (6,3/8mm), 5/16" extra lang, Antrieb nach DIN 3126-C / ISO 1173-C, aus legiertem Sonderstahl, stahlgrau

For RIBE CV-screws (DIN 3128), for use with air or electric power tools, with hexagon drive 1/4" or 5/16" (6.3/8mm), 5/16" long type, drive according to DIN 3126-C / ISO 1173-C, high grade tool steel, grey

Art.-Nr. / No.	mm	mm	g	VE	EUR
----------------	----	----	---	----	-----

1/4"					
7023 00 01	M 5	32	5	10	1,50
7023 00 02	M 6	32	5	10	1,50
7023 00 03	M 8	32	10	10	1,50
5/16"					
7033 00 03	M 8	100	10	10	2,00
7033 00 04	M 10	100	15	10	2,00
7033 00 05	M 12	100	20	10	2,00
7033 00 06	M 14	100	30	10	2,00
7033 00 07	M 16	100	55	10	2,00

Art.-Nr. / No.	PH	mm	g	VE	EUR	7024 / 7034
1/4"						
7024 00 01	1	25	5	10	1,50	Passend für Kreuzschlitzschrauben Philips-Recess (DIN 3128), für Maschinenschrauber und Handbetrieb, mit 1/4"-bzw. 5/16"-Außensechskant-Antrieb (6,3/8mm), Antrieb nach DIN 3126-C / ISO 1173-C, aus legiertem Sonderstahl, stahlgrau
7024 00 02	2	25	5	10	1,50	
7024 00 03	3	25	5	10	1,50	
7024 00 04	4	32	12	10	1,50	
5/16"						
7034 00 01	1	32	10	10	2,00	For cross slot screws Philips Recess (DIN 3128), for use with air or electric power tools, with hexagon drive 1/4" or 5/16" (6.3/8mm), drive according to DIN 3126-C / ISO 1173-C, high grade tool steel, grey
7034 00 02	2	32	10	10	2,00	
7034 00 03	3	32	11	10	2,00	
7034 00 04	4	38	14	10	2,00	

Bits (Philips-Recess)

Bits (Philips-Recess)



Art.-Nr. / No.	TX	mm	g	VE	EUR	7025 / 7035
1/4"						
7025 00 01	6	25	4	10	1,50	Passend für Innen-TORX-Schrauben, für Maschinenschrauber und Handbetrieb, mit 1/4"-bzw. 5/16"-Außensechskant-Antrieb (6,3/8mm), 5/16" extra lang, Antrieb nach DIN 3126-C / ISO 1173-C, aus legiertem Sonderstahl, stahlgrau
7025 00 02	7	25	4	10	1,50	
7025 00 03	8	25	4	10	1,50	
7025 00 04	9	25	4	10	1,50	
7025 00 05	10	25	4	10	1,50	
7025 00 06	15	25	5	10	1,50	
7025 00 07	20	25	5	10	1,50	
7025 00 08	25	25	5	10	1,50	
7025 00 09	27	25	5	10	1,50	
7025 00 10	30	25	5	10	1,50	
7025 00 11	40	25	6	10	1,50	
1/4" lange Ausführung / long type						
7025 00 18	25	100	15	10	2,50	For inside TORX screws, for use with air or electric power tools, with hexagon drive 1/4" or 5/16" (6.3/8mm), 5/16" long type, drive according to DIN 3126-C / ISO 1173-C, high grade tool steel, grey
7025 00 19	30	100	20	10	2,50	
5/16"						
7035 00 01	25	100	10	10	2,95	- TX 25, lange Ausführung, für 3er und 5er Reihe BMW, für Schrauben der Sitzblende und zum Einstellen des Stahlschiebedaches - TX 30, lange Ausführung, zur Demontage und Montage der Airbag-Einheit, z.B. Mercedes Benz, VW-Audi, Opel, Porsche
7035 00 02	27	100	10	10	2,95	
7035 00 03	30	100	11	10	2,95	
7035 00 04	40	100	12	10	2,95	
7035 00 05	45	100	13	10	2,95	
7035 00 06	50	100	15	10	2,95	
7035 00 07	55	100	16	10	2,95	

Bits (TORX)

Bits (ITORX)



Art.-Nr. / No.	TX	mm	g	VE	EUR	7025
1/4"						
7025 10 01	10	25	5	10	1,70	Passend für Tamper-Resistant-TORX-Schrauben (Innen-TORX-Schrauben mit Zapfenführung), für Maschinenschrauber und Handbetrieb, mit 1/4"-Außensechskant-Antrieb (6,3mm), Antrieb nach DIN 3126-C / ISO 1173-C, aus legiertem Sonderstahl, stahlgrau
7025 10 02	15	25	5	10	1,70	
7025 10 03	20	25	5	10	1,70	
7025 10 04	25	25	5	10	1,70	
7025 10 05	27	25	5	10	1,70	
7025 10 06	30	25	5	10	1,70	
7025 10 07	40	25	5	10	1,70	
- TX 30 für Sensorschraube Airbag BMW						
For Tamper resistant TORX screws (inside TORX screws with pin), for use with air or electric power tools, with hexagon drive 1/4" (6.3mm), drive according to DIN 3126-C / ISO 1173-C, high grade tool steel, grey						
- TX 30 for sensor screw (Airbag BMW)						

Bits (Tamper-TORX)

Bits (Tamper TORX)



Schraubendreher-Bits / Screwdriver Bits

Bits (Tamper-TORX), extra lang Bits (Tamper TORX), long type



7035

Passend für Tamper-Resistant-TORX-Schrauben (Innen-TORX-Schrauben mit Zapfenführung), für Maschinenschrauber und Handbetrieb, mit 5/16"-Außensechskant-Antrieb (8mm), extra lang, Antrieb nach DIN 3126-C / ISO 1173-C, aus legiertem Sonderstahl, stahlgrau

For Tamper resistant TORX screws (inside TORX screws with pin), for use with air or electric power tools, with hexagon drive 5/16" (8mm), drive according to DIN 3126-C / ISO 1173-C, high grade tool steel, grey

Art.-Nr. / No.	TX	mm	g	VE	EUR
5/16"					
7035 10 01	25	100	10	10	2,95
7035 10 02	27	100	10	10	2,95
7035 10 03	30	100	11	10	2,95
7035 10 04	40	100	12	10	2,95
7035 10 05	45	100	13	10	2,95
7035 10 06	50	100	15	10	2,95
7035 10 07	55	100	16	10	2,95

Bits (XZN) Bits (XZN)



7026 / 7036

Passend für B&S XZN-Schrauben (Innen-Vielzahn-Schrauben), für Maschinenschrauber und Handbetrieb, mit 1/4"-bzw. 5/16"-Außensechskant-Antrieb (6,3/8mm), Antrieb nach DIN 3126-C / ISO 1173-C, aus legiertem Sonderstahl, stahlgrau

For B&S XZN-screws (internal serration), for use with air or electric power tools, with hexagon drive 1/4" or 5/16" (6.3/8mm), drive according to DIN 3126-C / ISO 1173-C, high grade tool steel, grey

Art.-Nr. / No.	M	mm	g	VE	EUR
1/4"					
7026 00 01	M 4	28	5	10	1,50
7026 00 02	M 5	28	5	10	1,50
5/16"					
7036 00 02	M 6	28	10	10	2,00
7036 00 03	M 8	28	10	10	2,00
7036 00 04	M 10	32	10	10	2,00
7036 00 05	M 12	36	15	10	2,00
7036 00 06	M 14	38	15	10	2,00

Bits (Supa-Pozidriv) Bits (Supa-Pozidriv)



7028 / 7038

Passend für Kreuzschlitzschrauben Supa-Pozidriv, für Maschinenschrauber und Handbetrieb, mit 1/4"-bzw. 5/16"-Außensechskant-Antrieb (6,3/8mm), Antrieb nach DIN 3126-C / ISO 1173-C, aus legiertem Sonderstahl, stahlgrau

For cross slot screws Supa Pozidriv, for use with air or electric power tools, with hexagon drive 1/4" or 5/16" (6.3/8mm), drive according to DIN 3126-C / ISO 1173-C, high grade tool steel, grey

Art.-Nr. / No.	PZ	mm	g	VE	EUR
1/4"					
7028 00 01	1	25	5	10	1,50
7028 00 02	2	25	5	10	1,50
7028 00 03	3	25	5	10	1,50
7028 00 04	4	25	5	10	1,50
5/16"					
7038 00 01	1	32	10	10	2,00
7038 00 02	2	32	10	10	2,00
7038 00 03	3	32	11	10	2,00
7038 00 04	4	38	14	10	2,00

Bits (5-Stern / IP-Profil) Bits (5-Star / IP Profile)



7029

Passend für Innen-5-Stern-Schrauben mit Zapfen (IP-Profil), für Lichtmaschine, Motorsteuerung, Luftmengenmesser, Türverkleidung usw. bei VW-Audi, Ford, Volvo, Mercedes Benz sowie Steckpumpen an Mercedes Benz Actros und Atego, mit 1/4"-Außensechskant-Antrieb (6,3mm), aus legiertem Sonderstahl, stahlgrau

For the operation of inside 5-star screws with pin, for dynamo, engine control, air flow sensor etc. on VW-Audi, Ford, Volvo, Mercedes Benz as well as for the screwed connection of the plug-in pump on Mercedes Benz Actros and Atego, high grade tool steel, grey

Art.-Nr. / No.	T	mm	g	VE	EUR
1/4"					
7029 00 01	10	25	5	10	4,20
7029 00 02	15	25	5	10	4,20
7029 00 03	20	25	5	10	4,20
7029 00 04	25	25	5	10	4,30
7029 00 05	27	25	5	10	4,30
7029 00 06	30	25	5	10	4,40
7029 00 07	40	30	5	10	4,50

Art.-Nr. / No.	Hex "	mm	g	VE	EUR	969
0969 20 50	1/4	230	205	5	9,95	Magazin-Bithalter, voll ummantelt, mit Magnet und 6 Bits aus S2-Spezialstahl Magazine Bit Holder, with strong permanent magnet and 6 bits, handle red P.P. Plastic, Bits: S2 Alloy Steel (25mm) Inhalt / content: 1,2x6,5x25mm PH 2 PH 3 TX 20 / 30 / 40

Magazin-Bithalter mit 6 Bits

Magazine Hand Driver with 6 Bits



Art.-Nr. / No.	Hex "	mm	g	VE	EUR	7047
7047 00 01	1/4	235	22	5	10,95	Magnet-Bithalter, mit 2-Komponenten-Griff, zur Aufnahme von 1/4"-Bits, Klinge verchromt, Chrom-Vanadium Magnet-Bitholder, with dual component handle, for 1/4"-drive bits, blade chrome plated, Chrome-Vanadium

Magnet-Bithalter 1/4"

Magnet-Bitholder 1/4"



Art.-Nr. / No.	g	VE	EUR	7049
7049 00 01	100	1	9,95	Bitbox, 20-teilig (nur Bitse), in patentierter Kunststoffdose, mit Gürtelclip, zum Aufklappen Bitbox, 20-pcs., only bits, with belt clip, in patented plastic box
7049 00 02	120	1	10,95	Bitbox, 17-teilig (Bitse und Bithalter 1/4"), in patentierter Kunststoffdose, mit Gürtelclip, zum Aufklappen Bitbox, 17-pcs. (bits and bitholder 1/4"), with belt clip, in patented plastic box

Bits Sortiment, 20- / 17-tlg.

Assortment of Bits, 20- / 17-pcs.



Art.-Nr. / No.	g	VE	EUR	7050
7050 00 01	370	1	32,95	Profi-Bit-Box, 31-tlg., in Metallkassette Professional Bitbox, 31-parts, in metal box Inhalt / content je / each 1x: 0,6x4,5 - 0,8x5,5 - 1,2x6,5 je / each 3x: PH 1, 2, 3 je / each 3x: PZ 1, 2, 3 je / each 1x: TX 10, 15, 20, 25, 30, 40 je / each 1x: Innensechskant / Hex 3mm, 4mm, 5mm

Bits Sortiment, 31-tlg.

Assortment of Bits, 31-pcs.

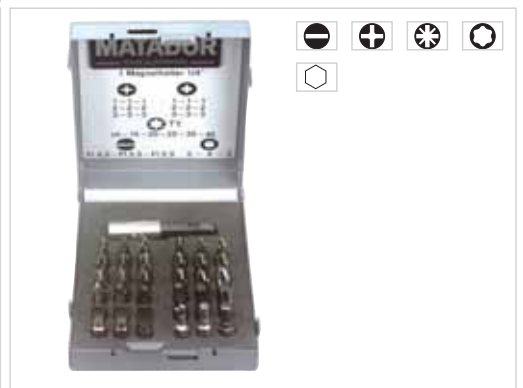

Schraubendreher-Bits / Screwdriver Bits

SUPER-TIN



MATADOR Super-TIN Bits mit einer 2-fachen Titan-Nitrit-Schicht erreichen eine Oberflächenhärte von 3.000 HV (normaler TIN-Bit ca. 2.500 HV). Durch ein spezielles Härte- und Anlaßverfahren erreicht der Bit eine Kernzähigkeit, die durch ein bis zu 30% höheres Drehmoment gegenüber unbeschichteten Bits nachgewiesen wird. Diese optimierte Kernzähigkeit und eine stärkere Verschleißschicht ergeben im Serieneinsatz höhere Standzeiten als bei einem normalen beschichteten TIN-Bit. Testen Sie selbst.

MATADOR Super-TIN bits have a surface hardness of 3,000 HV, which is obtained by a double titanium nitride coat (hardness of standard TIN bit approx. 2,500 HV). By applying an optimized multistage hardening and annealing process, the core tenacity is better than in case of uncoated bits. This reflects in a torque that is higher by 30%. The optimized core tenacity in combination with a thicker wearing protection coat ensures an extended service life in continuous operation, as compared with a TIN bit with standard coating. Try it out.

Super-TIN-Bits-Sortiment, 7-tlg. Assortment of TIN-Bits, 7-pcs.



7051

Art.-Nr. / No.



g VE EUR

Satz MATADOR Super-TIN Bits mit Profi-Magnethalter 1/4", in schwarzer Kunststoffbox

7051 00 01 7-tlg. / pcs.

95 1 14,95

Set of MATADOR Super-TIN bits with professional magnetic holder 1/4", in black plastic box

Inhalt / content:

je / each 1x: 0,8x5,5 - 1,2x6,5
je / each 1x: PH 1, 2
je / each 1x: PZ 1, 2
je / each 1x: Bithalter / Bitholder

Super-TIN-Bits, 31-tlg., TORX Assortment of TIN-Bits, 31-pcs.



7051

Art.-Nr. / No.



g VE EUR

Satz MATADOR Super-TIN Bits mit Profi-Magnethalter 1/4", in schwarzer Kunststoffbox

7051 00 02 31-tlg. / pcs.

370 1 45,95

Set of MATADOR Super-TIN bits with professional magnetic holder 1/4", in black plastic box

Inhalt / content:

je / each 1x: 0,6x4,5 - 0,8x5,5 - 1,2x6,5
je / each 3x: PH 1, 2, 3
je / each 3x: PZ 1, 2, 3
je / each 1x: TX 10, 15, 20, 25, 30, 40
je / each 1x: Innensechskant / Hexagon hollow screws 3mm, 4mm, 5mm

Maxi-TIN-Bits, 12-tlg. TORX Assortment of TIN-Bits, 12-pcs.



7051

Art.-Nr. / No.



g VE EUR

Satz MATADOR Super-TIN Bits "MaxiGrip" mit Profi-Magnethalter 1/4", in schwarzer Kunststoffbox

7051 00 03 12-tlg. / pcs.

170 1 35,95

Set of MATADOR Super-TIN bits "MaxiGrip" with professional magnetic holder 1/4", in black plastic box

Inhalt / content:

je / each 1x: TX 10, 2x TX 15, 2x TX 20,
2x TX 25, TX 27, 2x TX 30, TX 40
je / each 1x: Bithalter / Bitholder



Spezielle Sonderkeramikschrift. Der Bit krallt sich in die Schraube, bis zu 4-fach reduzierte Auswurfkraft im Vergleich zu Standard-Bits / Special ceramic coat. The bit grips into the screw, as compared with standard bits the ejection force is reduced more than 4 times

Art.-Nr. / No.		g	VE	EUR	ModuFlex 7052
7052 60 01	34-tlg. / pcs.	350	1	69,00	
Inhalt / content:					
- Mini-Umschaltknarre / Mini Ratchet 72T					
- Magnethalter für Bits / Magnetholder for bits					
- Adapter / Adaptors 1/4"-1/4" (6,3), 3/8"-1/4" (6,3), 3/8"-5/16" (8), 1/2"-5/16" (8)					
TORX-Bits:					
- 1/4" (25mm): TX 6, 7, 8, 9, 10, 15, 20					
- 5/16" (100mm): TX 25, 27, 30, 40, 45, 50, 55					
Tamper-TORX-Bits:					
- 1/4" (25mm): TX 6, 7, 8, 9, 10, 15, 20					
- 5/16" (100mm) : TX 25, 27, 30, 40, 45, 50, 55					

Kfz-Spezialsortiment, TORX / Tamper-TORX, mit feinverzahnter Mini-Umschaltknarre für besonders enge Zwischenräume (Einstecktiefe mit Bit nur 25,5mm!) sowie Bitadapter-Satz; Bits aus legiertem Sonderstahl, stahlgrau, mit MTS-Einlage in schwarzem Kunststoffkoffer, passt in alle MATADOR-Werkstattwagen

Automotive assortment with TORX / Tamper-TORX, with mini reversible ratchet for narrow spaces (insertion depth only 25,5mm!) and adaptor set; bits made of high grade tool steel, grey, with MTS-Module with black plastic case, fits into all MATADOR trolleys

MTS-Bitsortiment TORX
MTS Assortment of Bits TORX



Art.-Nr. / No.		g	VE	EUR	ModuFlex 7052
7052 60 02	27-tlg. / pcs.	350	1	79,00	
Inhalt / content:					
- Mini-Umschaltknarre / Mini Ratchet					
- 3/8"-Umschaltknarre / Reversible Ratchet 3061					
- Adapter / Adaptors 1/4"-1/4" (6,3), 3/8"-5/16" (8)					
- Tamper-TORX-Bits 1/4" (25mm): TX 9, 15, 25, 30					
- 5-Star-Bits 1/4" (25mm):					
T 10, 15, 20, 25, 27, 30, 40					
- XZN-Bits 1/4" (28mm): M 4, 5					
- XZN-Bits 5/16" (28mm): M 6, 8, 10, 12, 14					
- RIBE CV-Bits 5/16" (100mm): M 8, 10, 12, 14, 16					

Kfz-Spezialsortiment, 5-Stern / XZN / RIBE / Tamper-TORX, mit feinverzahnter Mini-Umschaltknarre für besonders enge Zwischenräume (Einstecktiefe mit Bit nur 25,5mm!), feinverzahnter 3/8"-Umschaltknarre, Bitadapter-Satz; Bits aus legiertem Sonderstahl, stahlgrau, mit MTS-Einlage in schwarzem Kunststoffkoffer, passt in alle MATADOR-Werkstattwagen

Automotive assortment with 5-star / XZN / RIBE / Tamper-TORX, with mini reversible ratchet for narrow spaces (insertion depth only 25,5mm!), 3/8"-72T-ratchet, adaptor set; bits made of high grade tool steel, grey, with MTS-Module with black plastic case, fits into all MATADOR trolleys

MTS-Bitsortiment 5-Stern/XZN/RIBE
MTS Assortment of Bits 5-star / XZN



Art.-Nr. / No.		g	VE	EUR	7052
7052 00 02	31-tlg. / pcs.	95	1	24,95	
Inhalt / Content:					
- 1/4"-Mini-Umschaltknarre, feinverzahnt, 92mm					
1/4"-Mini Ratchet, 72T, 92mm					
- Bit-Adapter für Bohrmaschine					
- Bits PH 1, 2, 3, 4; PZ 1, 2, 2, 3;					
Schlitz / Slotted 3, 4, 5, 6;					
Innensechskant / Hex 3, 4, 5, 6;					
TORX TX 10, 15, 20, 25, 27, 30, 40;					
Tamper-TORX TX 10, 15, 20, 25, 27, 30, 40					

Mini-Sortiment, TORX / Tamper-TORX, mit feinverzahnter Mini-Umschaltknarre für besonders enge Zwischenräume (Einstecktiefe mit Bit nur 25,5mm!) Bits aus legiertem Sonderstahl, stahlgrau, in Kunststoffbox mit Gürtelclip

Assortment with TORX / Tamper-TORX, with mini reversible ratchet for narrow spaces (insertion depth only 25,5mm!), adaptor; bits made of high grade tool steel, grey, in plastic box with belt clip

Bitsortiment TORX
Assortment of Bits TORX



Feinverzahnt / 72 T



Nur 25mm Tiefe inkl. Bit / Only 25mm depth with bit

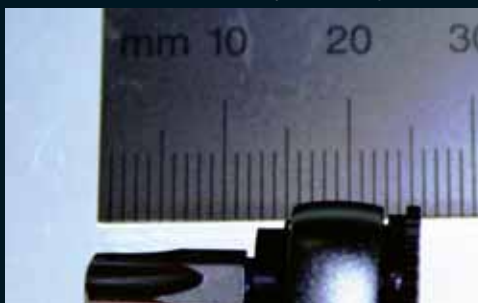

Verlängerbar mit Adapter / Extendable with adaptor



Schlagwerkzeuge	Punching Tools
Abzieher	Pullers
Schneidwerkzeuge	Cutting Tools
Messwerkzeuge	Measuring Tools
Verschiedenes	Miscellaneous

Abzieher	Arch Punches
Bohrer	Ball Joint Pullers
Diverse Werkzeuge	Chisels
Drehmomentschlüssel	Drills
Feilen	Files
Fettpressen	Grease Guns
Gewindereparatursätze	Hacksaws
Hämmer	Hammers
Henkellocheisen	Internal Pullers
Innenausdreher	Knifes
Kugelgelenk-Ausdrücker	Letter / Figure Steel Stamp Sets
Magnetheber	Miscellaneous Tools
Meißel / Durch- und Splinttreiber	Pick Up Tools
Messer	Pipe Cutter
Rohrabschneider	Pullers
Sägen	Scraper
Schaber	Screw Extractors
Schlagbuchstaben / -ziffern	Thread Repair Sets
Schraubenausdreher	Torque Wrenches
Schraubstöcke	Vices



Inhalt Index

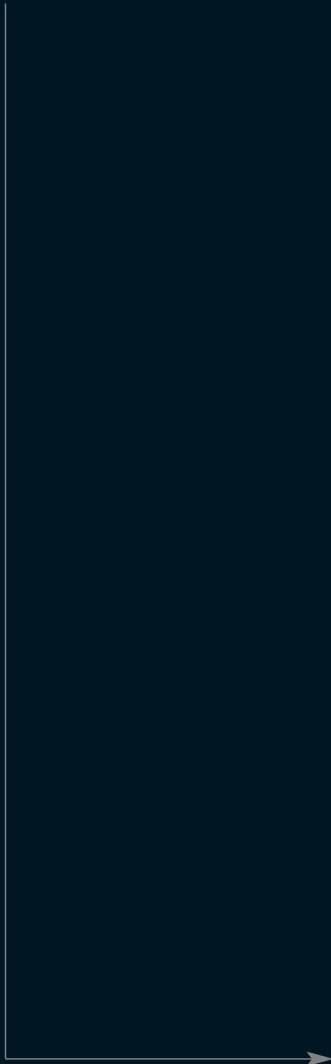

Allgemeine Werkzeuge
Miscellaneous

Schlagwerkzeuge / Punching Tools

Kunststoff-Treib-/Ausbeulhämmer Soft Faced Hammers



700

Mit Eschenstiel, auswechselbare Schlagköpfe aus transparentem Kunststoff (Celluloseacetat)

Ash handle, with replaceable faces made from transparent plastic (cellulose acetate)

Ersatzschlagköpfe, paarweise (vor der Montage erwärmen)

Pair of Spare Heads (to be warmed before assembly)

Art.-Nr. / No.	∅ mm	↔ mm	⚖ g	📦 VE	EUR
0700 00 01	22	250	150	6	6,95
0700 00 02	27	280	230	6	7,95
0700 00 03	32	285	350	6	8,95
0700 00 04	35	300	430	6	11,95
0700 00 05	40	320	640	2	13,95
0700 00 06	50	340	1000	2	21,95
0701 00 01	22		30	6	0,95
0701 00 02	27		30	6	0,95
0701 00 03	32		35	6	1,50
0701 00 04	35		60	6	1,80
0701 00 05	40		65	2	2,10
0701 00 06	50		130	2	3,95

Rückschlagfreie Schonhämmer Non-rebound Nylon Hammers



702

Rückschlagfreie Schonhämmer mit Hickorystiel; für rückschlagfreie Schläge ohne Schlagverlust durch Schrotfüllung im Gehäuse, ideal für Arbeiten auf Maschinentischen, u. a. Montage-/Reparaturarbeiten im Kfz-Bereich, Positionieren von Werkstücken im Schraubstock usw.

With Hickory handle, replaceable nylon faces, hollow head partially filled with steel shot to prevent rebound at full striking power

Ersatzschlagköpfe (einzeln) / Spare nylon faces (single)

Art.-Nr. / No.	∅ mm	↔ mm	⚖ g	📦 VE	EUR
0702 00 01	25	305	300	1	34,95
0702 00 02	30	330	430	1	36,20
0702 00 03	35	335	550	1	39,90
0702 00 04	40	360	750	1	45,70
0702 00 05	50	370	1000	1	57,90
0702 00 10	25			1	4,00
0702 00 20	30			1	4,50
0702 00 30	35			1	5,30
0702 00 40	40			1	6,30
0702 00 50	50			1	8,10

Schlosserhämmer Engineers Hammers



705



DIN 1041, deutsche Form, mit Eschenstiel nach DIN 5111, pulverbeschichtet, Arbeitsfläche poliert, Bahn und Pinne geschliffen

DIN 1041, German pattern, ash handle, powder painted, working face polished, face and pein grinded

Eschenstiel, DIN 5111 / Ash Handles

Ringkeile für Eschenstiele / Metall rings for Ash Handle

Art.-Nr. / No.	📏 g	⚖ g	📦 VE	EUR	
0705 00 02	200	245	6	7,95	
0705 00 03	300	360	6	9,95	
0705 00 04	400	490	6	10,50	
0705 00 05	500	600	6	10,95	
0705 00 07	800	960	2	16,95	
0705 00 08	1000	1135	2	17,95	
0705 00 09	1500	1690	2	25,95	
0705 00 10	2000	2250	1	29,95	
0706 00 02	200	45	6	2,10	
0706 00 03	300	60	6	2,25	
0706 00 04	400	90	6	2,40	
0706 00 05	500	100	6	2,50	
0706 00 07	800	160	2	2,80	
0706 00 08	1000	135	2	2,95	
0706 00 09	1500	190	2	3,30	
0706 00 10	2000	250	1	3,80	
0706 00 21	200		1	6	1,00
0706 00 31	300		2	6	1,00
0706 00 41	400		3	6	1,00
0706 00 51	500		4	6	1,00
0706 00 71	800		7	2	1,00
0706 00 81	1000		8	2	1,00
0706 00 91	1500		8	2	1,00
0706 01 01	2000		11	2	1,00

Art.-Nr. / No.	 g	 g	 VE	EUR	706
0706 10 30	300	350	1	9,90	<p>Mit (fast) unzerbrechlichem Fiberglasstiel, rutschfest mit dem Kopf vergossen, Handgrifffläche mit rutschfestem Gummibelag, Kopf gehärtet, Bahn und Pinne geschliffen</p> <p>Forged from fine grain carbon steel, correctly hardened and tempered with a black painted head, fibreglass shaft fitted with comfortable shock-absorbing rubber grip, face and pein grinded</p>
0706 10 50	500	550	1	12,50	
0706 10 80	800	880	1	16,80	

Hämmer mit Fiberglasstiel

Hammer with Fibreglass Shaft







Art.-Nr. / No.	 kg	 mm	 g	 VE	EUR	707
0707 10 00	1	260	1180	1	13,90	<p>DIN 6475, mit angeschmiedetem Stielschutzkragen und Nylonschutzhülse, mit Eschenstiel, Kopf ring verkeilt</p> <p>With safety forged collar, nylon protection, ash shaft, fixed with round wedge and red epoxy resin</p>
0707 15 00	1,5	290	1690	1	17,50	
0707 20 00	2	300	2200	1	19,95	

Fäustel

Club Hammers







Art.-Nr. / No.	 lbs	 mm	 g	 VE	EUR	710
0710 00 01	1/4	250	170	6	12,90	<p>Englische Form, schwarz lackiert, Bahn und Kugel-pinne geschliffen, mit Eschenstiel</p>
0710 00 02	1/2	295	310	6	13,90	
0710 00 03	3/4	315	450	6	14,90	<p>English pattern, black laquered, ball pein and face ground, with ash shaft</p>
0710 00 04	1	335	555	6	15,90	
0710 00 06	1.1/2	365	825	2	16,90	
0710 00 08	2	375	1025	2	17,90	

Schlosserhämmer

Ball Pein Hammers



Art.-Nr. / No.	 mm	 mm	 g	 VE	EUR	738
0738 00 01	55 x 90	320	300	1	7,50	<p>DIN 5128 A, mit zwei flachen Bahnen, mit Eschenstiel</p> <p>DIN 5128 A, with two flat faces, with ash shaft</p>
0738 00 02	65 x 115	340	520	1	9,20	
0738 00 03	75 x 130	360	750	1	13,90	
0738 00 04	90 x 140	380	1130	1	17,50	
0738 00 05	65 x 115	340	520	1	9,50	<p>DIN 5128 B, eine gerade und eine gewölbte Bahn, mit Eschenstiel</p> <p>DIN 5128 B, one flat and one curved face, with ash shaft</p>

Gummihämmer

Rubber Mallets



Schlagwerkzeuge / Punching Tools

Schlagbuchstaben-Sätze Letter Steel Stamp Sets



712

DIN 1451, 27 Großbuchstaben: "A-Z" und "&" zum Einschlagen in Stahl, in stabiler Kunststoffdose
DIN 1451, 27 capital letters "A-Z" and "&" for marking in steel, in solid plastic box

Art.-Nr. / No.	mm	mm	g	VE	EUR
0712 10 40	4	7x65	670	1	27,95
0712 10 50	5	8x65	865	1	30,50
0712 10 60	6	9x70	1180	1	33,50
0712 10 80	8	11x75	1895	1	49,00

Schlagziffern-Sätze Figure Steel Stamp Sets



712

DIN 1451, 9 Ziffern: "0-9" zum Einschlagen in Stahl, in stabiler Kunststoffdose
DIN 1451, 9 figures "0-9" for marking in steel, in solid plastic box

Art.-Nr. / No.	mm	mm	g	VE	EUR
0712 00 40	4	7x65	230	1	9,30
0712 00 50	5	8x65	295	1	10,15
0712 00 60	6	9x70	400	1	11,20
0712 00 80	8	11x75	635	1	15,50

Henkellocheisen Arch Punches



713

DIN 7200 A, gehärtete Schneide, Pfeife blank geschliffen, Schaft lackiert, aus Spezialstahl, zum Ausstanzen von weichen Werkstoffen, ideal für Brandflecken im Teppich, Untersetzer aus Filz oder Kork usw.
DIN 7200 A, cutting edges hardened, pipe grinded, shaft laquered, special steel, for leather, carton, rubber and other soft materials, perfect for punching carpets after cigarette fire etc.

8-tlg.-Satz in Rolltasche / 8-pcs. Set in rollbag

Art.-Nr. / No.	mm	mm	g	VE	EUR
0713 00 10	2	105	40	10	4,10
0713 00 20	3	105	40	10	4,10
0713 00 30	4	105	48	10	4,10
0713 00 40	5	110	55	10	4,10
0713 00 50	6	110	68	10	4,40
0713 00 60	7	120	80	10	4,40
0713 00 80	8	120	85	10	4,40
0713 00 90	9	120	90	10	4,40
0713 01 00	10	130	120	10	4,90
0713 01 10	11	130	120	10	6,20
0713 01 20	12	130	120	10	6,20
0713 01 30	13	140	155	10	7,20
0713 01 40	14	140	160	5	7,20
0713 01 50	15	140	160	10	7,50
0713 01 60	16	140	170	5	8,70
0713 01 70	17	145	205	10	8,70
0713 01 80	18	145	210	10	8,90
0713 01 90	19	145	210	10	9,50
0713 02 00	20	160	300	5	11,50
0713 02 22	22	160	300	10	12,50
0713 02 25	25	170	355	10	14,50
0713 03 00	30	190	560	10	18,50

Ideal bei Brandflecken - einfach ausstanzen / Perfect for removing fire spots in carpets - just punch it



0713 05 00	3, 6, 8, 10 12, 16, 20 25mm		1475	1	39,90
------------	-----------------------------------	--	------	---	-------

Art.-Nr. / No.	↔ mm	⚖️ 📦 g VE		EUR	714
		g	VE		
0714 00 01	125 x 15	100	10	4,30	DIN 6453 A, Schlagköpfe vergütet, lackiert, Schneide geschliffen, Chrom-Vanadium-Stahl 59 CrV 4 (W-Nr. 1.2242) DIN 6453 A, lacquered, Chrome Vanadium steel 59 CrV 4 (1.2242)
0714 00 02	150 x 18	180	10	5,70	
0714 00 03	175 x 21	250	10	6,40	
0714 00 04	200 x 24	400	10	7,50	
0714 00 05	250 x 27	550	5	8,90	
0714 00 06	300 x 27	700	5	10,90	

Flachmeißel Flat Cold Chisels



Art.-Nr. / No.	↔ mm	⚖️ 📦 g VE		EUR	714
		g	VE		
0714 00 12	125 - 250	1500	1	33,95	5-teiliger Satz in Tasche, DIN 6453 A, Schlagköpfe vergütet, lackiert, Schneide geschliffen, Chrom-Vanadium-Stahl 59 CrV 4 (W-Nr. 1.2242) 5-pcs. set in wallet, DIN 6453 A, lacquered, Chrome Vanadium steel 59 CrV 4 (1.2242)

Flachmeißel-Satz Flat Cold Chisel-Set



Art.-Nr. / No.	↔ mm	⚖️ 📦 g VE		EUR	715
		g	VE		
0715 00 01	125 x 5	95	10	4,50	DIN 6451 A, Schlagköpfe vergütet, lackiert, Schneide geschliffen, Chrom-Vanadium-Stahl 59 CrV 4 (W-Nr. 1.2242) DIN 6451 A, lacquered, Chrome Vanadium steel 59 CrV 4 (1.2242)
0715 00 02	150 x 6	160	10	5,50	
0715 00 03	175 x 7	230	10	5,90	
0715 00 04	200 x 8	310	10	8,50	
0715 00 05	250 x 9	400	5	10,80	

Kreuzmeißel Cross Cut Chisels



Art.-Nr. / No.	↔ mm	⚖️ 📦 g VE		EUR	715
		g	VE		
0715 00 12	125 - 250	1400	1	32,00	5-teiliger Satz in Tasche, DIN 6451 A, Schlagköpfe vergütet, lackiert, Schneide geschliffen, Chrom-Vanadium-Stahl 59 CrV 4 (W-Nr. 1.2242) 5-pcs. set in wallet, DIN 6451 A, lacquered, Chrome Vanadium steel 59 CrV 4 (1.2242)

Kreuzmeißel-Satz Cross Cut Chisel-Set



Schlagwerkzeuge / Punching Tools

Durchtreiber Drift Punches



716

DIN 6458 D, Treibkopf und -fläche geschliffen, mit 8-kant-Schaft, lackiert, Chrom-Molybdän-Stahl 45 CrMoV 7 (W.-Nr. 1.2328)

DIN 6458 D, taper section ground, with octogonal shape, lacquered, Chrome-Molybdenum Steel CrMoV 7 (1.2328)

Art.-Nr. / No.	∅ mm	↔ mm	⚖ g	📦 VE	EUR
0716 00 01	3	120	90	10	2,50
0716 00 02	4	120	90	10	2,50
0716 00 03	5	120	90	10	2,50
0716 00 04	6	120	90	10	2,50
0716 00 05	8	120	120	10	2,50
0716 00 07	10	150	120	10	2,90

Durchtreiber-Satz Drift Punch-Set



716

6-teiliger Satz in Plastikständer, DIN 6458 D, Treibkopf und -fläche geschliffen, mit 8-kant-Schaft, lackiert, Chrom-Molybdän-Stahl 45 CrMoV 7 (W.-Nr. 1.2328)

6-pcs. set in plastic bench stand, DIN 6458 D, taper section ground, with octogonal shape, lacquered, Chrome-Molybdenum Steel CrMoV 7 (1.2328)

Art.-Nr. / No.	∅ mm	⚖ g	📦 VE	EUR
0716 00 12	3, 4, 5, 6, 8, 10	640	1	15,90

Körner Centre Punch



717

DIN 7250, Kegel und Spitze geschliffen, mit 8-kant-Schaft, lackiert, Chrom-Molybdän-Stahl 45 CrMoV 7 (W.-Nr. 1.2328)

DIN 7250, taper section ground, with octogonal shape, lacquered, Chrome-Molybdenum Steel CrMoV 7 (1.2328)

Art.-Nr. / No.	↔ mm	⚖ g	📦 VE	EUR
0717 00 01	120 x 4	90	10	2,50
0717 00 02	120 x 5	100	10	2,90

Splinttreiber Parallel-Pin Punches



718

DIN 6450 C, Treibkopf und -fläche geschliffen, mit 8-kant-Schaft, lackiert, Chrom-Molybdän-Stahl 45 CrMoV 7 (W.-Nr. 1.2328)

DIN 6450 C, taper section ground, with octogonal shape, lacquered, Chrome-Molybdenum Steel CrMoV 7 (1.2328)

Art.-Nr. / No.	∅ mm	↔ mm	⚖ g	📦 VE	EUR
0718 00 01	2	150	55	10	3,50
0718 00 02	3	150	60	10	3,50
0718 00 03	4	150	65	10	3,50
0718 00 04	5	150	70	10	3,50
0718 00 05	6	150	80	10	3,50
0718 00 06	8	150	100	10	3,70
0718 00 07	10	150	120	10	3,90

Art.-Nr. / No.	∅ mm	↔ mm	⚖ g	📦 VE	EUR	718
0718 00 12	2,3,4, 5,6,8	150	500	1	19,95	<p>6-tlg.-Satz in Plastikständer, DIN 6450 C, Treibkopf und -fläche geschliffen, mit 8-kant-Schaft, lackiert, Chrom-Molybdän-Stahl 45 CrMoV 7 (W.-Nr. 1.2328)</p> <p>6-pcs. set in plastic stand bench, DIN 6450 C, taper section ground, with octagonal shape, lacquered, Chrome-Molybdenum Steel CrMoV 7 (1.2328)</p>

Splinttreiber-Satz Parallel-Pin Punch-Set



Art.-Nr. / No.	∅ mm	↔ mm	⚖ g	📦 VE	EUR	718
0718 00 10	2,3,4, 5,6,8	150	800	1	29,95	<p>6-tlg.-Satz in klappbarer Metallkassette, DIN 6450 C, Treibkopf und -fläche geschliffen, mit 8-kant-Schaft, lackiert, Chrom-Molybdän-Stahl 45 CrMoV 7 (W.-Nr. 1.2328)</p> <p>6-pcs. set in hinged metal box, DIN 6450 C, taper section ground, with octagonal shape, lacquered, Chrome-Molybdenum Steel CrMoV 7 (1.2328)</p>

Splinttreiber-Satz Parallel-Pin Punch-Set



Art.-Nr. / No.	⚖ g	📦 VE	EUR	719
0719 00 02	500	1	22,95	<p>6-teilig, mit Meißeln, Splint- und Durchtreibern sowie Körner, in Plastikständer</p> <p>6-pcs., in plastic bench stand</p> <p>Inhalt / Contents:</p> <p>714 125 x 15, 150 x 15mm 715 125 x 5mm 716 3, 4mm 717 120 x 4mm</p>

Werkzeugsatz, 6-tlg. Chisel and Punch Set, 6-pcs.



Art.-Nr. / No.	⚖ g	📦 VE	EUR	719/3
0719 00 03	3500	224,00	<p>90-teilig, mit Flachmeißeln, Splint- und Durchtreibern sowie Körner, in Acrylglasständer</p> <p>90-pcs., with flat cold chisels, drift punches, centre punches and parallel-pin punches, in plastic bench stand</p>	

Inhalt / content		
714	125 x 15mm	6x
	150 x 18mm	6x
716	3, 4, 5, 6, 8, 10mm	6x
717	120 x 4mm	6x
	120 x 5mm	6x
718	2, 3, 4, 5, 6mm	6x

Werkzeugsatz im Verkaufsständer Chisel and Punch Dispenser Unit



Abzieher / Pullers

Abzieher, 2-armig Pullers, 2 legs



724/1

Schwere Ausführung, höhenverstellbare Haken, zweiseitig verwendbar (eine Seite mit breiten, andere Seite mit schmalen Haken), Laschenkonstruktion presst Haken nach innen, zum Abziehen von Kugellagern, Zahnrädern usw., verzinkt

Heavy-duty pattern, puller legs to be used on both sides: one side with wide, the other side with narrow hooks, for pulling off ball bearings, gears, zinc plated

Art.-Nr. / No.	mm	mm	kg	VE	EUR
0724 00 01	150	85	0,8	1	65,80
0724 00 02	200	130	2	1	89,50

Abzieher, 2-armig Pullers, 2 legs



724/10

Schwere Ausführung, große Spannweite, höhenverstellbare Haken, Laschenkonstruktion presst Haken nach innen, verzinkt

Heavy-duty pattern, wide spread, zinc plated

Art.-Nr. / No.	mm	mm	kg	VE	EUR
0724 00 10	300	250	5	1	135,50
0724 00 11	400	400	6,1	1	159,50

Universalabzieher, 2-armig Universal Pullers, 2 legs



726/1

Haken sind umsteckbar für Außen- und Innenspannung, verschieden lang für jede erforderliche Spanntiefe, greifen parallel und sind auf der Brücke klemmbar, mit schmalen und spitzem Hakenfuß für enge Zwischenräume, verzinkt

Universally applicable, with interchangeable arms for any required reach, serve both as outside and inside pullers, legs are always gripping parallel, puller legs with narrow hooks for confined spaces

Art.-Nr. / No.	mm	mm	kg	VE	EUR
0726 00 01	80	100	1,2	1	75,80
0726 00 02	130	100	1,4	1	79,90
0726 00 03	160	150	3,5	1	125,50
0726 00 04	200	150	4	1	138,00
0726 00 05	250	200	8	1	215,80
0726 00 06	350	200	10	1	245,30

Krallex-Universalabzieher, 2-armig Krallex-Universal Pullers, 2 legs



726/10

Mit extra dünnen Haken, Haken sind umsteckbar für Außen- und Innenspannung, verschieden lang für jede erforderliche Spanntiefe, greifen parallel und sind auf der Brücke klemmbar, mit schmalen und spitzem Hakenfuß für enge Zwischenräume, verzinkt

Leg tip extrem flat; leg body extremely narrow, serve both as outside and inside pullers, legs are always gripping parallel

Nachrüsthinweis: extra dünne Haken für zweiarmige, parallelgreifende Abzieher (1 Paar) in Standardlängen erhältlich / Spare extra flat legs for two-arm pullers, standard length (Set = 2 pieces)

Art.-Nr. / No.	mm	mm	kg	VE	EUR
0726 00 10	100	20-80	1,0	1	79,50
0726 00 11	100	20-130	1,2	1	88,50
0726 00 13	150	60-200	3,2	1	158,00

0726 05 10 1)	100		0,5	1	45,50
0726 05 11 2)	150		1,2	1	59,50

- 1) Haken passend für / Legs suitable for nos. 0726 00 10, 0726 00 11
- 2) Haken passend für / Legs suitable for nos. 0726 00 13

Art.-Nr. / No.	725/1				
	mm	mm	g	VE	EUR
0725 00 01	150	85	1100	1	74,50
0725 00 02	200	130	2700	1	128,90

Schwere Ausführung, höhenverstellbare Haken, zweiseitig verwendbar (eine Seite mit breiten, andere Seite mit schmalen Haken), Laschenkonstruktion presst Haken nach innen, zum Abziehen von Kugellagern, Zahnrädern usw., verzinkt

Heavy-duty pattern, puller legs to be used on both sides: one side with wide, the other side with narrow hooks, for pulling off ball bearings, gears, zinc plated

Abzieher, 3-armig Pullers, 3 legs



Art.-Nr. / No.	725/10				
	mm	mm	g	VE	EUR
0725 00 10	300	250	7000	1	138,90
0725 00 11	400	400	8800	1	168,50

Schwere Ausführung, große Spannweite, höhenverstellbare Haken, Laschenkonstruktion presst Haken nach innen, verzinkt

Heavy-duty pattern, wide spread, zinc plated

Abzieher, 3-armig Pullers, 3 legs



Art.-Nr. / No.	725/21				
	mm	mm	g	VE	EUR
0725 00 21	100	25-130	1,6	1	109,70
0725 05 20	100		0,9	3	58,00

Haken sind umsteckbar für Außen- und Innenspannung, verschieden lang für jede erforderliche Spanntiefe, greifen parallel und sind auf der Brücke klemmbar, mit schmalen und spitzem Hakenfuß für enge Zwischenräume, verzinkt

Universally applicable, with interchangeable arms for any required reach, serve both as outside and inside pullers, legs are always gripping parallel, puller legs with narrow hooks for confined spaces

Ersatzhaken / Spare legs

Universal-Abzieher, 3-armig Universal Pullers, 3 legs



Art.-Nr. / No.	725/31				
	mm	mm	g	VE	EUR
0725 00 31	100	25-130	1,6	1	115,90
0725 05 30	100		0,9	3	58,00

Mit extra dünnen Haken, Haken sind umsteckbar für Außen- und Innenspannung, verschieden lang für jede erforderliche Spanntiefe, greifen parallel und sind auf der Brücke klemmbar, mit schmalen und spitzem Hakenfuß für enge Zwischenräume, verzinkt

Leg tip extrem flat; leg body extremely narrow, serve both as outside and inside pullers, legs are always gripping parallel

Ersatzhaken / Spare legs

Krallex-Universal-Abzieher, 3-armig Krallex-Universal Pullers, 3 legs



Abzieher / Pullers

Krallex-Universalabzieher, 2-armig Krallex-Universal Pullers, 2 legs



726/50

Universalabzieher, 2-armig, 3 Abzieher in einem, schlank geschmiedete Haken, für schwer zugängliche Stellen, Spannweite 20-130mm

Universal Puller, 2 arms, 3 pullers in one, slim forged hooks, max. range 20-130mm

Ersatzhaken / Spare legs
Ersatzspindel / Spare spindle

Art.-Nr. / No.	mm	kg	VE	EUR
----------------	----	----	----	-----

0726 00 50	100/200/250	3,31	1	245,80
------------	-------------	------	---	--------

0726 00 51			1	16,50
0726 00 52			1	21,50

Satz Krallex-Universalabzieher Set of Krallex-Universal Pullers



726/100

2- und 3-armig, mit Schnellspannmutter, mit extra dünnen Haken (2,0mm), Haken sind umsteckbar für Außen- und Innenspannung, verschieden lang für jede erforderliche Spanntiefe, greifen parallel und sind auf der Brücke klemmbar, verzinkt, in schwarzem Kunststoffkoffer

2 and 3 legs, with quick-release fastener, leg tip extrem flat; leg body extremely narrow (2.0mm), serves both as outside and inside pullers, legs are always gripping parallel, in black plastic case

Art.-Nr. / No.	mm	mm	kg	VE	EUR
----------------	----	----	----	----	-----

0726 01 00	100	20-90	1,0	1	145,00
0726 01 11	100	25-130	1,2	1	154,00

Abzieher mit Trennmesser Separators with Pulling Device



727

Zum Abziehen von dicht aufsitzenden Teilen:
- Trennmesser durch gleichmäßiges, wechselseitiges Anziehen der Muttern hinter das abzuziehende Teil keilen
- die Zugstange des Abziehers 727 in die Adapter-Gewinde des Trennmessers schrauben
- Spindel des Abziehers 727 einschrauben

Instructions for use:
- Tapered knife edges of separator fit behind bearings to be removed by tightening stud nuts
- Turn tie rods of device into adapter thread of separator
- Screw in spindle of device

Art.-Nr. / No.	mm	mm	kg	VE	EUR
----------------	----	----	----	----	-----

Trennmesser / Separator:					
0727 00 20		15-75	0,7	1	79,50
0727 00 30		35-115	1,7	1	118,30

Abzieher / Pulling Devices:					
0727 00 50 1)	150	45-130	1,0	1	92,30
0727 00 60 2)	210	55-205	3,3	1	139,40

1) passend für Nr. / Legs suitable for nos.
0727 00 20, 0727 00 30
2) passend für Nr. / Legs suitable for no.
0727 00 30

Polklemmenabzieher, 2-armig Battery Terminal Pullers, 2 legs



728

Zum Abziehen kleiner Teile wie festsitzender Batterieklemmen, Scheiben, Räder, Kugellager, selbsttätiges Anpressen der Haken

For pulling off battery terminals, ball bearings

Art.-Nr. / No.	mm	mm	kg	VE	EUR
----------------	----	----	----	----	-----

0728 00 01	50	40	0,19	1	29,30
0728 00 02	70	65	0,30	1	35,70

Art.-Nr. / No.	A		B		C		g	VE	EUR	729
	mm	mm	mm	mm	mm	mm				
0729 00 01	18	40	35	375	1	38,50				
0729 00 02	25	50	45	600	1	52,70				
0729 00 03	29	60	55	900	1	64,30				
0729 00 04	40	80	80	2200	1	81,80				

A = Gabelöffnung / jaw opening
 B = max. Spannhöhe / max. clear height
 C = Breite / Width

Zum Ausdrücken der Kugelgelenkzapfen an Spurstangen und Stabilisatoren, verzinkt

For removal of ball pivots on tie-rods and stabilizers, zinc plated

Kugelgelenk-Ausdrücker Ball Joint Pullers



Art.-Nr. / No.	A		B		g	VE	EUR	731/4
	mm	mm	mm	mm				
0731 00 04	23	55	800	1	55,00			
0731 00 05	28	55	800	1	75,00			
0731 00 06	34	63	900	1	85,00			

A = Gabelöffnung / jaw opening
 B = max. Spannhöhe / max. clear height

Für Transporter / for vans and commercial vehicles

Zum Ausdrücken der Kugelgelenkzapfen an Spurstangen und Stabilisatoren, nur 6mm Greifkantenhöhe, extrem schmal für enge Zwischenräume, auch für Aluminium-Fahrwerke, für fast alle Fahrzeugtypen einsetzbar

For removal of ball pivots on tie-rods and stabilizers, only 6mm height of jaw, very slim, also for carriages made from aluminium, for nearly all passenger cars

Kugelgelenk-Ausdrücker, schmal Ball Joint Pullers, slim type



Art.-Nr. / No.	g	VE	EUR	731/100
0731 01 00	3-tlg. / pcs.	800	1	195,00

Inhalt / content:
0731 00 04
0731 00 05
0731 00 06

3-tlg. Satz, zum Ausdrücken der Kugelgelenkzapfen an Spurstangen und Stabilisatoren, nur 6mm Greifkantenhöhe, extrem schmal für enge Zwischenräume, auch für Aluminium-Fahrwerke, für fast alle Fahrzeugtypen einsetzbar, in schwarzem Kunststoffkoffer

3-pcs. set, for removal of ball pivots on tie-rods and stabilizers, only 6mm height of jaw, very slim, also for carriages made from aluminium, for nearly all passenger cars, in black plastic case

Kugelgelenk-Ausdrücker, 3-pcs. Ball Joint Pullers, 3-pcs., slim



Art.-Nr. / No.	A		B		g	VE	EUR	731/1
	mm	mm	mm	mm				
0731 00 01	18-22	55	700	1	65,20			

A = Gabelöffnung / jaw opening
 B = max. Spannhöhe / max. clear height

Für PKW + LKW, zum Ausdrücken der Kugelgelenkzapfen an Lenkhebeln, Spurstangen, Achsschenkeln, Stabilisatoren etc., großer Spannbereich durch stufenlose Höhenverstellung und Wenden des Unterteils

For passenger cars and trucks, for removal of ball pivots on tie-rods and stabilizers, max. capacity up to 50 mm by reversing the bottom part, wide clamping range due to infinite variability

Universal-Kugelgelenk-Ausdrücker Universal Ball Joint Puller



Abzieher / Pullers

Universal-Kugelgelenk-Ausdrücker Universal Ball Joint Puller



731/2

Für PKW + LKW, zum Ausdrücken der Kugelgelenkzapfen an Lenkhebeln, Spurstangen, Achsschenkeln, Stabilisatoren etc., Maulöffnung 20-22, Spannungsbereich 2-stufig (bis 30mm und bis 50mm), Länge 170mm

For passenger cars and trucks, for removing the ball joint pivots of steering tie rods, stabilizers, etc., span of jaw 20-22mm, clamping range in 2 stages (to 30mm and to 50mm)

Art.-Nr. / No.	A mm	B mm	g	VE	EUR
----------------	------	------	---	----	-----

0731 00 02	20-22	50	1300	1	88,30
------------	-------	----	------	---	-------

A = Gabelöffnung / jaw opening
B = max. Spannungshöhe / max. clear height

Kugelgelenk-Ausdrücker, für LKW Ball Joint Pullers, for trucks



731/9

Für mittelschwere LKW, z.B. für MB ATEGO bis 17to, MAN, IVECO, RENAULT, SCANIA, VOLVO, DAF

For medium trucks, e.g. MB ATEGO up to 17to, MAN, IVECO, RENAULT, SCANIA, VOLVO, DAF

Art.-Nr. / No.	A mm	B mm	g	VE	EUR
----------------	------	------	---	----	-----

0731 00 09	27-36	90	3700	1	135,20
------------	-------	----	------	---	--------

A = Gabelöffnung / jaw opening
B = max. Spannungshöhe / max. clear height

Kugelgelenk-Ausdrücker, für LKW Ball Joint Pullers, for trucks



731/10

Für schwere LKW, z.B. für DB Actros, Atego ab 18to, SK MAN F 2000, TGA / TGM, Niederflur-Stadtbus, IVECO, Renault, Scania, Volvo, DAF

For heavy-duty trucks, e.g. MB ATEGO over 18to, SK MAN F 2000, TGA / TGM, Niederflur-Stadtbus, IVECO, Renault, Scania, Volvo, DAF

Art.-Nr. / No.	A mm	B mm	g	VE	EUR
----------------	------	------	---	----	-----

0731 00 10	35-45	115	6500	1	295,10
------------	-------	-----	------	---	--------

A = Gabelöffnung / jaw opening
B = max. Spannungshöhe / max. clear height

Trenngabeln Separators



731/17

Zum Lösen von Spurstangenköpfen, Stoßdämpfern, Lenkstockhebeln usw., Gelenkkopf massiv, Haltestange am Griff gerändelt, Gesamtlänge 330mm

For removing ball joints at tracking levers, shock absorbers and steering mechanism, fork with strong rod handle, total length 330mm

Art.-Nr. / No.	A mm	B mm	g	VE	EUR
----------------	------	------	---	----	-----

0731 00 17	18	16-18	900	1	47,30
0731 00 18	23	19-23	900	1	51,50
0731 00 19	31	24-31	1100	1	54,70

A = Gabelöffnung / jaw opening
B = Zapfendurchmesser / pin diameter

Art.-Nr. / No.	mm	g	VE	EUR	731/200
0731 02 00	10-37	3300	1	279,00	
<p>Inhalt / content:</p> <ul style="list-style-type: none"> - Innenausdreher / Internal Pullers 10-13, 14-19, 20-25, 25-30, 30-37mm - Schlagauszieher / Slide Hammer - Gegenstützen / Counter Stays 					
<p>7-tlg.-Satz, zum Ausziehen von Kugellagern, Kugellager-Außenringen und Büchsen, mit geschlitztem, vierteiligem Schaft, gleichmäßig radial spreizbare Segmente für präzises, sicheres und schonendes Ausziehen zusammen mit Gegenstütz-Vorrichtung und Schlagauszieher, in schwarzem Metallkasten</p> <p>7-pcs. set, for extracting ball bearings, outer rings and bushings, to be used with counter stays and slide hammer, in black metal case</p>					

Präzisions-Innenausdreher, 7-tlg. Internal Pullers, 7-pcs.



Art.-Nr. / No.	mm	g	VE	EUR	731/201
0731 02 01	10-75	6800	1	538,00	
<p>Inhalt / content:</p> <ul style="list-style-type: none"> - Innenausdreher / Internal Pullers 10-13, 14-19, 20-25, 25-30, 30-37, 38-45, 40-75mm - 2 Gegenstützen / 2 Counter Stays 					
<p>9-tlg.-Satz, zum Ausziehen von Kugellagern, Kugellager-Außenringen und Büchsen, mit geschlitztem, vierteiligem Schaft, gleichmäßig radial spreizbare Segmente für präzises, sicheres und schonendes Ausziehen zusammen mit Gegenstütz-Vorrichtung und Schlagauszieher, in schwarzem Metallkasten</p> <p>9-pcs. set, for extracting ball bearings, outer rings and bushings, to be used with counter stays and slide hammer, in black metal case</p>					

Präzisions-Innenausdreher, 9-tlg. Internal Pullers, 9-pcs.



Art.-Nr. / No.		g	VE	EUR	731/300
0731 03 00	11-tlg. / pcs.	2200	1	295,00	
<p>11-tlg.-Universal-Satz, zum Abziehen der vorderen und hinteren Scheibenwischer, für ca. 450 verschiedene Wischer, 300 Fahrzeugtypen und 30 Automarken, für Pkw und Nfz, mit Anwendungstabelle, in schwarzem Kunststoffkoffer</p> <p>11-pcs. universal set, for pulling off windscreen wiper arms and rear window wiper arms, for more than 450 different wiper arms, 300 vehicles and 30 car brands, table of use is inserted, in black plastic case</p>					

Scheibenwischerarm-Abzieher-Satz Windscreen Wiper Arm Pulling Set



Art.-Nr. / No.	A mm	B mm	g	VE	EUR	731/400
0731 04 00	195	88	2750	1	168,00	
<p>15-tlg.-Universal-Satz, für Pkw, zum Abziehen von Riemenscheiben, für Scheiben mit oder ohne Gewindelöcher, zusätzlich mit Zahnhaken (greifen in die Rillen, wenn ein Hintergreifen mit Standardhaken nicht möglich ist), in schwarzem Kunststoffkoffer</p> <p>15-pcs. universal set, for vehicles, for V-Belt pulleys with or without threadhole, with groove hooks to fit into the grooves of V-Belt pulley, in black plastic case</p>						
<p>A = Spannweite / spread B = Spanntiefe / reach</p>						

Riemenscheiben-Abzieher-Satz V-Belt Pulley Puller Set



Schneidwerkzeuge / Cutting Tools

Stehbolzen-Ausdreher Stud Extractors



730

Zum Ein- und Ausdrehen von Stehbolzen mit Rechts- und Linksgewinde, Chrom-Vanadium-Stahl 31 CrV 3 (W.-Nr. 1.2208)

For turning in and out studs with right- and left-handed thread, Chrome-Vanadium-Steel 1.2208

Art.-Nr. / No.	mm	mm	g	VE	EUR
0730 00 01	5 – 15	19	360	1	43,00
0730 00 02	10 – 19	19	400	1	49,00
0730 00 03	18 – 28	19	450	1	58,00

Schraubenausdreher-Sätze Screw Extractor Sets



771

Zum Ausdrehen von abgerissenen Schrauben und Bolzen mit Rechtsgewinde, geschliffen, Chrom-Vanadium-Stahl 58 CrV 4 (W.-Nr. 1.8161)

For turning out worn screws and bolts with right-handed thread, polished, Chrome-Vanadium-Steel 1.8161

Art.-Nr. / No.		g	VE	EUR
0771 00 01	5-tlg. / pcs. M3-18, 1/8-3/4"	150	1	9,95
0771 00 02	6-tlg. / pcs. M3-24, 1/8-1"	160	1	15,95
0771 00 03	8-tlg. / pcs. M3-45, 1/8-1.3/4"	800	1	36,95

Werkzeughalter Tap Wrenches



772

Für Gewindebohrer, mit Quergriff und umschaltbarer Knarre, für Links- und Rechtsgang, verchromt

For tap, with sliding T-handle, with ratchet for left and right hand use, chrome plated

Art.-Nr. / No.		g	VE	EUR
0772 00 01	80mm M3-M10; 2,4-5,5	155	1	16,95
0772 00 02	100mm M5-M12; 4,5-7	330	1	22,95

Impact-Schraubenausdreher-Satz Twist Socket Set

□ 3/8"



773

Zum Lösen extrem beschädigter Muttern und Schrauben durch spezielles Spiral-Nuten-Profil, mit 3/8"-Antrieb, schlagschraubergeeignet, mit Ausschlagbolzen zum Ausschlagen der gelösten Schrauben und Muttern aus dem Einsatz, Spezialstahl, brüniert

Quickly and easily remove damaged or rounded nuts and bolts, simply place socket on fastener and turn with impact gun, no hammering required to install socket over fastener, applications include oil pan drain plugs, exhaust manifold nuts, studs, pipe nipples and corroded marine fasteners, special steel, black phosphated

Art.-Nr. / No.		g	VE	EUR
0773 00 01	10-tlg. / pcs. 10, 11, 12, 13, 14 15, 16, 17, 19mm + Bolzen / Pin	700	1	85,00



Art.-Nr. / No.	M	g	VE	EUR	820
0820 00 01	4 - 17mm - M10	280	1	58,00	Für fest sitzende oder überdrehte Muttern, mechanisch, für Muttern bis Güteklasse 6, besonders schwere Ausführung, Vergütungsstahl
0820 00 02	8 - 24mm - M16	440	1	65,00	
0820 00 03	19 - 36mm - M24	610	1	98,00	
For splitting and removing unbreakable nuts, quality range up to grade 6, extra solid pattern, mechanic, special steel					
0820 00 11	4 - 17mm - M10	35	1	22,00	Ersatzmeißel / spare chisels
0820 00 12	8 - 24mm - M16	35	1	22,00	
0820 00 13	19 - 36mm - M24	40	1	39,00	

Muttersprenger, mechanisch

Mechanical Nut Splitters



Art.-Nr. / No.	g	VE	EUR	822	
0822 00 01	7 - 22mm M 4 - M 14	795	1	119,00	Für fest sitzende oder überdrehte Muttern, hydraulisch, für Muttern bis Güteklasse 10, Meißel vergütet und ab der Schneide zusätzlich induktiv gehärtet, Kanäle rolliert, besonders schwere Ausführung, mit Beschreibung, Vergütungsstahl C-45 (W.-Nr. 1.0503)
0822 00 02	22 - 36mm M 14 - M 24	2500	1	198,00	
For splitting and removing unbreakable nuts, hydraulic, quality range up to grade 10, extra solid pattern, with manual, special steel 1.0503					
0822 00 11	7-22mm	35	1	31,00	Ersatzmeißel / spare chisels
0822 00 12	22-36mm	40	1	35,00	

Muttersprenger, hydraulisch

Hydraulic Nut Splitters



Art.-Nr. / No.	g	VE	EUR	774	
0774 00 01	MM (ISO) Gewindesteigung / thread pitch: 0,8; 1,0; 1,25; 1,5; 1,75; 2,0; 2,5; 3,0mm	120	1	42,95	Zur Instandsetzung beschädigter Innen- und Außen-gewinde, Länge 230mm
0774 00 02	SAE (UNF/UNC) Gänge auf 1 Zoll / threads per 1 inch: 24; 20; 18; 16; 14; 13; 12; 11	120	1	42,95	
0774 00 03	Whit (BSW/BSF) Gänge auf 1 Zoll / threads per 1 inch: 24; 20; 18; 16; 14; 12; 11; 10	120	1	42,95	
For restoring damaged inside and outside threads, length 230mm					

Gewindefeilen

Thread Restorers



Art.-Nr. / No.	g	VE	EUR	774/1	
0774 01 01	M 3 x 0,5	15	5	3,20	Zur Gewindereparatur beschädigter oder abgenutzter Gewinde, zur Gewindepanzerung von Werkstoffen mit geringer Scherfestigkeit, z.B. Magnesium- und Aluminium-Legierungen, im Maschinenbau, in der Kfz-, Elektro- und Medizintechnik usw. Hochwertiger Chrom-Nickel-Stahl
0774 01 02	M 4 x 0,7	17	5	3,20	
0774 01 03	M 5 x 0,8	20	5	4,10	
0774 01 04	M 6 x 1,0	25	5	4,10	
0774 01 05	M 8 x 1,25	30	5	5,60	
0774 01 06	M 10 x 1,5	40	5	6,70	
For drilling, tapping and deburring in one operation using battery-powered screwdriver drills and electric hand drills. Suitable for universal use in materials of medium mechanical strength, non ferrous metals and thermoplastics (up to 600 Nm ² tensile strength). Take care that the tool and the axis of the hole are exactly aligned and use a suitable cutting oil.					

Einschnittgewindebohrer-Bits

Threading-Bits



Schneidwerkzeuge / Cutting Tools

Gewindereparatursätze Thread Repair Sets



774/2

Zur Gewindereparatur beschädigter oder abgenutzter Gewinde, komplett mit Spiralbohrer, Handeinbau-Werkzeug, Gewindebohrer, Zapfenbrecher und Gewindeeinsätzen, aus hochwertigem Chrom-Nickel-Stahl

For the repair of damaged or worn-out threads, reuse of rejects, high-quality chrome-nickel stainless steel, provides good female threads resisting the influences of weathering and corrosion, complete sets with twist drill, installation tool, screw tap, pin breaking tool and threaded inserts

Art.-Nr. / No.		g	VE	EUR
0774 02 01	M 3 x 0,5	15	5	21,95
0774 02 02	M 4 x 0,7	17	5	21,95
0774 02 03	M 5 x 0,8	20	5	22,50
0774 02 04	M 6 x 1,0	25	5	23,95
0774 02 05	M 8 x 1,25	30	5	31,30
0774 02 06	M 10 x 1,5	40	5	32,95

Zündkerzen-Gewindereparatursatz Thread Repair Set for spark plugs



774/3

Zur Gewindereparatur beschädigter oder abgenutzter Zündkerzengewinde, komplett mit Spiralbohrer, Handeinbau-Werkzeug, Gewindebohrer, Zapfenbrecher und Gewindeeinsätzen, aus hochwertigem Chrom-Nickel-Stahl

For the repair of damaged or worn-out spark plug threads, reuse of rejects, high-quality chrome-nickel stainless steel, provides good female threads resisting the influences of weathering and corrosion, complete sets with twist drill, installation tool, screw tap, pin breaking tool and threaded inserts

Art.-Nr. / No.		g	VE	EUR
0774 03 01	M 14 x 1,25	320	1	49,95

Gewinde-Reparatur-Sortiment Thread Repair Assortment



774/4

Zur Gewindereparatur beschädigter oder abgenutzter Zündkerzengewinde, komplett mit Spiralbohrer, Handeinbau-Werkzeug, Gewindebohrer, Zapfenbrecher und Gewindeeinsätzen, aus hochwertigem Chrom-Nickel-Stahl

For the repair of damaged or worn-out spark plug threads, reuse of rejects, high-quality chrome-nickel stainless steel, provides good female threads resisting the influences of weathering and corrosion, complete set with twist drill, installation tool, screw tap, pin breaking tool and threaded inserts

Art.-Nr. / No.		g	VE	EUR
0774 04 01	130-tlg. / pcs. M 5 - M 12	640	1	152,00

Inhalt / content:
Bohrer / drills: M 5 - M 12
5,2 - 6,3 - 8,3 - 10,4 - 12,4mm
No. 8 - 9 - 11 - 13 - 15

Gewindeeinsätze / threaded inserts:
No. 8 - 9 - 11 - 13: 25x
No. 15: 10x

Multi-Gewindereparatur-Werkzeug Universal Rethreading Tools



Externes Gewinde /
External Thread

Internes Gewinde /
Internal Thread

774/5

Universal-Werkzeug, zur schnellen und dauerhaften Gewindereparatur beschädigter oder abgenutzter Gewinde, greift hinter die beschädigten Bereiche und zieht automatisch das Gewinde nach, aus hochwertigem Spezial-Stahl

Automatical adjusts any thread diameter and pitch, can be used on left hand or right hand threads, both inch and metric sizes, no prior measurement of the thread; external and internal thread restorers have the capability to enter BELOW the damaged area and work outwards to complete the repair; blades made of hardened high speed steel

Art.-Nr. / No.	mm	"	g	VE	EUR
Extern / External					
0774 0501	4-18	5/32-11/16"	225	1	72,00
0774 0502	17-38	11/16-1.1/2"	550	1	105,00
Intern / Internal					
0774 0511	8-11	5/16-7/16"	160	1	79,80
0774 0512	12-16	1/2-5/8"	170	1	79,80
0774 0513	16-20	11/16-13/16"	250	1	87,10
0774 0514	22-32	7/8-1.1/4"	450	1	115,00



Art.-Nr. / No.	mm	"	g VE		EUR	
			g	VE		
0775 00 01	150	6	100	5	5,50	Flachstumpf / hand DIN 7261 A, ISO R 234
0775 00 10	200	8	185	5	6,30	
0776 00 01	250	10	350	5	8,20	
0775 00 02	150	6	100	5	5,90	Dreikant / threesquare DIN 7261 C, ISO R 234
0775 00 11	200	8	195	5	9,20	
0776 00 02	250	10	340	5	12,60	
0775 00 03	150	6	70	5	5,70	Rund / round DIN 7261 F, ISO R 234
0775 00 12	200	8	105	5	7,30	
0776 00 03	250	10	190	5	9,20	
0775 00 04	150	6	60	5	6,30	Vierkant / square DIN 7261 D, ISO R 234
0775 00 13	200	8	125	5	8,20	
0776 00 04	250	10	240	5	9,90	
0775 00 05	150	6	80	5	8,95	Halbrund / halfround DIN 7261 E, ISO R 234
0775 00 14	200	8	165	5	10,90	
0776 00 05	250	10	300	5	14,90	
0778 00 02	200	8	750	1	29,95	Feilen-Satz, 5-tlg., DIN 7261 A - F, Hieb 2, in Plastiktasche Set of Files, 5-pcs., DIN 7261 A - F, second cut, in plastic wallet - Flachstumpf DIN 7261 A, ISO R 234 / hand - Dreikant, DIN 7261 C / ISO R 234 / threesquare - Rund, DIN 7261 F / ISO R 234 / round - Vierkant, DIN 7261 D / ISO R 234 / square - Halbrund, DIN 7261 E / ISO R 234 / halfround

775-778

Werkstattfeilen Engineers' Files



Art.-Nr. / No.	mm	g VE		EUR	
		g	VE		
0779 00 01	150	110	1	13,55	Schlüsselfeilen-Satz, 6-tlg., DIN 7283 A-F, in Plastiktasche, Hieb 2 Set of Warding Files, 6-pcs., DIN 7283 A-F, in plastic wallet, second cut - Flachstumpf, DIN 7261 A, ISO R 234 / hand - Dreikant, DIN 7261 C / ISO R 234 / threesquare - Rund, DIN 7261 F / ISO R 234 / round - Vierkant, DIN 7261 D / ISO R 234 / square - Halbrund, DIN 7261 E / ISO R 234 / halfround - Flachspitz, DIN 7283 B, ISO R 234 / flat pointed

779

Schlüsselfeilen, 6-tlg. Set of Warding Files, 6-pcs.



Art.-Nr. / No.	mm	g VE		EUR	
		g	VE		
0780 00 01	150x8x0,8	70	5	5,80	Für Zündkerzen, aus Spezialstahl For spark plugs, special steel

780

Kontaktfeilen-Satz, 6-tlg. Set of Contact Files, 6-pcs.



Schneidwerkzeuge / Cutting Tools

Ketten-Rohrabschneider Chain Pipe Cutter

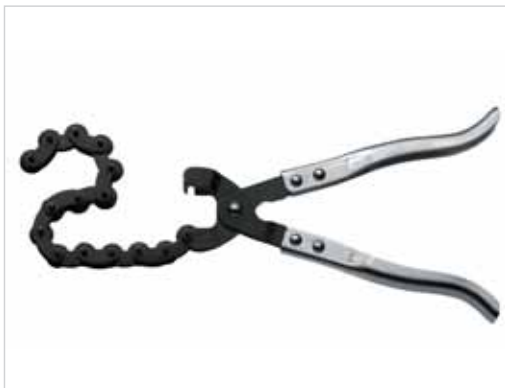

808

Zum Trennen von (Auspuff-)Rohren zwischen 25 - 75mm Ø und bis 2,5mm Wandstärke, auch für Rohre aus rostfreiem Stahl, Kupfer und PVC, Schneidradchen aus hochfestem Spezialstahl, vernickelt

For cutting tubes up to 75 mm Ø and up to 2,5 mm thickness, as well as for tubes made of stainless steel, copper and PVC, especially for dismantling exhaust systems

Ersatzkette / Chain

Art.-Nr. / No.	mm	g	VE	EUR
----------------	----	---	----	-----

0808 00 01	265	510	1	75,00
------------	-----	-----	---	-------

0808 00 02		185	1	65,00
------------	--	-----	---	-------

Rohrabschneider Metal Pipe Cutter



810

Für Rohre aus Kupfer, Messing, Leichtmetall, dünnwandigem Stahl, PVC und Hartkunststoff, mit Entgratungsmesser im Griff, lackiert

For copper, brass, aluminium, thin walled steel pipes, PVC and hard plastic pipes, with adjusting knob incorporating a reamer, with trimming knife in the handle, lacquered

Schneidradchen / Cutting wheels
Bolzen / Bolts

Art.-Nr. / No.	mm	g	VE	EUR
----------------	----	---	----	-----

0810 00 01	1/8 - 1.3/8" 3 - 35mm	400	5	39,00
------------	--------------------------	-----	---	-------

0810 00 11		3	5	6,30
0810 00 12		6	5	3,00

Rohrabschneider Metal Pipe Cutter



813

Für Rohre aus Kupfer, Messing, Leichtmetall, dünnwandigem Stahl, PVC und Hartkunststoff, 4-Rollenführung, autom. Vorschub, mit Entgratungsmesser im Griff, lackiert

For copper, brass, aluminium, thin walled steel pipes, PVC and hard plastic pipes, 4-rollers guide, automatic feed, with adjusting knob incorporating a reamer, with trimming knife in the handle, lacquered

Schneidradchen / Cutting wheels
Bolzen / Bolts

Art.-Nr. / No.	mm	g	VE	EUR
----------------	----	---	----	-----

0813 00 01	1/8 - 1.3/8" 3 - 35mm	320	1	58,00
------------	--------------------------	-----	---	-------

0810 00 11		3	5	6,30
------------	--	---	---	------

Kleinstrohrabschneider Mini Pipe Cutter



814

Für Rohre aus Kupfer, Messing, Leichtmetall, dünnwandigem Stahl, PVC und Hartkunststoff, 4-Rollenführung, autom. Vorschub, mit Entgratungsmesser im Griff, lackiert



For copper, brass, aluminium, thin walled steel pipes, PVC and hard plastic pipes, 4-rollers guide, automatic feed, with adjusting knob incorporating a reamer, with trimming knife in the handle, lacquered

Schneidradchen / Cutting wheels

Art.-Nr. / No.	mm	g	VE	EUR
----------------	----	---	----	-----

0814 00 01	1/8 - 5/8" 3 - 16mm	100	1	23,00
------------	------------------------	-----	---	-------

0810 00 11		3	5	6,30
------------	--	---	---	------

Art.-Nr. / No.	mm / AF	 g	 VE	EUR	835
0835 00 01	4; 4,75; 6; 8; 10; 12; 15mm	1250	1	177,00	Zum Bördeln von Kupfer-, Messing- und Leichtmetallrohren (nicht für Bremsleitungen!), mit auswechselbaren Spannbacken, Öffnungswinkel 90-45° Abwinklung vom Rohr For flaring on copper, metal and aluminium tubes (not for brake air conduits), with interchangeable jaws, opening angle 90 – 45°
0835 00 02	3/16; 1/4; 5/16; 3/8; 7/16; 1/2; 5/8" AF	1250	1	177,00	
0835 00 03	4 - 15mm	635	1	118,00	Ersatz-Spannbacken / Spare Clamping Jaws
0835 00 04	3/16 - 5/8"	635	1	118,00	
0835 00 05			1	6,00	Zwischenstück für 180° Bördel / Cone for 180° flaring

Bördelgeräte Flaring Tools



Art.-Nr. / No.	mm / AF	 g	 VE	EUR	835/100
0835 01 00	4-15	2600	1	125,00	3-tlg. Satz mit Bördelgerät 835, Spannbacken und Rohrabschneider 810, in Metallkasten 3-pcs. set with flaring tool 835, clamping jaws and metal pipe cutter 810, in metal case
0835 01 01	3/16-5/8" AF	2600	1	125,00	



Schneid- und Bördelsatz Tubing Cutter and Flaring Tool Set



Art.-Nr. / No.	 mm	 mm	 g	 VE	EUR	825/826
0825 00 01	90	200	85	10	6,50	Klappmesser, mit gerader, gehärteter Klinge und Holzgriff With straight, hardened blade and wooden handle
0826 00 01	180	65	5	5	9,50	Mit gerader, gehärteter Klinge, Klinge aus rostfreiem Stahl, mit Schutzkappe, Griff VDE isoliert, nach ICE 900, VDE- und GS-geprüft With straight, hardened blade, blade made from stainless steel, VDE insulated handle, acc. to IEC 900, VDE and GS tested

Kabelmesser Cable Knife



Art.-Nr. / No.	 mm	 g	 VE	EUR	826/2
0826 00 02	180	200	5	7,90	Aus Druckguß mit 5er Magazin, selbstnachladend, mit Softgriff Aluminium pressure casting, with 5 blades, adjustable and reversible blade, with softgrip
0826 00 03	5-tlg. / pcs.	18	1	1,50	5 Ersatz-Abbrechklingen, mit 8 Schneiden, chromlegierter Schwedenstahl, 18mm 5 Blades with 8 precuts, made of superior steel, 18mm

Sicherheitsmesser Safety Cutter



Messwerkzeuge / Measuring Tools

Fühlerlehren Feeler Gauges



760

Mit Schutzgriff, einklappbar, Blattlänge 100 mm, konische Blattform, poliert, aus Federbandstahl

Blades fold into metal case, blade length 100 mm, 4" tapered blades, polished, spring steel strip material

Art.-Nr. / No.		mm	g	VE	EUR
0760 00 02	13	0,05–1,00	70	10	3,90
0760 00 03	20	0,05–1,00	100	10	5,50
0760 00 05	13	2–35/100	50	10	3,90
0760 00 06	20	2–40/100	80	10	5,50

Gewindeschablonen Thread Gauges



764

Für metrische und Whitworth-Gewinde; zum Prüfen der Steigung bei Innen- und Außengewinden; flacher Haltebügel mit Klemmschrauben zum Arretieren der Blättchen

For metric and Whitworth threads, for checking inside and outside radius

Art.-Nr. / No.		mm	g	VE	EUR
0764 00 01	24	0,25–6,00	40	10	4,10
0764 00 03	5	20,25–6,00 + 4–62 W	75	10	4,10

Bandmaße Measuring Tape



798

Automatischer Bandeinzug mit Rücklaufsperre, Maßband gewölbt, mit Doppelskala und abrutschsicherem Gleitendhaken für genaue Innen- und Außenmessung, besonders stabil

Automatic tape rewriter with return stop, measuring tape vaulted, with double scale and hook for precise inside and outside measurements, very solid

Art.-Nr. / No.		m	g	VE	EUR
0798 00 02	3		70	10	6,50
0798 00 05	5		85	10	11,90

Stahlmaßstäbe, biegsam Rules, flexible

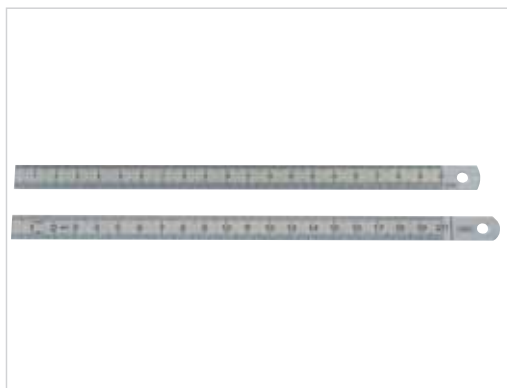

798/10

Gehärtet, mattverchromte blendfreie Teilung in mm und 1/2 mm, beidseitige Doppelskala, rostfreier Federbandstahl, Toleranz EG Klasse II

Hardened steel, satin chrome finish, etched reading mm and 1/2 mm, double scale, spring hardened steel

Art.-Nr. / No.		mm	g	VE	EUR
0798 10 20		200x15x0,5	6	10	2,30
0798 10 30		300x15x0,5	20	10	2,50

Art.-Nr. / No.	mm	g	VE	EUR	798/20
0798 20 30	300x30x1,0	25	5	7,60	<p>Gehärtet, mattverchromte blendfreie Teilung in mm und 1/2 mm, beidseitige Doppelskala, rostfreier Federbandstahl, Toleranz EG Klasse II</p> <p>Hardened steel, satin chrome finish, etched reading mm and 1/2 mm, double scale, spring hardened steel</p>

Stahlmaßstäbe, starr

Rules, non flexible

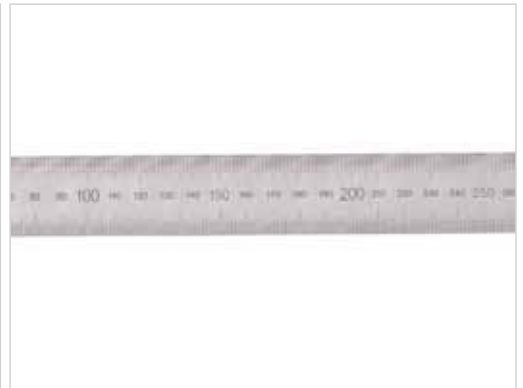

Art.-Nr. / No.	mm	g	VE	EUR	798/30
0798 30 20	200x22x6	105	1	39,90	<p>Zum Prüfen der Ebenheit von Flächen, mit zwei Haarmesskanten, Messflächen geläpft, ganz gehärtet mit Griffisolation zum Schutz vor Handwärme, aus rostfreiem Material, DIN 874, Genauigkeit 00</p> <p>For checking the evenness of surfaces, with two measuring edges, measuring surfaces lapped, hardened, with heat-insulated handle, stainless steel, DIN 874</p>

Präzisions-Haarlineal

Precision Straight-Edge Rule



Art.-Nr. / No.	mm	g	VE	EUR	798/31
0798 31 10	100x70 (20x5)	150	1	16,90	<p>Mit Anschlag, auf 90° gerichtet, Spezialstahl, verzinkt</p> <p>For locksmith work, blade with stop, 90° angled, special steel, zinc plated</p>
0798 31 20	200x130 (28x6)	650	1	29,50	
0798 31 30	300x175 (32x7)	1000	1	49,60	

Werkstattwinkel

Workshop Squares



Art.-Nr. / No.	mm	g	VE	EUR	798/40
0798 90 40	400	240	1	16,90	<p>Mit je einer Horizontal- und Vertikal-Libelle, Messgenauigkeit: 0,5mm per 1m = 0,028 °, schraublos befestigte Libellen; unverstellbar, stoßfest und wetterbeständig, Garantie: 5 Jahre auf Libellen</p> <p>With one horizontal and one vertical vial; unbreakable, solid acrylic block vials, accuracy of 0,5mm/metre = 0,028 ° in standard position; unadjustable - weather constant, guarantee: 5 years on vials</p>

Wasserwaage

Spirit Level



Messwerkzeuge / Measuring Tools

Präzisions-Taschenmeßschieber Precision Vernier Caliper

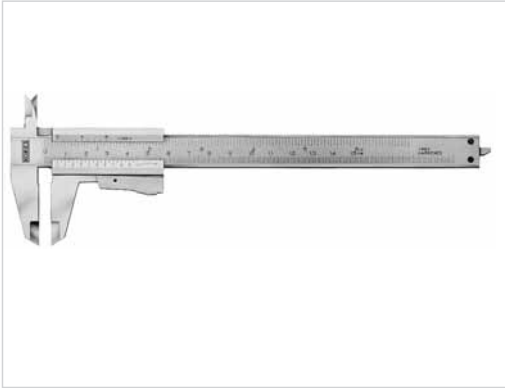

798/50

Für Innen-, Außen-, und Tiefenmessung, Ablesung 0,05mm - 0,008", nach DIN 862, matt verchromt, mit erhöhten Führungsbahnen, Nonius auf 39mm erweitert, Schnabellänge 40mm, mit Momentfeststellung, rostfrei

For inside, outside and depth measuring, display 0.05mm - 0.008", accord. to DIN 862, matt chrome finish, with raised slideways, vernier scale extended up to 39mm, jaws 40mm, with thumb lock, stainless steel

Art.-Nr. / No.	mm	g	VE	EUR
----------------	----	---	----	-----

0798 50 15	150	110	1	34,20
------------	-----	-----	---	-------

Digitaler Taschenmeßschieber Electronic Caliper



798/50

Für Innen-, Außen-, Stufen- und Tiefenmessung (4 Wege), Ablesung 0,01mm - 0,0005"; Genauigkeit 0,01mm - 0,0005" nach DIN 862; rostfrei; gehärtet; umschaltbar von mm auf Zoll; mit Datenausgang (Schnittstelle RS232C); in stabiler Hartbox

For inside, outside, step and depth measuring (4 ways); display and accuracy 0.01mm - 0.0005", stainless steel, hardened, matt chrome finish, reversible from mm to inch, with interface RS232C for data processing, accuracy according to DIN 862, in plastic case

Art.-Nr. / No.	mm	g	VE	EUR
----------------	----	---	----	-----

0798 50 20	150	410	1	43,00
------------	-----	-----	---	-------



Hartmetall-Reißnadel Hard Metal Marking Tool



799

Standard-Ausführung / Standard-Type

Zum Anreißen extra harter Werkstoffe, Reißnadel versenkbar, auswechselbar, mit Spannutter, Schaft mit Ansteckclip und Riffelung im Griffbereich

Retractable for protection of the point and prevention of injuries, replaceable, secure hold of the point via chuck, shaft with clip and knurled grip area

Art.-Nr. / No.	mm	g	VE	EUR
----------------	----	---	----	-----

0799 00 01	140	15	10	9,50
------------	-----	----	----	------

0799 00 02	140	14	10	23,50
------------	-----	----	----	-------

Ersatzspitze / Spare Tip 0799 00 03		15	10	11,50
--	--	----	----	-------

Reißnadel Scriber



799/10

Mit einer geraden und einer abgewinkelten Stahlspitze, Spitze eingeschraubt, Griff brüniert und kordiert

With one straight and one angled screwed-in steel point, handle gun metal finish and knurled

Art.-Nr. / No.	mm	g	VE	EUR
----------------	----	---	----	-----

0799 10 10	250	52	10	2,95
------------	-----	----	----	------

Ersatzspitze gerade / Spare Tip straight 0799 10 20				0,75
--	--	--	--	------

Ersatzspitze gebogen / Spare Tip bent 0799 10 30				0,75
---	--	--	--	------



Drehmomentwerkzeuge.

Einstellbare Drehmomentschlüssel
 Drehmomentschlüssel mit Festeinstellung
 Drehmomentschlüssel für Einsteckwerkzeuge
 Drehmoment-Tester

Torque Wrenches and Accessories.

Adjustable Torque Wrenches
 Preset Torque Wrenches
 Torque Wrenches for insert tools
 Electronic Tester

Art.-Nr. / No.	"	Nm	m.kgs.	mm	g	VE	EUR
6174 00 01	3/8"	10-60	1-6	370	600	1	55,00
6174 00 02	1/2"	30-130	3-13	470	800	1	65,00
6174 00 03	1/2"	55-300	5,5-30	630	1000	1	95,00

6174

Drehmomentschlüssel EcoLine Torque Wrenches EcoLine

- Einstiegsklasse
- für Links- und Rechtsanzug
- mit Umschaltknarre
- Skala für Nm und ft.lb.,
- mit akustischem Signal

- EcoLine
- for left and right hand use
 - with reversible ratchet
 - scale for Nm and ft.lb.
 - with acoustic indicator



Art.-Nr. / No.	"	Nm	ft.lb.	mm	g	VE	EUR
6175 00 11	1/2"	5-60	4-36	365	900	1	175,00
6175 00 12	1/2"	20-100	17-72	460	1100	1	179,00
6175 00 13	1/2"	40-220	43-160	530	1250	1	185,00

6175

Drehmomentschlüssel Torque Wrenches

- für Links- und Rechtsanzug
- mit Umschaltknarre inkl. Vierkantaufnahme
- Einstellhilfe am Griffende
- Skala für Nm und ft.lb.
- mit akustischem Signal
- Auslösegenauigkeit = $\pm 4\%$ vom eingestellten Skalenwert gemäß DIN EN ISO 6789:2003 (D)
- mit Seriennummer und Einzelprüfzeugnis

- for left and right hand use
- with reversible ratchet with inner square
- scale for Nm and ft.lb.
- with acoustic indicator
- releasing precision = $\pm 4\%$ of the preset scale value according to DIN EN ISO 6789:2003 (D)
- with serial number and calibration certificate

$\pm 4\%$



Transparenter Griff - zeigt den Meßwert an
 Transparent handle - indicates the right torque



Drehmoment-Werkzeuge / Torque Wrenches

Drehmomentschlüssel, extra lang Torque Wrenches, long type



± 4%

6174/10

- für Links- und Rechtsanzug
- mit Durchsteckvierkant
- Einstellhilfe am Griffende
- Skala für Nm und ft.lb.
- mit akustischem Signal
- Auslösegenauigkeit = ± 4% vom eingestellten Skalenwert gemäß DIN EN ISO 6789:2003 (D)
- mit Seriennummer und Einzelprüfzeugnis

- for left and right hand use
- with Push Through Square Drive
- scale for Nm and ft.lb.
- with acoustic indicator
- releasing precision = ± 4% of the preset scale value according to DIN EN ISO 6789:2003 (D)
- with serial number and calibration certificate

Art.-Nr. / No.	"	Nm	ft.lb.	mm	g	VE	EUR
6174 00 10	3/8"	5-33	4-24	410	690	1	195,00
6174 00 20	1/2"	25-150	20-110	560	1700	1	215,00
6174 00 30	1/2"	50-250	40-180	610	2300	1	248,00
6174 00 40	1/2"	70-350	50-260	780	3000	1	278,00
6174 00 50	3/4"	140-800	120-580	935	6500	1	785,00



Drehmomentschlüssel, feinverzahnt Torque Wrenches, with 72T-Ratchet



± 3%

72T

6176

- für Links- und Rechtsanzug
- fein verzahnter Umschaltknarre (außer 61760040 = Durchsteckknarre)
- Skala für Nm und ft.lb.
- mit akustischem Signal
- Auslösegenauigkeit = ± 3% vom eingestellten Skalenwert gemäß DIN EN ISO 6789:2003 (D)
- mit Seriennummer und Einzelprüfzeugnis
- mit 2-Komponenten-Griff

- for left and right hand use
- with 72T-reversible ratchet
- scale for Nm and ft.lb.
- with acoustic indicator
- releasing precision = ± 3% of the preset scale value according to DIN EN ISO 6789:2003 (D)
- with serial number and calibration certificate
- with soft feel dual compound handle for excellent grip even in oily conditions
- handle material and lens resistant to all chemicals in common automotive, industrial and aviation use

Art.-Nr. / No.	"	Nm	ft.lb.	mm	g	VE	EUR
6176 00 01	1/4"	4-20	3-14,76	220	385	1	185,00
6176 00 10	3/8"	8-60	6-45	300	600	1	195,00
6176 00 20	3/8"	20-100	15-80	340	700	1	195,00
6176 00 30	1/2"	40-200	30-150	440	955	1	215,00
6176 00 40	1/2"	60-330	42-250	675	1440	1	230,00



6176 00 01

Neuer 2-Komponenten-Griff / New 2-compound handle



Art.-Nr. / No.	"	Nm	ft.lb.	mm	g	VE	EUR
6176 00 50	3/8"	8-60	5-45	220	400	1	155,00
6176 00 60	1/2"	10-100	8-80	330	700	1	155,00
6176 00 70	1/2"	20-200	15-150	425	1000	1	178,00
6176 00 80	1/2"	30-300	22-220	660	1240	1	218,00

6176/50

Drehmomentschlüssel, festeingest. Preset Torque Wrenches



- Für Serienmontagen mit festeingestelltem Drehmomentwert:
- für Rechtsanzug
- fein verzahnter Umschaltknarre
- Skala für Nm und ft.lb.
- mit akustischem Signal
- Auslösegenauigkeit = $\pm 3\%$ vom eingestellten Skalenwert gemäß DIN EN ISO 6789:2003 (D)
- mit Seriennummer und Einzelprüfzeugnis
- einstellbar mit MATADOR Drehmomenttester 6180

- No scale, wrench must be set against a torque testing device
- for left and right hand use
- with 72T-reversible ratchet
- scale for Nm and ft.lb.
- with acoustic indicator
- releasing precision = $\pm 3\%$ of the preset scale value according to DIN EN ISO 6789:2003 (D)
- with serial number and calibration certificate
- can be set with MATADOR torque tester 6180



$\pm 3\%$
72T

Art.-Nr. / No.	"	Nm	ft.lb.	mm	g	VE	EUR
6177 00 05	3/4"	140-800	120-600	1010	4400	1	698,00

6177

3/4"-Drehmomentschlüssel 3/4"-Torque Wrench



- Ideal für Nutzfahrzeuge
- für Links- und Rechtsanzug
- mit Durchsteckknarre
- Skala für Nm
- mit akustischem Signal
- Auslösegenauigkeit = $\pm 4\%$ vom eingestellten Skalenwert gemäß DIN EN ISO 6789:2003 (D)
- automatisches Selbstausslösen
- schnelle Einstellung durch Drehen des Griffes

- Perfect for trucks
- for left and right hand use
- with Push Through Square Drive
- scale for Nm
- with acoustic indicator
- releasing precision = $\pm 4\%$ of the preset scale value according to DIN EN ISO 6789:2003 (D)
- quick adjustment by turning the handle
- locking of the preset value at the end of the handle



$\pm 4\%$

Drehmoment-Werkzeuge / Torque Wrenches

Digitale Drehmomentschlüssel Digital Torque Wrenches



6178

- Professional Line
- für Links- und Rechtsanzug
 - fein verzahnter Umschaltknarre
 - Skala für Nm, ft.lb. und in.lb.
 - mit akustischem und LED-Signal
 - 2 Arbeitsmodi
 - Batteriebetrieb
 - serielle Schnittstelle für PC/Drucker
 - Auslösegenauigkeit = ± 2% vom eingestellten Skalenwert gemäß DIN EN ISO 6789:2003 (D)
 - mit Seriennummer und Einzelprüfzeugnis

- Professional Line
- for left and right hand use
 - with 72T-reversible ratchet
 - scale for Nm, ft.lb. and in.lb.
 - with acoustic and optical indicator (3 LED)
 - 2 different modes of operation
 - serial port for PC/Printer
 - releasing precision = ± 2% of the preset scale value according to DIN EN ISO 6789:2003 (D)
 - with serial number and calibration certificate

Art.-Nr. / No.	"	Nm	ft.lb.	mm	g	VE	EUR
6178 00 10	1/2"	20-200	15-150	460	1260	1	365,00
6178 00 20	1/2"	34-340	25-250	560	1550	1	375,00

Elektronik-Kit mit 4 Akkus, Verbindungskabel für serielle Schnittstelle, Steckernetzteil 220V / Electronic Kit with rechargeable batteries, cable for serial port, power supply

6178 00 21					500	1	195,00
------------	--	--	--	--	-----	---	--------

Mit drehbarem Kopf für bequemes Ablesen aus jedem Winkel
With rotating head for viewing the display from any angle



Digitale Drehmomentschlüssel Digital Torque Wrenches



6178/1

- Professional Line
- für Links- und Rechtsanzug
 - Torsionsstabmessung anstelle Biegestab: Messung im Kopf des Schlüssels unmittelbar am Verschraubungsbereich, dadurch extrem hohe Präzision
 - mit starrem Vierkant
 - Skala für Nm, ft.lb. und in.lb.
 - mit akustischem und optischem LED-Signal
 - akustischer Dauersignalton bei Erreichen des Toleranzbereichs
 - serielle Schnittstelle für PC/Drucker
 - 2 Arbeitsmodi
 - drehbares Display für bessere Ablesbarkeit
 - Auslösegenauigkeit = ± 1% vom eingestellten Skalenwert gemäß DIN EN ISO 6789:2003 (D)
 - mit Seriennummer und Einzelprüfzeugnis
 - kompakte Bauweise für Messungen in engsten Räumen

- Professional Line
- for left and right hand use
 - with torsion bar measurement, allows free choice of grip position, direct measurement in wrench head avoids inaccuracies
 - with fixed head square drive
 - scale for Nm, ft.lb. and in.lb.
 - with acoustic and optical indicator (3 LED)
 - additional acoustic signal upon reach of target value
 - serial port for PC/Printer
 - 2 different modes of operation
 - turnable display for perfect and easy reading
 - releasing precision = ± 2% of the preset scale value according to DIN EN ISO 6789:2003 (D)
 - with serial number and calibration certificate



Art.-Nr. / No.	"	Nm	ft.lb.	mm	g	VE	EUR
6178 00 07	1/4"	0,85-8,5	0,63-6,25	270	725	1	485,00
6178 00 05	3/8"	3-30	2,1-21	270	725	1	485,00
6178 00 06	1/2"	35-350	25-250	560	1400	1	495,00

Art.-Nr. / No.	"	Nm	ft.lb.	g	VE	EUR
6180 00 01	1/4"	1,1-11	0,8-8,30	2160	1	795,00
6180 00 02	3/8"	2,8-28	2,0-21	2160	1	795,00
6180 00 03	1/2"	34-340	25.250	2300	1	795,00

6180

Zum Testen von Drehmomentschlüsseln aller Art sowie zum Justieren von festeingestellten Drehmomentschlüsseln; extrem hohe Genauigkeit = ± 1% vom eingestellten Skalenwert; schnelle Einstellung von Zielwerten; schwenkbares LCD-Display; Anzeige in Nm, ft.lb oder in-lb; 3 Arbeitsmodi; detaillierte Erläuterung. Zum Montieren in der Werkstatt, auf der Werkbank etc. Weitere Größen auf Anfrage

For testing of nearly all types of torque wrenches and for adjusting pre-set torque wrenches; type reading in Nm, ft.lb. or in.lb., display can be swivelled into perfect position, accuracy ± 1% of preset value; acoustical and optical signal. Pls. ask for details



Elektr. Drehmomenttester, stationär
Torque Tester

±1%



Art.-Nr. / No.	"	g	VE	EUR
6181 00 01	1/2"	300	1	85,00
6181 00 02	3/4"	350	1	115,00

6181

Für winkelgesteuerten Schraubenanzug in einem Arbeitsgang; zur Betätigung mit Drehmomentschlüsseln mit 1/2"- bzw. 3/4"-Antrieb; für Rechts-/ Linksgang; mit flexiblem, magnetischem Halter für den Fixpunkt und den drehwinkelgesteuerten Schraubenanzug; Bereich 0-360°; Teilung / Skala 1°

For tightening screws as a function of the torsion angle; to be used between torque wrenches with 1/2" and 3/4" drive; with flexible magnetic holder for the fixing point; range 0-360°; graduation / scale 1°

Mechanische Winkelscheiben
Mechanical Angle Dials



Art.-Nr. / No.	"	"	kg	VE	EUR
6182 00 01	1/2"	3/4"	4,2	1	598,00

6182

Für schwergängige Verschraubungen; erspart den Einsatz von langen Hebeln usw.; wartungsarm; Genauigkeit ± 5%; mit Überlastungsschutz; Satz im schwarzen Kunststoffkoffer mit Ersatz-Vierkant

For tightening and loosening tight screwed connections; avoids the application of impact tools, lever arms etc.; low maintenance; high-accuracy ± 5%; with safety-protection against overloads; set in black plastic case with spare square drive

Technische Daten / details:
Übersetzungsverhältnis / torque ratio: 6:1
max. Krafteingang
max. input: 280 Nm / 206,6 Lbf.ft
max. Kraftausgang
max. output: 1680 Nm / 1239,8 Lbf.ft

Drehmoment-Vervielfältiger
Torque Multiplier



Drehmoment-Werkzeuge / Torque Wrenches

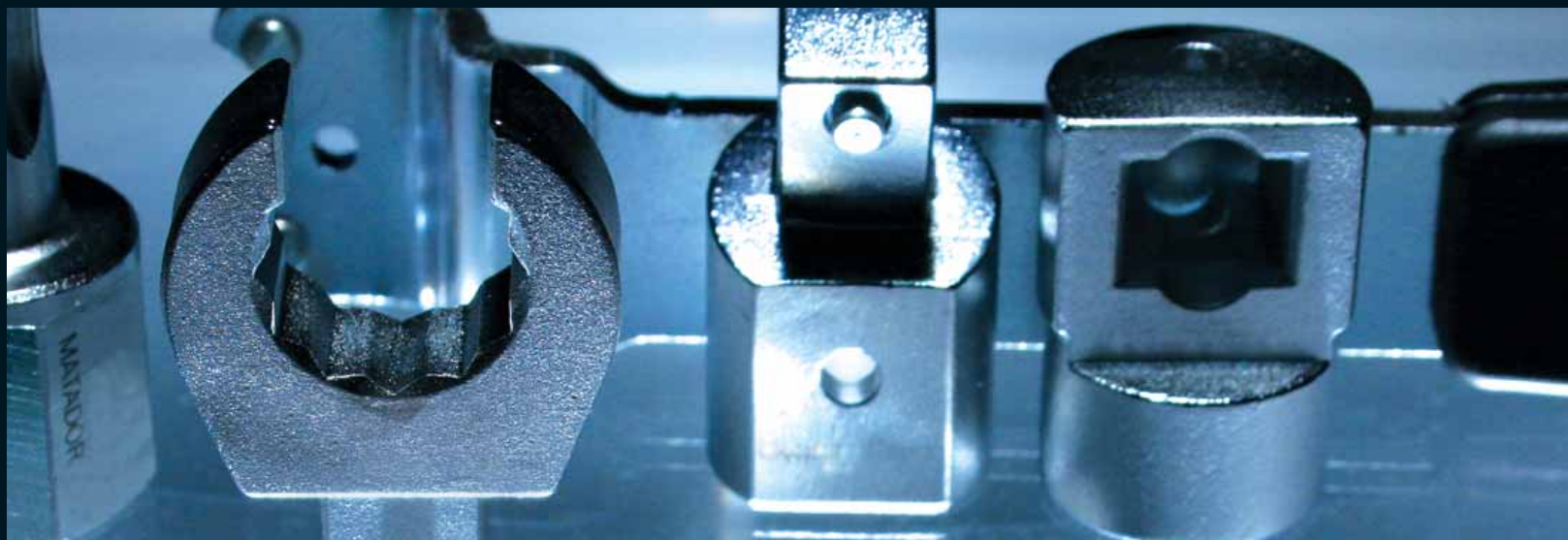

Einsteck-Gelenkgriff Swivel Handle for insert tools



6184

Art.-Nr. / No. mm " g VE EUR

6184 00 01 390 15 640 1 34,95

Aus Vollmaterial; mit Steckverbindung zur Aufnahme von Einsteckwerkzeugen in 9x12mm; ideal zum Lösen festsitzender Schrauben; ohne Drehmomentfunktion; Chrom-Vanadium-Stahl 31 CrV 3, voll galvanische Behandlung (vernickelt und verchromt), matt verchromt

Forged from solid steel; with plug-and-socket-connection in 9x12mm to accommodate insert tools; perfect for loosening tight screwed connections; Chrome-Vanadium-Steel 1.2208; matt chrome finish

Einsteck-Drehmomentschlüssel Torque Wrenches, for insert tools



± 3%

6185

Art.-Nr. / No. mm Nm ft.lb. mm g VE EUR

6185 00 01	9x12	8-60	6-45	300	600	1	185,00
6185 00 02	9x12	20-100	15-80	340	700	1	185,00
6185 00 03	14x18	40-200	30-150	440	955	1	215,00
6185 00 04	14x18	60-330	42-250	675	1440	1	265,00

- zur Aufnahme von Einsteckwerkzeugen in 9x12 u. 14x18
- für Links- und Rechtsanzug
- Skala für Nm und ft.lb.
- mit akustischem Signal
- Auslösegenauigkeit = ± 3% vom eingestellten Skalenwert gemäß DIN EN ISO 6789:2003 (D)
- mit Seriennummer und Einzelprüfzeugnis
- mit 2-Komponenten-Griff

- for insert tools
- for left and right hand use
- scale for Nm and ft.lb.
- with acoustic indicator
- releasing precision = ± 3% of the preset scale value according to DIN EN ISO 6789:2003 (D)
- with serial number and calibration certificate
- with soft feel dual compound handle for excellent grip even in oily conditions
- handle material and lens resistant to all chemicals in common automotive, industrial and aviation use

Art.-Nr. / No.	mm	Nm	ft.lb.	mm	g	VE	EUR
6185 00 50	9x12	8-60	5-45	220	400	1	168,00
6185 00 60	9x12	10-100	8-80	330	700	1	168,00
6185 00 70	9x12	20-200	15-150	425	1000	1	215,00
6185 00 80	14x18	30-300	22-220	660	1240	1	255,00

6185/50

Einsteck-Drehmomentschlüssel, fest Torque Wrenches, for insert tools, fix



Für Serienmontagen mit feinst-
gestelltem Drehmomentwert:

- für Rechtsanzug
- Skala für Nm und ft.lb.
- mit akustischem Signal
- Auslösegenauigkeit = $\pm 3\%$
vom eingestellten Skalenwert
gemäß DIN EN ISO
6789:2003 (D)
- mit Seriennummer und
Einzelprüfzeugnis
- einstellbar mit MATADOR
Drehmomenttester 6180

No scale, wrench must be set
against a torque testing device

- for left and right hand use
- scale for Nm and ft.lb.
- with acoustic indicator
- releasing precision = $\pm 3\%$
of the preset scale value
according to DIN EN ISO
6789:2003 (D)
- with serial number and
calibration certificate
- can be set with MATADOR
torque tester 6180



$\pm 3\%$

Art.-Nr. / No.	"	mm	g	VE	EUR
6186 00 01	1/4"	9x12	60	1	59,50
6186 00 02	3/8"	9x12	125	1	59,50
6186 00 03	1/2"	9x12	150	1	62,50
6186 00 04	1/2"	14x18	300	1	65,50

6186

Einsteck-Umschaltknarre Insert Reversible Ratchet

Für Drehmomentschlüssel mit Vierkantaufnahme
9x12mm oder 14x18mm

For torque wrenches with drive coupler 9x12mm or
14x18mm



Art.-Nr. / No.	"	mm	g	VE	EUR
6187 00 01	68	9x12	110	1	49,50

6187

Einsteck-Kardangeln Insert Universal Joint

Für Drehmomentschlüssel mit Vierkantaufnahme
9x12mm, zur Betätigung von Verschraubungen in
beengten Bereichen, 180° drehbar, matt verchromt.
Achtung: exakte Drehmomentwerte nur im geraden
Zustand

For torque wrenches with drive coupler 9x12mm, for
the operation of screwed connections in areas with
restricted access, 180° turnable, matt chrome finish.
Note: Precise torque value only in straight position



Einsteck-Maulschlüssel
Open End Insert Tools



6190

Für Drehmomentschlüssel mit Vierkantaufnahmen in 9x12mm oder 14x18mm; matt verchromt

For use with torque wrenches with drive coupler in 9x12mm and 14x18mm for insert tools; matt chrome finish

Art.-Nr. / No.	mm	mm	g	VE	EUR
6190 00 01	7	9x12	40	1	18,50
6190 00 02	8	9x12	40	1	18,50
6190 00 03	9	9x12	40	1	18,50
6190 00 04	10	9x12	40	1	19,00
6190 00 05	11	9x12	45	1	19,00
6190 00 06	12	9x12	45	1	19,50
6190 00 07	13	9x12	50	1	19,50
6190 00 08	14	9x12	50	1	19,50
6190 00 09	15	9x12	50	1	19,50
6190 00 10	16	9x12	58	1	20,00
6190 00 11	17	9x12	60	1	20,00
6190 00 12	18	9x12	70	1	20,00
6190 00 13	19	9x12	75	1	20,00
6190 00 21	13	14x18	130	1	20,50
6190 00 22	14	14x18	130	1	20,50
6190 00 23	15	14x18	130	1	20,50
6190 00 24	16	14x18	135	1	20,50
6190 00 25	17	14x18	135	1	21,00
6190 00 26	18	14x18	135	1	21,00
6190 00 27	19	14x18	140	1	21,00
6190 00 28	21	14x18	145	1	21,50
6190 00 29	22	14x18	145	1	21,00
6190 00 30	24	14x18	150	1	21,00
6190 00 32	27	14x18	160	1	21,00
6190 00 34	30	14x18	180	1	21,50
6190 00 35	32	14x18	180	1	21,50
Satz / Set					
6190 00 50		11-tlg. / pcs.	1400	1	375,00

Einsteck-Maulschlüssel-Satz
Set of Open End Insert Tools



Universal-Satz in Metallkasten, 11-tlg.
Universal set in metal case, 11- pcs.

Inhalt / contents:

- Einsteck-Drehmomentschlüssel (6185 00 01)
Torque wrench for insert tools
9x12mm; 8-60 Nm; 6-45 ft.lb.
- Einsteck-Umschaltknarre / Insert reversible ratchet
3/8" (6186 00 02)
- Einsteck-Kardangeln / Insert Universal Joint
- Einsteck-Maulschlüssel / Open End Insert Tools
8; 10; 11; 12; 13; 16; 17; 19mm

Einsteck-Ringratschenschlüssel
Box-End Ratchet Insert Tools





6191

Für Drehmomentschlüssel mit Vierkantaufnahme in 9x12mm, mit feinverzahnter Ringratsche, ideal für enge Zwischenräume, matt verchromt

For use with torque wrenches with drive coupler in 9x12mm for insert tools; ring type insert gear wrenches; 72T-ratchet; matt chrome finish

Art.-Nr. / No.	mm	mm	g	VE	EUR
6191 00 01	8	9x12	40	1	19,50
6191 00 02	10	9x12	40	1	19,50
6191 00 03	11	9x12	40	1	19,50
6191 00 04	12	9x12	40	1	19,50
6191 00 05	13	9x12	45	1	20,00
6191 00 06	16	9x12	45	1	22,50
6191 00 07	17	9x12	50	1	23,50
6191 00 08	19	9x12	50	1	24,50



Art.-Nr. / No.									
		g	VE	EUR					
Satz / Set									
6191 00 50	11-tlg. / pcs.	1500	1	385,00					

6191





Satz Einsteck-Ringratschenschl.
Set of Box-End Ratchet Insert Tools

Universal-Satz in Metallkasten, 11tlg.
Universal set in metal case, 11- pcs.

- Inhalt / contents:
- Einsteck-Drehmomentschlüssel (6185 00 01)
Torque wrench for insert tools
9x12mm; 8-60 Nm; 6-45 ft.lb.
 - Einsteck-Umschaltknarre / Insert reversible ratchet
3/8" (6186 00 02)
 - Einsteck-Kardangelenk / Insert universal joint
 - Einsteck-Ringratschenschlüssel / Box end ratchet
insert tools 8; 10; 11; 12; 13; 16; 17; 19mm



Drehmoment-Schraubendreher Torque Screwdrivers

Art.-Nr. / No.		Nm	Nm						
	"			mm	g	VE	EUR		
6195 00 01	1/4"	0,5-3	0,1	175	350	1	189,00		
6195 00 02	1/4"	1-6	0,1	200	410	1	199,00		

6195

Drehmoment-Schraubendreher
Torque Screwdrivers

- für kontrollierten Schraubenzug
 - für Links- und Rechtsanzug
 - Skala für Nm
 - Überlastungsschutz
 - Auslösegenauigkeit = ± 6% vom eingestellten Skalenwert gemäß DIN EN ISO 6789:2003 (D)
 - mit Seriennummer und Einzelprüfzeugnis
 - mit 1/4"-Aufnahme
-
- for controlled fixing
 - for left and right hand use
 - scale for Nm
 - slipper mechanism completely eliminates the possibility of overtightening
 - single direction release
 - step every 0.1Nm
 - releasing precision = ± 6% of the preset scale value according to DIN EN ISO 6789:2003 (D)
 - with serial number and calibration certificate
 - ergonomic handle
 - with 1/4"-drive



Verschiedenes / Miscellaneous

Bürsten Brushes

781/782

Art.-Nr. / No. \longleftrightarrow \varnothing \longleftarrow \rightleftarrows \rightleftarrows \rightleftarrows
mm g VE EUR



Zündkerzenbürste, zum Reinigen von Zündkerzen-
elektroden, mit Messingdraht

Sparking Plug Brush, to clean spark plugs, wood with
dense bronze wire fill

0781 00 01 150 20 10 2,50



Stahldrahtbürste, gebogene Form, Holz, Borsten aus
glatttem Stahldraht, mit 5 Reihen

Steel Wire Brush, with 5 rows, wood, tempered steel
wire fill

0782 00 01 290 x 40 150 5 2,30

Magnetheber Magnetic Pick Up Tools

784

Art.-Nr. / No. \varnothing \longleftrightarrow \varnothing \rightleftarrows \rightleftarrows \rightleftarrows
A mm mm B g g VE EUR



Flexibler Schaft, mit Neodym-Magnet für herausra-
gende Haftkraft

With Neodym-magnet, very high capacity, with
flexible shaft

0784 00 05 8 460 500 60 1 9,95
0784 00 01 12 460 1000 80 1 14,95
0784 00 02 15 520 1800 220 1 17,95
0784 00 03 19 520 3000 320 1 29,95

A = Kopfdurchmesser / Diameter head
B = Haftkraft garantiert / capacity guaranteed

Mini-Magnetheber, flexibel, Haftkraft 270g, spezieller
Neodym-Magnet, Durchmesser nur 4mm, für kleinste
Zwischenräume, ideal auch im Haushalt

0784 00 04 5 400 270 22 1 7,95

Mini-Magnetic Pick Up Tool, flexible, capacity 270g,
diameter of magnet only 4mm, perfect in household

Magnetheber mit Beleuchtung Magnetic Pick Up Tools with lamp

785

Art.-Nr. / No. \longleftrightarrow \rightleftarrows \rightleftarrows \rightleftarrows
mm VE EUR



Extra lang (900mm!), mit sehr heller LED-Leuchte,
Magnet mit herausragender Haftkraft bis zu 1500g,
mit flexiblem Schaft

0785 00 01 900 1 25,60

Extra long (900mm!), with LED light, high capacity
(up to 1500g), with flexible shaft

Ersatzbirne / Spare lamp
0785 00 91 10 5,00



Krallengreifer Gripping Tool with Claw

877

Art.-Nr. / No. \varnothing \longleftrightarrow \varnothing \rightleftarrows \rightleftarrows \rightleftarrows
mm mm g VE EUR



Mit biegsamem Schaft, zum Greifen von Kleinstteilen
an schwer zugänglichen Stellen, verchromt

0877 00 01 7 540 115 1 24,50

With flexible shaft, for gripping small pieces in other-
wise inaccessible places, chrome plated

Art.-Nr. / No.	↔		⚖		VE	EUR	786
	mm	g	g	g			
0786 00 01	440	800	5	16,90			
0786 00 03	300x13x0,6	18	50	1	2,60		

Blattstellung in 6 verschiedenen Positionen möglich, Blattspannung durch Drehen des Knopfes im Handgriff, mit Metall-Sägeblatt, HSS, einseitig, Hand- und Frontgriff aus Aluminium

Blade can be adjusted in 6 positions, easy adjustment of blade tension by turning bottom in handle, with blade, HSS, single edge, hand and front grip made of aluminium pressure casting

Metallsägeblatt Hexo SS, 24 Zähne per Zoll / Hacksaw blade, 24 teeth per inch

Metallsägebogen Hacksaw Frame



Art.-Nr. / No.	↔		⚖		VE	EUR	787
	mm	g	g	g			
0787 00 04	250	170	5	10,50			
0787 00 03	150	100	12	1	0,60		

Für Stiftsägeblätter und -kordeln mit 150mm Länge, mit glasfaserverstärktem Kunststoffgriff, verzinkter Bügel, mit Stiftsägeblatt

For saw blades and wire saws with 150mm length, with glass fibre reinforced plastic handle, frame zinc plated, with saw blade

Sägeblatt / Blade

Metallsägebogen Puk Hacksaw



Art.-Nr. / No.	↔		⚖		VE	EUR	788
	mm	"	g	g			
0788 00 01	150	6	130	5	5,95		
0788 00 02	200	8	190	5	7,40		
0788 00 03	250	10	250	5	8,40		

DIN 8350C, mit lackiertem Holzheft, Arbeitsflächen geschliffen

DIN 8350 C, lacquered, blade ground, wooden handle

Dreikanthohlschaber Three Square Hollow Ground Scraper



Art.-Nr. / No.	↔		⚖		VE	EUR	789
	mm	"	g	g			
0789 00 01	150	6	100	5	6,80		
0789 00 02	200	8	140	5	8,65		
0789 00 03	250	10	200	5	9,80		

Mit lackiertem Holzheft, Arbeitsflächen geschliffen

Lacquered, blade ground, wooden handle

Dreikantlöffelschaber Three Square Curved Bearing Scraper



Verschiedenes / Miscellaneous

Flachschaber Rectangular Scrapers

790

Art.-Nr. / No. mm " g VE EUR



DIN 8350 A, mit lackiertem Holzheft, Arbeitsflächen geschliffen

DIN 8350 A, lacquered, blade ground, wooden handle

Art.-Nr. / No.	mm	"	g	VE	EUR
0790 00 01	150	6	160	5	5,85
0790 00 02	200	8	230	5	7,50
0790 00 03	250	10	320	5	8,20

Dichtungsschaber Scraper for Gasket

840

Art.-Nr. / No. mm g VE EUR



Zum Entfernen von Dichtungsrückständen, besonders lang, Arbeitsflächen geschliffen, mit schlagfestem Kunststoffheft in schwarz

For removal of waste on washers and gaskets, blade ground, with impact resistant plastic handle

Art.-Nr. / No.	mm	g	VE	EUR
0840 00 01	250	110	5	12,50

Plastik-Ölkanne Plastic Oiler

793/1

Art.-Nr. / No. ccm g VE EUR



Mit Doppelpumpe, aus Kunststoff mit verstellbarem Rohr

With double-stroke pump, plastic

Art.-Nr. / No.	ccm	g	VE	EUR
0793 00 01	300	200	1	22,50

Präzisions-Ölstift Precision Oiler

793/2

Art.-Nr. / No. mm g VE EUR



Für enge Stellen / Gehäuse, Scharniere usw., stabiles Aluminium-Gehäuse, große Füllmenge, Hemdenclip, nur für Schmierstoffe

For precision oiling in tight and hard-to-reach places and machines, aluminium construction, for use with lubricants only, generous reservoir, convenient pocket clip

Art.-Nr. / No.	mm	g	VE	EUR
0793 00 02	5 - 5/8	40	1	7,50



Art.-Nr. / No.	ccm	g	VE	EUR	794
Satz komplett / Set 0794 00 05	500	1650	1	45,00	<p>Mit TWIN-LOCK System, verhindert Scheinschmierung (!), die Lebensversicherung für jede Lagerstelle; Fettpresse nach DIN 1283 - für 400g Kartusche oder 500ccm lose Fettfüllung; sehr stabile Industrierausführung, Anschlußgewinde M10 x 1, komplett mit 4-Backen Hydraulikmundstück, Düsenrohr, Panzerschlauch</p> <p>With TWIN-LOCK system, against dummy-lubrication (!), the life-insurance for every bearing point; grease gun according to DIN 1283 - for 400g cartridge or 500g bulk grease, robust industrial construction, connecting thread M10 x 1, complete with 4-jaw hydraulic coupler, angled spout, flexible hose</p>
Handhebel-Fettpresse / Lever Grease Gun 0794 00 01	500	1500	1	29,50	
Hydraulikmundstück / Hydraulic Coupler 0794 00 02		80	1	4,50	
Düsenrohr / Angled Spout 0794 00 03	150		30 10	1,90	
Panzerschlauch / Flexible Hose 0794 00 04	12 x 300		120 10	11,30	

Handhebel-Fettpresse TWIN-LOCK Lever Grease Gun TWIN LOCK

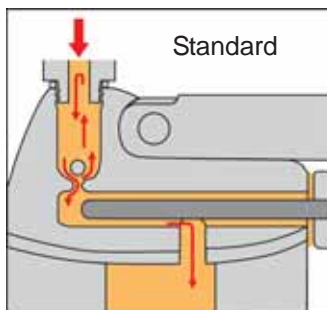

Standard

Fettpresse ohne Twin-Lock System - Fett fließt bei hohem Gegendruck in das Pressenrohr zurück (Scheinschmierung)
Grease Gun without TWIN-LOCK system - at high backpressure the grease flows back into the barrel (dummy-lubrication)

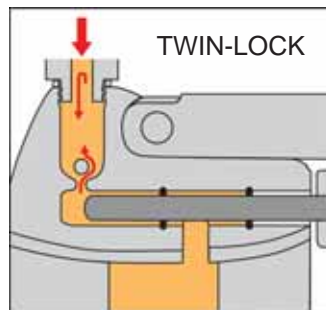

TWIN-LOCK

Fettpresse mit TWIN-LOCK System - 2 O-Ringe schützen den Präzisionskolben vor Verschleiß und verhindern den Rückfluss von Fett in das Rohr
Grease Gun with TWIN-LOCK system - 2 O-rings protect the precision made piston against abrasion and prevents the flow-back of grease into the barrel



Art.-Nr. / No.	mm	mm	mm	kg	EUR	815	
0815 00 01	115	66	140	7,8	252,00	<p>Parallelschraubstöcke, im Gesenk geschmiedet (Ganzstahl), gefräste Spannbacken, Spannbacken und Amboß gehärtet</p> <p>Parallel Vices forged (all steel), drop forged, large anvil, extra large opening, anvil and jaws hardened</p>	
0815 00 02	135	76	170	10,5	340,00		
0815 00 03	150	85	190	14,5	370,00		
0815 10 01	115				1 Stück / pc.	52,00	<p>Rohrspannbacken / Pipe Clamping Jaws</p>
0815 10 02	135				1 Stück / pc.	64,00	
0815 10 03	150				1 Stück / pc.	71,00	
0815 20 01	115				1 Paar / pair	86,00	<p>Kunststoff-Schutzbacken / Plastic Jaw Cabs</p>
0815 20 02	135				1 Paar / pair	98,00	
0815 20 03	150				1 Paar / pair	105,00	

Parallelschraubstöcke Parallel Vices



Art.-Nr. / No.	mm	mm	mm	kg	EUR	818
0818 00 01	100	53	100	5	88,00	<p>Ganzstahlschraubstöcke mit großem Amboß und eingearbeiteten Rohrspannbacken</p> <p>All Steel Vices with big anvil and integrated pipe gripping jaws</p>
0818 00 02	125	72	125	10,5	128,00	
0818 00 03	150	90	150	14,5	185,00	
0818 00 04	175	90	175	15	190,00	

Ganzstahlschraubstöcke All Steel Vices



Verschiedenes / Miscellaneous

Schweißpunktfräser Welding Spot Cutter



860

Fräskrone aus HSS, schwarz, mit 7mm Sechskant-schaft und auswechselbarer, doppelseitig verwend-barer Fräskrone, zum Ausfräsen von Karosserieteilen

Cutting crown HSS, black, with 7mm hexagon shank and changeable cutting crown for using on both sides, for welding spot reaming of car bodies

Ersatzkrone / Milling Crown
Ersatz-Zentrierstift / Spare Centering Pin

Art.-Nr. / No.	∅ mm	↔ mm	⚖ g	📦 VE	EUR
0860 00 01	10	72	23	5	14,50
0860 00 02				5	6,90
0860 00 03				5	4,00

Spezialbohrer HSS Co 5 Special Drill HSS Co 5



862

Extra stabile Konstruktion, besonders geeignet zum Ausbohren von Schweißpunkten und zum Bohren dünnwandiger Werkstücke; extrem hohe Präzision und gratfreies Bohren ohne Ankören; für Stahl-, Messing-, Aluminium-, Zink- und Kupferblech, Kunststoffplatten usw. Spezialanschliff mit Zentrums-pitze, ähnlich DIN 1412 E. Durchschnittliche Toleranz: h8 Oberfläche: blank / TiN

Extra stable special drill, suited for clean and burr-free milling of welding spots and thin-walled work, no centering, extreme high precision, for sheet steel, brass, aluminium, zinc, copper, plastic sheets etc., average tolerance: h8, surface: bright / TiN

Art.-Nr. / No.	∅ mm	↔ mm	⚖ g	📦 VE	EUR
0862 00 03	6	66	20	10	18,90
0862 00 04	8	80	24	10	19,50

Pneumatik Spotle Bohrer Pneumatic Spotle Drill



862/5

Wie 862, jedoch für Pneumatikmaschinen

As 862, but for pneumatic machines

Art.-Nr. / No.	∅ mm	↔ mm	⚖ g	📦 VE	EUR
0862 00 05	8,0 vario	44	20	10	21,-

Teleskopspiegel Telescopic Mirror

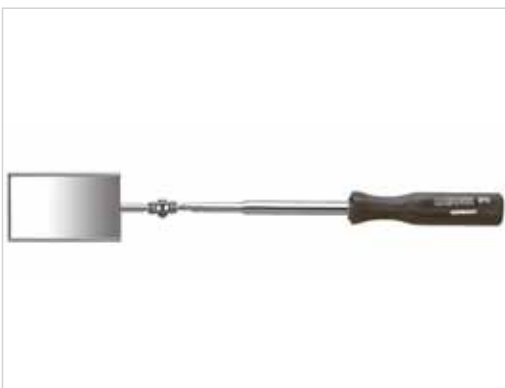

876

Mit verdrehsicherem Teleskop (!) und rechteckigem Spiegel, Länge 200 - 680mm, Spiegelglas aus-tauschbar, Schaft stufenlos verstellbar

With antirotation block (!) and rectangular interchan-geable glass, length 200 - 680mm, shank of the mir-ror is infinitely variable

Art.-Nr. / No.	∅ mm	↔ mm	⚖ g	📦 VE	EUR
0876 00 01	65x43	40-680	80	1	28,-
0876 00 91	Ersatzspiegel / Spare Mirror			1	10,95

Verdrehsicher / antirotation block

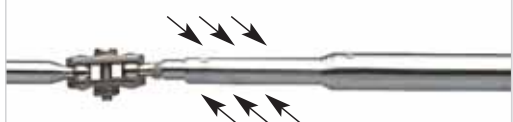

Art.-Nr. / No.	∅ mm	g VE	EUR	878
0878 00 01	150	300 1	7,95	

Magnet-Haftschale Magnetic Parts Bowl

Mit Gummischutz, aus rostfreiem Stahl, ideal für Arbeiten an Motor, Karrosserie usw., durch Gummiboden keine Kratzer, hält alle Schrauben und Kleinteile zusammen

For storage of nuts, bolts, screws, etc. whilst working, bowl has rubber covered magnetic base for affixing to metal objects such as vehicle bodywork, tool boxes etc. Magnetism transfers to inner surface of bowl to retain small metal parts, nuts, bolts, etc.



Art.-Nr. / No.	mm	g VE	EUR	880
0880 00 01	140	30 1	7,95	
0880 00 02		2 Stück / 2-pcs.	2,60	

Stiftleuchte Pen Light

Neue und äußerst praktische Stiftleuchte mit heller Lampe; dank ihrer geringen Abmessung überall hervorragend geeignet, wo viel Licht auf kleinstem Raum erforderlich ist, mit Halteclip für jede Hemdtasche, Stromversorgung mit 2 Batterien AAA

High quality aluminium pen with anodized finish for corrosion protection, with high intensity bulbs for longer battery life, with clip, with 2 AAA batteries



Ersatzbirne / Spare lamp

Art.-Nr. / No.	g VE	EUR	881
0881 00 01	700 1	48,00	

LED-Arbeitsleuchte mit NiMh-Akku LED Inspection Lamp

30 LEDs für maximale Lichtausbeute, Kaltlicht - kein Verbrennungsrisiko; NiMh-Akku; LED-Lebensdauer bis zu 100.000h; 1.000LUX; 5h Leuchtdauer; 4h Ladezeit; schlagfest; stoßunempfindlich; spritzwasser- und staubgeschützt (Schutzklasse IP 54); mit Tischladegerät (230V – 50Hz)

30 LED lights for strong and adjustable lighting; Ni-Mh batteries for high efficiency; long lasting LED (up to 100,000 hours); 1,000 lux; 5 hours autonomy; 4 hours charging time; fall and shock resistant (IK 9); waterproof (IP 54); resistant to products and solvents used in workshops; with charging base (230V - 50Hz)



30 LEDs / 30 LED torch lights



Tisch-Aufladestation / Charging base



Magnet- und Hakenhalterung / Magnet and hook



Steckschlüssel
Betätigungswerkzeuge
Sätze

Sockets
Socket Parts
Sets

Durchsteckknarren	Push-Thru-Type Ratchets
Umschaltknarren	Reversible Ratchets
Feinverzahnte Umschaltknarren	Reversible Ratchets, 72T
Verlängerungen	Extensions
Gleitgriffe	Sliding T-Handles
Einsätze in 1/4", 3/8", 1/2", 3/4" und 1"	Sockets with 1/4", 3/8", 1/2", 3/4" and 1" drive
Schraubendreher-Einsätze	Screwdriver Sockets
Steckschlüssel-Garnituren	Socket Sets
Kraft-Steckschlüssel	Impact Sockets



Inhalt Index



Steckschlüssel Socket Sets

Steckschlüssel / Socket Sets

Umschaltknarre mit Sicherheitsv. Reversible Ratchet with Safety Lock

□ 1/4"



2061/1

Nach DIN 3122 D / ISO 3315, mit Sicherheitsverbindung (Einsätze werden fixiert und können nicht selbständig herausfallen; Freigabe mit einer Hand nach Drücken des Löseknopfes); Chrom-Vanadium-Stahl 31 Cr-V 3 (1.2208), matt verchromt

According to DIN 3122 D / ISO 3315, with safety lock, sockets can only be removed by pushing the safety button; Chrome-Vanadium 31 Cr-V 3 (1.2208), chrome-plated

Art.-Nr. / No.	mm	g	VE	EUR
----------------	----	---	----	-----

2061 00 01	140	80	10	42,00
------------	-----	----	----	-------

Reparaturset / Repair Kit 2061 00 10		20	1	15,00
---	--	----	---	-------



Umschaltknarre, feinverzahnt Reversible Ratchet, 72-T

□ 1/4"

● 72T



2061/2

Feinverzahnt, Drehwinkel 5°, nach DIN 3122 D / ISO 3315, mit Sicherheitsverbindung (Einsätze werden fixiert und können nicht selbständig herausfallen; Freigabe mit einer Hand nach Drücken des Löseknopfes); Chrom-Vanadium-Stahl 31 Cr-V 3 (1.2208), matt verchromt

72T, actuation angle 5°, according to DIN 3122 D / ISO 3315, with safety lock, sockets can only be removed by pushing the safety button; Chrome-Vanadium 31 Cr-V 3 (1.2208), chrome-plated

Art.-Nr. / No.	mm	g	VE	EUR
----------------	----	---	----	-----

2061 00 02	140	80	10	44,00
------------	-----	----	----	-------

Reparaturset / Repair Kit 2061 00 11		20	1	15,00
---	--	----	---	-------



Mini-Umschaltknarre Mini Reversible Ratchet

□ 1/4"

● 72T



2062

Feinverzahnt, Drehwinkel 5°, für besonders enge Zwischenräume (Einstecktiefe mit Bit nur 25mm!), Chrom-Vanadium-Stahl 31 Cr-V 3 (1.2208), matt verchromt

72T, actuation angle 5°, with mini reversible ratchet for narrow spaces (insertion depth only 25,5mm!), Chrome-Vanadium 31 Cr-V 3 (1.2208), chrome-plated

Art.-Nr. / No.	mm	g	VE	EUR
----------------	----	---	----	-----

2062 00 03	50	20	10	29,80
------------	----	----	----	-------

Nur 25mm Tiefe inkl. Bit.
Only 25mm depth with bit.



Umschaltknarre, flexibel Reversible Ratchet, flexible

□ 1/4"

● 72T



2063

Feinverzahnt, Drehwinkel 5°, mit flexiblem Kopf, in Winkelstellung fixierbar, nach DIN 3122 D / ISO 3315, mit Sicherheitsverbindung (Einsätze werden fixiert und können nicht selbständig herausfallen; Freigabe mit einer Hand nach Drücken des Löseknopfes); Chrom-Vanadium-Stahl 31 Cr-V 3 (1.2208), matt verchromt

72T, actuation angle 5°, with flexible head, according to DIN 3122 D / ISO 3315, with safety lock, sockets can only be removed by pushing the safety button; Chrome-Vanadium 31 Cr-V 3 (1.2208), chrome-plated

Art.-Nr. / No.	mm	g	VE	EUR
----------------	----	---	----	-----

2063 00 01	120	80	10	44,00
------------	-----	----	----	-------

Reparaturset / Repair Kit 2063 00 10		20	1	15,00
---	--	----	---	-------



Art.-Nr. / No.	mm	g	VE	EUR	2064
2064 00 01	115	40	10	7,10	Nach DIN 3122 A / ISO 3315, Chrom-Vanadium-Stahl 31 Cr-V 3 (1.2208), matt verchromt According to DIN 3122 A / ISO 3315, Chrome-Vanadium 31 Cr-V 3 (1.2208), chrome-plated

Gleitgriff Sliding T-Handle

 1/4"

Art.-Nr. / No.	mm	"	g	VE	EUR	2065
2065 00 01	50	2	20	10	4,70	Nach DIN 3123 B / ISO 3316, Chrom-Vanadium-Stahl 31 Cr-V 3 (1.2208), matt verchromt According to DIN 3123 B / ISO 3316, Chrome-Vanadium 31 Cr-V 3 (1.2208), chrome-plated
2066 00 01	100	4	35	10	4,80	
2067 00 01	150	6	65	10	4,90	

Verlängerungen Extension Bars

 1/4"

Art.-Nr. / No.	mm	"	g	VE	EUR	2065/1
2065 10 01	50	2	20	10	4,90	Schwenkwinkel 5° nach jeder Seite, für engste Zwischenräume, nach DIN 3123 B / ISO 3316, Chrom-Vanadium-Stahl 31 Cr-V 3 (1.2208), matt verchromt 5° angular movement to each side, according to DIN 3123 B / ISO 3316, Chrome-Vanadium 31 Cr-V 3 (1.2208), chrome-plated
2065 10 02	100	4	35	10	4,90	



Schwenkbare Verlängerungen Flexible Extensions

 1/4"

Art.-Nr. / No.	mm	"	g	VE	EUR	2069
2069 00 01	150	6	50	10	9,50	Zum Überwinden von Kanten und bei beengten Platzverhältnissen, für Rechtsanzug, nach DIN 3123 B / ISO 3316, Chrom-Vanadium-Stahl 31 Cr-V 3 (1.2208), matt verchromt For getting over obstacles and borders, not for final tightening or initial loosening, according to DIN 3123 A / ISO 3316, Chrome-Vanadium 31 Cr-V 3 (1.2208), chrome-plated

Biegsame Verlängerung Flexible Extension

 1/4"

Art.-Nr. / No.	mm	g	VE	EUR	2068
2068 00 01	37	25	10	15,50	Nach DIN 3123 C / ISO 3316, Chrom-Vanadium-Stahl 31 Cr-V 3 (1.2208), matt verchromt According to DIN 3123 C / ISO 3316, Chrome-Vanadium 31 Cr-V 3 (1.2208), chrome-plated

Kardangelenk Universal Joint

 1/4"

Steckschlüssel / Socket Sets

Steckgriff Spinner Handle

□ 1/4"



2073

DIN 3123 E / ISO 3316, Kunststoffheft mit Innenvierkant, Chrom-Vanadium-Stahl 31 Cr-V 3 (1.2208), matt verchromt

DIN 3123 E / ISO 3316, handle with inner square, Chrome-Vanadium 31 Cr-V 3 (1.2208), chrome-plated

Art.-Nr. / No.

↔
mm

⚖️
g VE

EUR

2073 00 01

150

75 10

6,70

T-Griff mit 1/4"-Aufnahme T-Handle with 1/4"-coupler

□ 1/4"



2074

Ideal für Arbeiten im Motorenraum, an der Ölwanne, für Generatorhalter, Kühlmittelpumpe usw., mit 1/4"-Kardangeln mit Innenvierkant und 1/4"-Außenvierkant am T-Griff; Chrom-Vanadium-Stahl 31 Cr-V 3 (1.2208), matt verchromt

Perfect for all work in narrow spaces, e.g. for the oil pan, for generator holder, cooling pump, fuel pump etc., with 1/4" universal joint with inner square and 1/4" outer square on T-handle; Chrome-Vanadium 31 Cr-V 3 (1.2208), chrome-plated

Art.-Nr. / No.

↔
mm

↔
mm

⚖️
g VE

EUR

2074 00 01

500

150

100 10

19,50

Verbindungsstücke Socket Converters

3/8" 1/4"

1/4" 3/8"

2082 / 2083

DIN 3123 A / ISO 3316, Chrom-Vanadium-Stahl 31 Cr-V 3 (1.2208), matt verchromt

According to DIN 3123 A / ISO 3316, Chrome-Vanadium 31 Cr-V 3 (1.2208), chrome-plated

Art.-Nr. / No.

⊕ □

⚖️
g VE

EUR

2082 00 01

1/4"

3/8"

15 10

7,20

2083 00 02

3/8"

1/4"

30 10

7,20

Verbindungsstück für Bits Bit Converter

1/4" 1/4"

2084

Zum Einsetzen von 1/4"-Bits, nach DIN 3123 A / ISO 3316, mit Innen-4-kant- und Innen-6-kant-Aufnahme, mit Haltekugel für Bits, Chrom-Vanadium-Stahl 31 Cr-V 3 (1.2208), matt verchromt

For 1/4"-bits, according to DIN 3123 A / ISO 3316, with inside square and inside hexagon drive, with clamping ball for bits, Chrome-Vanadium 31 Cr-V 3 (1.2208), chrome-plated

Art.-Nr. / No.

⊕ ⬡

⚖️
g VE

EUR

2084 00 01

1/4"

1/4"

25 5

7,10

MTS-Adapter-Satz, 10-tlg. MTS-Set of Converters, 10 pcs.



2082 ModuFlex S

Alle Adapter von 1/4" bis auf 1/2" in einem Satz, mit ModuFlex-System, d.h. Einlage in blau / schwarz, entnehmbar für Werkstattwagen, Werkbänke usw., Einsätze aus Chrom-Vanadium-Stahl 31 Cr-V 3 (1.2208), matt verchromt, im stabilen Kunststoffkoffer

All converters from 1/4" up to 1/2" in one set, with ModuFlex-System (two-coloured hard foam module "see what is missing"), fits into workshop trolleys and benches; sockets made of Chrome-Vanadium 31 Cr-V 3 (1.2208), chrome-plated, in plastic case

Art.-Nr. / No.

⊕ □

⚖️
g VE

EUR

2082 60 01

1/4"

3/8"

350 1

39,00

3/8"

1/4"

3/8"

1/2"

1/2"

3/8"

Bits:

⊕ ⬡

1/4"

1/4"

3/8"

1/4"

3/8"

5/16"

1/2"

1/4"

1/2"

5/16"

1/2"

10mm

Art.-Nr. / No.	mm	mm	g	VE	EUR
2075 00 01	4	25	10	10	3,10
2075 00 02	4,5	25	10	10	3,10
2075 00 03	5	25	10	10	3,10
2075 00 04	5,5	25	10	10	3,10
2075 00 05	6	25	10	10	3,10
2075 00 06	7	25	15	10	3,10
2075 00 07	8	25	15	10	3,10
2075 00 08	9	25	15	10	3,10
2075 00 09	10	25	20	10	3,10
2075 00 10	11	25	25	10	3,10
2075 00 11	12	25	30	10	3,50
2075 00 12	13	25	37	10	3,50
2075 00 13	14	25	40	10	3,50
2075 01 01	1/8	25	10	10	3,10
2075 01 02	5/32	25	10	10	3,10
2075 01 03	3/16	25	10	10	3,10
2075 01 04	7/32	25	10	10	3,10
2075 01 05	1/4	25	10	10	3,10
2075 01 06	9/32	25	15	10	3,10
2075 01 07	5/16	25	15	10	3,10
2075 01 08	11/32	25	15	10	3,10
2075 01 09	3/8	25	20	10	3,10
2075 01 10	7/16	25	25	10	3,10
2075 01 11	1/2	25	30	10	3,75

2075

Steckschlüssel-Einsätze Hexagon Sockets

Passend für Außensechskant-Schrauben, Sechskant-Profil, nach DIN 3120 / ISO 1174, mit Kugelfangloch, für Handbetätigung, Chrom-Vanadium-Stahl 31 Cr-V 3 (1.2208), matt verchromt

For outside hexagon screws, 6-pt., 1/4"-square drive acc. to DIN 3120 / ISO 1174, with hole for accessories, for manual drive, Chrome-Vanadium 31 Cr-V 3 (1.2208), chrome-plated



2075 01 50	10-tlg. / pcs.	210	1	18,95
------------	----------------	-----	---	--------------

Satz 1/4"-Steckschlüssel-Einsätze auf Klemmleiste, zum Befestigen an Werkstattwagen oder -wänden, mit 14 verschiebbaren Haltefedern

2075 01 60	10-tlg. / pcs.	210	1	18,95
------------	----------------	-----	---	--------------

Set of sockets on socket rail, for fitting in tool trolleys or on tool bars, with 14 socket clips

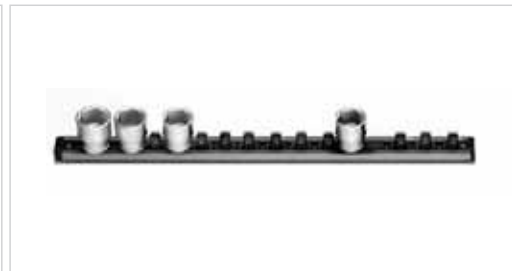

2075 01 99	leer / empty	70	1	2,90
------------	--------------	----	---	-------------

Klemmleiste für 14 Steckschlüssel-Einsätze, verchromt, poliert

Socket Rail, with 14 socket clips, chrome-plated, polished



Art.-Nr. / No.	mm	mm	g	VE	EUR
2076 00 01	0,8 x 4	25	10	10	5,10
2076 00 02	1,0 x 5,5	25	10	10	5,10
2076 00 03	1,2 x 7	25	10	10	5,10

2076

Schraubendreher-Einsätze Screwdriver Sockets

Passend für Schlitzschrauben, DIN 3127 / ISO 2351, für Handbetätigung, Klinge schwarz, aus legiertem Sonderstahl, Klinge nach DIN 5264 / ISO 2380-1, Chrom-Vanadium-Stahl 31 Cr-V 3 (1.2208), matt verchromt

For slotted screws, DIN 3120 / ISO 1174, for manual drive, with black point tip, high grade tool steel, tip acc. to DIN 5264 / ISO 2380-1, Chrome-Vanadium 31 Cr-V 3 (1.2208), chrome-plated



Art.-Nr. / No.	PH	mm	g	VE	EUR
2077 00 01	1	25	10	10	5,10
2077 00 02	2	25	10	10	5,10
2077 00 03	3	25	10	10	5,10
2077 00 04	4	25	10	10	5,10

2077

Schraubendreher-Einsätze Screwdriver Sockets

Passend für Kreuzschlitzschrauben Philips-Recess (DIN 3128), für Handbetätigung, Klinge schwarz, aus legiertem Sonderstahl, Klinge nach DIN 5260 PH, Chrom-Vanadium-Stahl 31 Cr-V 3 (1.2208), matt verchromt

For cross slot screws Philips Recess (DIN 3128), for manual drive, with black point tip, high grade tool steel, tip acc. to DIN 5260 PH, Chrome-Vanadium 31 Cr-V 3 (1.2208), chrome-plated



Steckschlüssel / Socket Sets

Schraubendreher-Einsätze Screwdriver Sockets

1/4"



2077

Passend für Kreuzschlitzschrauben Supa-Pozidriv, für Handbetätigung, Klinge schwarz, aus legiertem Sonderstahl, Klinge nach DIN 5260 PZ, Chrom-Vanadium-Stahl 31 Cr-V 3 (1.2208), matt verchromt

For cross slot screws Supa-Pozidriv, for manual drive, with black point tip, high grade tool steel, tip acc. to DIN 5260 PZ, Chrome-Vanadium 31 Cr-V 3 (1.2208), chrome-plated

Art.-Nr. / No.	PZ	mm	g	VE	EUR
2077 00 11	1	25	10	10	5,10
2077 00 12	2	25	10	10	5,10
2077 00 13	3	25	10	10	5,10

Schraubendreher-Einsätze Screwdriver Sockets

1/4"



2078

Passend für Innensechskantschrauben (DIN 7426 / ISO 3109), für Handbetätigung, Klinge schwarz, aus legiertem Sonderstahl, Chrom-Vanadium-Stahl 31 Cr-V 3 (1.2208), matt verchromt

For inside hexagon screws (DIN 7426 / ISO 3109), for manual drive, with black point tip, high grade tool steel, Chrome-Vanadium 31 Cr-V 3 (1.2208), chrome-plated

Art.-Nr. / No.	mm	mm	g	VE	EUR
2078 00 01	3	32	10	10	5,10
2078 00 02	4	32	10	10	5,10
2078 00 03	5	32	10	10	5,10
2078 00 04	6	32	10	10	5,10
2078 00 05	8	32	10	10	5,10
2078 00 06	4	55	10	10	5,10

Schraubendreher-Einsätze Screwdriver Sockets

1/4"



2090

Passend für Außen-TORX-Schrauben, für Handbetätigung, Chrom-Vanadium-Stahl 31 Cr-V 3 (1.2208), matt verchromt

For outside TORX-screws, for manual drive, Chrome-Vanadium 31 Cr-V 3 (1.2208), matt chrome-plated

Art.-Nr. / No.	E	mm	g	VE	EUR
2090 00 01	4	25,5	10	10	4,20
2090 00 02	5	25,5	10	10	4,20
2090 00 03	6	25,5	12	10	4,20
2090 00 04	7	25,5	12	10	4,20
2090 00 05	8	25,5	12	10	4,20
2090 00 06	10	25,5	16	10	4,30
2090 00 07	11	25,5	22	10	4,30

Schraubendreher-Einsätze Screwdriver Sockets

1/4"



2092

Passend für Innen-TORX-Schrauben, für Handbetätigung, Chrom-Vanadium-Stahl 31 Cr-V 3 (1.2208), matt verchromt

For inside TORX-screws, for manual drive, Chrome-Vanadium 31 Cr-V 3 (1.2208), matt chrome-plated

Art.-Nr. / No.	TX	mm	g	VE	EUR
2092 00 01	8	32,5	14	10	5,50
2092 00 02	10	32,5	14	10	5,50
2092 00 03	15	32,5	14	10	5,50
2092 00 04	20	32,5	12	10	6,05
2092 00 05	25	32,5	12	10	6,05
2092 00 06	27	32,5	14	10	6,35
2092 00 07	30	32,5	14	10	6,35
2092 00 08	40	32,5	14	10	6,35

Schraubendreher-Einsätze Screwdriver Sockets

1/4"







2093

Passend für Tamper-Resistant-TORX-Schrauben (Innen-TORX-Schrauben mit Zapfenführung), für Handbetätigung, Chrom-Vanadium-Stahl 31 Cr-V 3 (1.2208), matt verchromt





For Tamper resistant TORX screws (inside TORX screws with pin), for manual drive, Chrome-Vanadium 31 Cr-V 3 (1.2208), chrome-plated

Art.-Nr. / No.	TX	mm	g	VE	EUR
2093 00 01	8	37	14	10	5,50
2093 00 02	10	37	14	10	5,50
2093 00 03	15	37	14	10	5,50
2093 00 04	20	37	14	10	6,05
2093 00 05	25	37	14	10	6,05
2093 00 06	27	37	14	10	6,35
2093 00 07	30	37	14	10	6,35
2093 00 08	40	37	14	10	6,35

Art.-Nr. / No.	   				EUR	2094
	T	mm	g	VE		
2094 00 01	10	37	14	10	5,90	Passend für Innen-5-Stern-Schrauben mit Zapfen (IP-Profil), für Lichtmaschine, Motorsteuerung, Luftmengenmesser, Türverkleidung usw. bei VW-Audi, Ford, Volvo, Mercedes Benz sowie Steckpumpen an Mercedes Benz Actros und Atego; Klinge schwarz, aus legiertem Sonderstahl, Klinge nach DIN 5260 PH, Chrom-Vanadium-Stahl 31 Cr-V 3 (1.2208), matt verchromt For the operation of inside 5-star screws with pin, for dynamo, engine control, air flow sensor etc. on VW-Audi, Ford, Volvo, Mercedes Benz as well as for the screwed connection of the plug-in pump on Mercedes Benz Actros and Atego; with black point tip, high grade tool steel, tip acc. to DIN 5260 PH, Chrome-Vanadium 31 Cr-V 3 (1.2208), chrome-plated
2094 00 02	15	37	14	10	5,90	
2094 00 03	20	37	14	10	5,90	
2094 00 04	25	37	14	10	6,10	
2094 00 05	27	37	14	10	6,10	
2094 00 06	30	37	14	10	6,10	
2094 00 07	40	37	14	10	6,50	
2094 00 08	50	37	14	10	6,50	
2094 00 10	T 10-50	37	115	1	49,50	8-tlg. Satz auf Klemmschiene / 8-pcs. set on socket rail

Schraubendreher-Einsätze Screwdriver Sockets



Art.-Nr. / No.	   				EUR	2080
	mm	mm	g	VE		
2080 00 01	4	50	12	10	8,90	Extra tief, Maße nach DIN 3124 / ISO 2725, passend für Außen-Sechskantschrauben, ideal für Muttern auf langen Gewindebolzen und für tief liegende Schrauben, Chrom-Vanadium-Stahl 31 Cr-V 3 (1.2208), matt verchromt Extra deep, according to DIN 3124 / ISO 2725, for outside hexagon bolts, perfect for nuts on long threaded bolts and for deep lying nuts, Chrome-Vanadium 31 Cr-V 3 (1.2208), chrome-plated
2080 00 02	4,5	50	13	10	8,90	
2080 00 03	5	50	14	10	8,90	
2080 00 04	5,5	50	16	10	8,90	
2080 00 05	6	50	16	10	8,90	
2080 00 06	7	50	20	10	8,90	
2080 00 07	8	50	25	10	8,90	
2080 00 08	9	50	30	10	8,90	
2080 00 09	10	50	35	10	8,90	
2080 00 10	11	50	45	10	8,90	
2080 00 11	12	50	50	10	8,90	
2080 00 12	13	50	65	10	8,90	
2080 00 13	14	50	70	10	8,90	

Steckschlüssel-Einsätze, lang Hexagon Sockets, long type



Präzises Schmiedeverfahren / Precision Forging

Voll-galvanische Behandlung (Vernickeln und Verchromen für langanhaltenden Rostschutz) - garantiert Chrom VI-frei
 Full galvanic treatment (nickel and chrome plating for long rust prevention) - guaranteed free of Chrom VI



Steckschlüssel / Socket Sets

1/4"-Satz, 16-tlg. 1/4"-Socket Set, 16 pcs.

















1/4" 



2115

Satz mit den gängigsten 1/4"-Steckschlüssel-einsätzen und -Werkzeugen, mit ABS-Einlage, im stabilen Metallkasten

Tool Set with the most popular 1/4" sockets and tools, with ABS-module, in metal case

Art.-Nr. / No.	g	VE	EUR	Art.-Nr. / No.	g	VE	EUR
2115 00 01	700	1	55,00	2115 01 01	700	1	55,00
2061				2061			
2064	 115mm			2064	 115mm		
2066	 100mm			2066	 100mm		
2068				2068			
2073				2073			
 2075	4; 4,5; 5; 5,5; 6; 7; 8; 9; 10; 11; 13mm			 2075	1/8; 5/32; 3/16; 7/32; 1/4; 9/32; 5/16; 11/32; 3/8; 7/16; 1/2"AF		
2115 00 02	700	1	57,00	2115 01 02	700	1	57,00
2061	 Feinverzahnt / 72T			2061	 Feinverzahnt / 72T		
2115 00 03	700	1	57,00	2115 01 03	700	1	57,00
2063	 Flex. Kopf / Flex type			2063	 Flex. Kopf / Flex type		

1/4"-Satz, 28-tlg. 1/4"-Socket Set, 28 pcs.























1/4"    



2135

Mit Schraubendreher-Einsätzen für Schlitzschrauben (DIN 3127 / ISO 2351), Kreuzschlitzschrauben Philips-Recess (DIN 3128) und Innensechskantschrauben (DIN 7426 / ISO 3109), mit ABS-Einlage, in Metallkasten

With screwdriver sockets for slotted screws (DIN 3120 / ISO 1174), cross slot screws Philips Recess (DIN 3128) and inside hexagon screws (DIN 7426 / ISO 3109), with ABS-module, in metal case

Art.-Nr. / No.	g	VE	EUR	Art.-Nr. / No.	g	VE	EUR
2135 00 01	850	1	85,00	2135 01 01	850	1	85,00
2061				2061			
2064	 115mm			2064	 115mm		
2065	 50mm, 100mm			2065	 50mm, 100mm		
2068				2068			
2073				2073			
 2075	4; 4,5; 5; 5,5; 6; 7; 8; 9; 10; 11; 13mm			 2075	1/8; 5/32; 3/16; 7/32; 1/4; 9/32; 5/16; 11/32; 3/8; 7/16; 1/2"AF		
 2076	4; 5,5; 7mm			 2076	4; 5,5; 7mm		
 2077	PH 1, 2, 3			 2077	PH 1, 2, 3		
 2078	3, 4, 5, 6, 8mm			 2078	3, 4, 5, 6, 8mm		
2135 00 02	850	1	87,00	2135 01 02	850	1	87,00
2061	 Feinverzahnt / 72T			2061	 Feinverzahnt / 72T		
2135 00 03	850	1	87,00	2135 01 03	850	1	87,00
2063	 Flex. Kopf / Flex type			2063	 Flex. Kopf / Flex type		

1/4"-Satz TORX, 32-tlg. 1/4"-Socket Set TORX, 32 pcs.

















1/4"  



2136

Mit Schraubendreher-Einsätzen für Außen- und Innen-TORX-Schrauben, Chrom-Vanadium-Stahl 31 Cr-V 3 (1.2208), matt verchromt, mit ABS-Einlage, in Metallkasten

With screwdriver sockets for inside and outside TORX screws, Chrome-Vanadium 31 Cr-V 3 (1.2208), matt chrome-plated, with ABS-module, in metal case

Art.-Nr. / No.	g	VE	EUR	Art.-Nr. / No.	g	VE	EUR
2136 00 01	900	1	90,00	2136 01 01	900	1	90,00
2061				2061			
2064	 115mm			2064	 115mm		
2065	 50mm, 100mm			2065	 50mm, 100mm		
2068				2068			
2073				2073			
 2075	4; 4,5; 5; 5,5; 6; 7; 8; 9; 10; 11; 13mm			 2075	1/8; 5/32; 3/16; 7/32; 1/4; 9/32; 5/16; 11/32; 3/8; 7/16; 1/2"AF		
 2090	E 4, 5, 6, 7, 8, 10, 11			 2090	E 4, 5, 6, 7, 8, 10, 11		
 2092	TX 8, 10, 15, 20, 25, 27, 30, 40			 2092	TX 8, 10, 15, 20, 25, 27, 30, 40		
2136 00 02	900	1	92,00	2136 01 02	900	1	92,00
2061	 Feinverzahnt / 72T			2061	 Feinverzahnt / 72T		
2136 00 03	900	1	92,00	2136 01 03	900	1	92,00
2063	 Flex. Kopf / Flex type			2063	 Flex. Kopf / Flex type		

Art.-Nr. / No.	g	VE	EUR	Art.-Nr. / No.	g	VE	EUR
2136 60 01	900	1	85,00	2136 61 01	900	1	85,00
2061				2061			
2064		115mm		2064		115mm	
2065		50mm, 100mm		2065		50mm, 100mm	
2068				2068			
2073				2073			
2075		4; 4,5; 5; 5,5; 6; 7; 8; 9; 10; 11; 13mm		2075		1/8; 5/32; 3/16; 7/32; 1/4; 9/32; 5/16; 11/32; 3/8; 7/16; 1/2"AF	
2090		E 4, 5, 6, 7, 8, 10, 11		2090		E 4, 5, 6, 7, 8, 10, 11	
2092		TX 8, 10, 15, 20, 25, 27, 30, 40		2092		TX 8, 10, 15, 20, 25, 27, 30, 40	
2136 60 02	900	1	85,00	2136 61 02	900	1	85,00
2061		Feinverzahnt / 72T		2061		Feinverzahnt / 72T	
2136 60 03	900	1	88,00	2136 61 03	900	1	88,00
2063		Flex. Kopf / Flex type		2063		Flex. Kopf / Flex type	

2136

1/4"-Satz TORX, 32-tlg. 1/4" Socket Set TORX, 32 pcs.

Mit TORX-Steckschlüsseleinsätzen für Innen- und Außen-TORX-Schrauben, ModuFlex-System Größe S, entnehmbar für Werkstattwagen, Chrom-Vanadium-Stahl 31 Cr-V 3 (1.2208), matt verchromt, im stabilen Kunststoffkoffer

With TORX-sockets for inside and outside screws, ModuFlex-System size S, fits into workshop trolleys, Chrome-Vanadium 31 Cr-V 3 (1.2208), chrome-plated, in plastic case

ModuFlex S



ModuFlex: Ein System für unbegrenzten Einsatz.
ModuFlex: One system for unlimited applications.

ModuFlex

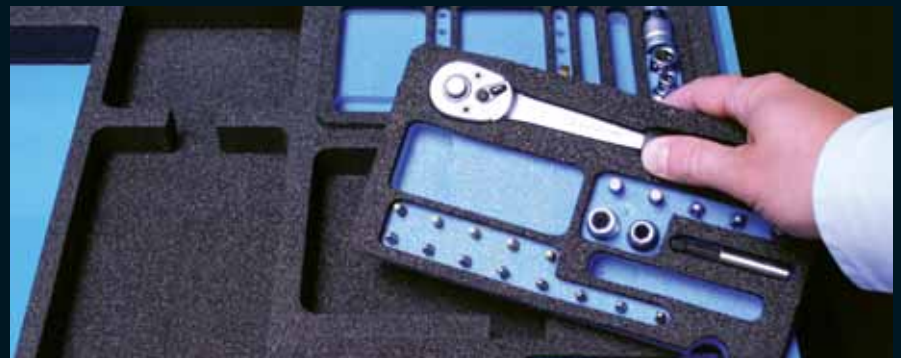

Art.-Nr. / No.	g	VE	EUR	Art.-Nr. / No.	g	VE	EUR
2150 00 01	700	1	55,00	2150 01 01	700	1	55,00
2061				2061			
2064		115mm		2064		115mm	
2066		100mm		2066		100mm	
2068				2068			
2073				2073			
2075		4; 4,5; 5; 5,5; 6; 7; 8; 9; 10; 11; 13mm		2075		1/8; 5/32; 3/16; 7/32; 1/4; 9/32; 5/16; 11/32; 3/8; 7/16; 1/2"AF	
2150 00 02	700	1	57,00	2150 01 02	700	1	57,00
2061		Feinverzahnt / 72T		2061		Feinverzahnt / 72T	
2150 00 03	700	1	57,00	2150 01 03	700	1	57,00
2063		Flex. Kopf / Flex type		2063		Flex. Kopf / Flex type	

2150

1/4"-Satz, 16-tlg. 1/4"-Socket Set, 16 pcs.

Sehr kompakter Satz mit den gängigsten 1/4"-Steckschlüsseleinsätzen und -Werkzeugen, ideal für Fahrrad und Haushalt, mit ABS-Einlage, in formschöner Kunststoffkassette

Mini Tool Set with the most popular 1/4" sockets and tools, perfect for bicycle and household, with ABS-module, in plastic case



Steckschlüssel / Socket Sets

Umschaltknarre mit Sicherheitsv. Reversible Ratchet with Safety Lock

3/8"



3061/1

Nach DIN 3122 D / ISO 3315, mit Sicherheitsverbindung (Einsätze werden fixiert und können nicht selbständig herausfallen; Freigabe mit einer Hand nach Drücken des Löseknopfes); Chrom-Vanadium-Stahl 31 Cr-V 3 (1.2208), matt verchromt

According to DIN 3122 D / ISO 3315, with safety lock, sockets can only be removed by pushing the safety button; Chrome-Vanadium 31 Cr-V 3 (1.2208), matt chrome-plated

Art.-Nr. / No.	mm	g	VE	EUR
----------------	----	---	----	-----

3061 00 01	200	260	10	52,00
------------	-----	-----	----	-------

Reparaturatz / Repair Kit 3061 00 10		60	1	24,95
---	--	----	---	-------



Umschaltknarre, feinverzahnt Reversible Ratchet, 72-T

3/8"

72T



3061/2

Feinverzahnt, Drehwinkel 5°, nach DIN 3122 D / ISO 3315, mit Sicherheitsverbindung (Einsätze werden fixiert und können nicht selbständig herausfallen; Freigabe mit einer Hand nach Drücken des Löseknopfes); Chrom-Vanadium-Stahl 31 Cr-V 3 (1.2208), matt verchromt

72T, actuation angle 5°, according to DIN 3122 D / ISO 3315, with safety lock, sockets can only be removed by pushing the safety button; Chrome-Vanadium 31 Cr-V 3 (1.2208), matt chrome-plated

Art.-Nr. / No.	mm	g	VE	EUR
----------------	----	---	----	-----

3061 00 02	200	260	10	55,00
------------	-----	-----	----	-------

Reparaturatz / Repair Kit 3061 00 11		60	1	24,95
---	--	----	---	-------



Gleitgriff Sliding T-Handle

3/8"



3064

Nach DIN 3122 A / ISO 3315, Chrom-Vanadium-Stahl 31 Cr-V 3 (1.2208), matt verchromt

According to DIN 3122 A / ISO 3315, Chrome-Vanadium 31 Cr-V 3 (1.2208), chrome-plated

Art.-Nr. / No.	mm	g	VE	EUR
----------------	----	---	----	-----

3064 00 01	200	170	10	13,75
------------	-----	-----	----	-------

Verlängerungen Extensions

3/8"



3/8"



3065 / 3066

Nach DIN 3123 B / ISO 3316, Chrom-Vanadium-Stahl 31 Cr-V 3 (1.2208), matt verchromt

According to DIN 3123 B / ISO 3316, Chrome-Vanadium 31 Cr-V 3 (1.2208), chrome-plated

Mit Schwenkwinkel 5° nach jeder Seite, für engste Zwischenräume, nach DIN 3123 B / ISO 3316, Chrom-Vanadium-Stahl 31 Cr-V 3, matt verchromt

With 5° angular movement to each side, according to DIN 3123 B / ISO 3316, Chrome-Vanadium 1.2208, chrome-plated

Art.-Nr. / No.	mm	"	g	VE	EUR
----------------	----	---	---	----	-----

3065 00 01	125	5	110	10	9,50
3066 00 01	250	10	210	10	12,95

3065 10 01	75	3	68	10	9,95
3065 10 02	125	5	190	10	11,50

Art.-Nr. / No.	↔		⚖		EUR	3067
	mm	"	g	VE		
3067 00 01	75	3	80	10	10,75	Verhindert versehentliches Herunterfallen von Steckschlüssel-Einsätzen an schwer zugänglichen Stellen, einfache und schnelle Freigabe des aufgesteckten Werkzeuges durch Zurückziehen des gerändelten Ringes, Oberfläche verchromt, Chrom-Vanadium-Stahl 31 Cr-V 3 (1.2208), matt verchromt Avoids the accidental dropping of sockets during works in narrow places, easy and quick release of the socket by push-back of the knurled ring, Chrome-Vanadium 31 Cr-V 3 (1.2208), chrome-plated
3067 00 02	150	6	140	10	11,95	

Verriegelbare Verlängerung

Locking Type Extension

 3/8"

Art.-Nr. / No.	↔		⚖		EUR	3068
	mm	"	g	VE		
3068 00 01	58		75	10	20,50	Nach DIN 3123 C / ISO 3316, Chrom-Vanadium-Stahl 31 Cr-V 3 (1.2208), matt verchromt According to DIN 3123 C / ISO 3316, Chrome-Vanadium 31 Cr-V 3 (1.2208), chrome-plated

Kardangeln

Universal Joint

 3/8"

Art.-Nr. / No.	↔		⚖		EUR	3070
	mm	"	g	VE		
3070 00 01	300		260	5	19,95	Nach DIN 3122 B / ISO 3315, Chrom-Vanadium-Stahl 31 Cr-V 3 (1.2208), matt verchromt According to DIN 3122 B / ISO 3315, Chrome-Vanadium 31 Cr-V 3 (1.2208), chrome-plated

Kurbel

Speed Brace

 3/8"

Art.-Nr. / No.	↔		⚖		EUR	3072
	mm	"	g	VE		
3072 00 01	225		215	5	29,00	Nach DIN 3122 F / ISO 3315, Chrom-Vanadium-Stahl 31 Cr-V 3 (1.2208), matt verchromt According to DIN 3122 F / ISO 3315, Chrome-Vanadium 31 Cr-V 3 (1.2208), chrome-plated

Gelenkgriff

Swivel Handle

 3/8"

Art.-Nr. / No.	↔		⚖		EUR	3074
	mm	mm	g	VE		
3074 00 01	150	75	120	10	22,50	Ideal für Arbeiten im Motorenraum, an der Ölwanne, für Generatorhalter, Kühlmittelpumpe usw., mit 3/8"-Kardangeln mit Innenvierkant und 3/8"-Außenvierkant am T-Griff; Chrom-Vanadium-Stahl 31 Cr-V 3 (1.2208), matt verchromt Perfect for all work in narrow spaces, e.g. for the oil pan, for generator holder, cooling pump, fuel pump etc., with 3/8" universal joint with inner square and 3/8" outer square on T-handle; Chrome-Vanadium 31 Cr-V 3 (1.2208), chrome-plated

T-Griff mit 3/8"-Aufnahme

T-Handle with 3/8"-coupler

 3/8"

Steckschlüssel / Socket Sets

Verbindungsstücke Socket Converters



3082 / 3083

DIN 3123 A / ISO 3316, Chrom-Vanadium-Stahl
31 Cr-V 3 (1.2208), matt verchromt

According to DIN 3123 A / ISO 3316, Chrome-Vanadium 31 Cr-V 3 (1.2208), chrome-plated

Art.-Nr. / No.	⊕	□	⚖	📦	g VE	EUR
3082 00 01	3/8"	1/2"	50	10	7,75	
3083 00 01	1/2"	3/8"	50	10	7,75	

Verbindungsstücke für Bits Bit Converters



3086

Zum Einsetzen von 1/4"-Bits, nach DIN 3123 A / ISO 3316, mit Innen-4-kant- und Innen-6-kant-Aufnahme, mit Haltekugel für Bits, Chrom-Vanadium-Stahl 31 Cr-V 3 (1.2208), matt verchromt

For 1/4"-bits, according to DIN 3123 A / ISO 3316, with inside square and inside hexagon drive, with clamping ball for bits, Chrome-Vanadium 31 Cr-V 3 (1.2208), chrome-plated

Art.-Nr. / No.	⊕	⬡	⚖	📦	g VE	EUR
3086 00 01	3/8"	1/4"	50	10	8,60	
3086 00 02	3/8"	5/16"	50	10	8,60	

Steckschlüssel-Einsätze Sockets



3075





Passend für Außensechskant-Schrauben, Sechskant- bzw. Zwölfkant-Profil, nach DIN 3120 / ISO 1174, für Handbetätigung, Chrom-Vanadium-Stahl 31 Cr-V 3 (1.2208), matt verchromt

For outside hexagon screws, 6-pt. and 12-pt., 3/8"-square drive acc. to DIN 3120 / ISO 1174, for manual drive, Chrome-Vanadium 31 Cr-V 3 (1.2208), matt chrome-plated

Art.-Nr. / No.	⊕	↔	⚖	📦	g VE	EUR
3075 00 18	6	28	25	10	4,95	
3075 00 19	7	28	30	10	4,95	
3075 00 20	8	28	30	10	4,95	
3075 00 21	9	28	30	10	4,95	
3075 00 05	10	28	30	10	4,95	
3075 00 06	11	28	30	10	4,95	
3075 00 07	12	28	30	10	4,95	
3075 00 08	13	28	35	10	4,95	
3075 00 09	14	28	35	10	4,95	
3075 00 10	15	28	40	10	5,10	
3075 00 11	16	30	55	10	5,10	
3075 00 12	17	30	55	10	5,10	
3075 00 13	18	30	55	10	5,10	
3075 00 14	19	30	60	10	5,10	
3075 00 15	20	32	60	10	5,30	
3075 00 16	21	32	75	10	5,30	
3075 00 17	22	32	75	10	5,30	

Art.-Nr. / No.	⊕	↔	⚖	📦	g VE	EUR
3075 01 01	1/4	28	25	10	5,15	
3075 01 02	5/16	28	30	10	5,15	
3075 01 03	11/32	28	30	10	5,15	
3075 01 04	3/8	28	30	10	5,15	
3075 01 05	7/16	28	30	10	5,15	
3075 01 06	1/2	28	35	10	5,15	
3075 01 07	9/16	28	35	10	5,15	
3075 01 08	19/32	28	40	10	5,35	
3075 01 09	5/8	30	40	10	5,35	
3075 01 10	11/16	30	45	10	5,35	
3075 01 11	3/4	30	60	10	5,35	
3075 01 12	25/32	32	65	10	5,85	
3075 01 13	13/16	32	75	10	5,85	
3075 01 14	7/8	32	75	10	5,85	



Art.-Nr. / No.	⊕	↔	⚖	📦	g VE	EUR
3075 00 01	6	28	25	10	4,95	
3075 00 02	7	28	30	10	4,95	
3075 00 03	8	28	30	10	4,95	
3075 00 04	9	28	30	10	4,95	
3075 00 30	10	28	30	10	4,95	
3075 00 31	11	28	30	10	4,95	
3075 00 32	12	28	30	10	4,95	
3075 00 33	13	28	35	10	4,95	
3075 00 34	14	28	35	10	4,95	
3075 00 35	15	28	40	10	5,10	
3075 00 36	16	30	55	10	5,10	
3075 00 37	17	30	55	10	5,10	
3075 00 38	18	30	55	10	5,10	
3075 00 39	19	30	60	10	5,10	
3075 00 40	20	32	60	10	5,30	
3075 00 41	21	32	75	10	5,30	
3075 00 42	22	32	75	10	5,30	

Art.-Nr. / No.							3075
		g	VE	EUR			
3075 01 50	10-tlg. / pcs. 10; 11; 12; 13; 14; 15; 16; 17; 18; 19mm		400	1	48,50		Satz 3/8"-Steckschlüssel-Einsätze auf Klemmleiste, zum Befestigen an Werkstattwagen oder -wänden, mit 14 verschiebbaren Haltefedern
3075 01 51	10-tlg. / pcs. 10; 11; 12; 13; 14; 15; 16; 17; 18; 19mm		400	1	48,50		Set of sockets on socket rail, for fitting in tool trolleys or on tool bars, with 14 socket clips
3075 01 60	11-tlg. / pcs. 3/8; 7/16; 1/2; 9/16; 19/32; 5/8; 11/16; 3/4; 25/32; 13/16; 7/8" AF		410	1	53,50		

Satz Steckschlüssel-Einsätze

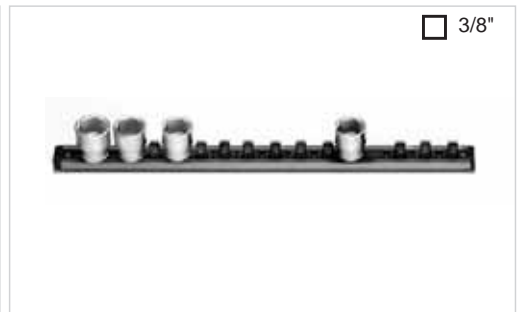
Set of Sockets





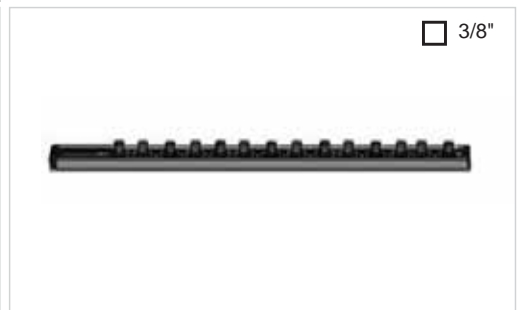

Art.-Nr. / No.							3075
		mm	VE	EUR			
3075 01 99	leer / empty	70	10	3,50			Klemmleiste für 14 Steckschlüssel-Einsätze, verchromt, poliert
							Socket Rail, with 14 socket clips, chrome-plated, polished

Klemmleiste leer

Socket Rail, empty







Art.-Nr. / No.							3076
	mm	mm	mm	VE	EUR		
3076 00 01	1,0 x 7	60	57	10	9,20		Passend für Schlitzschrauben, DIN 3127 / ISO 2351, für Handbetätigung, Klinge schwarz, aus legiertem Sonderstahl, Klinge nach DIN 5264 / ISO 2380-1, Chrom-Vanadium-Stahl 31 Cr-V 3 (1.2208), matt verchromt, poliert
3076 00 02	1,2 x 8	60	59	10	9,20		
3076 00 03	1,6 x 9	60	61	10	9,20		
							For slotted screws, DIN 3120 / ISO 1174, for manual drive, with black point tip, high grade tool steel, tip acc. to DIN 5264 / ISO 2380-1, Chrome-Vanadium 31 Cr-V 3 (1.2208), chrome-plated, polished

Schraubendreher-Einsätze

Screwdriver Sockets







Art.-Nr. / No.							3077
	PH	mm	mm	VE	EUR		
3077 00 01	1	52	51	10	9,20		Passend für Kreuzschlitzschrauben Philips-Recess (DIN 3128), für Handbetätigung, Klinge schwarz, aus legiertem Sonderstahl, Klinge nach DIN 5260 PH, Chrom-Vanadium-Stahl 31 Cr-V 3 (1.2208), matt verchromt, poliert
3077 00 02	2	52	52	10	9,20		
3077 00 03	3	52	55	10	9,20		
							For cross slot screws Philips Recess (DIN 3128), for manual drive, with black point tip, high grade tool steel, tip acc. to DIN 5260 PH, Chrome-Vanadium 31 Cr-V 3 (1.2208), chrome-plated, polished

Schraubendreher-Einsätze

Screwdriver Sockets



Art.-Nr. / No.							3078
	mm	mm	g	VE	EUR		
3078 00 01	4	45	48	10	7,95		Passend für Innensechskantschrauben (DIN 7426 / ISO 3109), für Handbetätigung, Klinge schwarz, aus legiertem Sonderstahl, Chrom-Vanadium-Stahl 31 Cr-V 3 (1.2208), matt verchromt, poliert
3078 00 02	5	45	48	10	7,95		
3078 00 03	6	45	50	10	7,95		
3078 00 04	7	45	55	10	7,95		
3078 00 05	8	45	55	10	7,95		
3078 00 06	10	45	58	10	7,95		
							For inside hexagon screws (DIN 7426 / ISO 3109), for manual drive, with black point tip, high grade tool steel, Chrome-Vanadium 31 Cr-V 3 (1.2208), chrome-plated, polished

Schraubendreher-Einsätze

Screwdriver Sockets



Steckschlüssel / Socket Sets

Schraubendreher-Einsätze Screwdriver Sockets

3/8"



3079

Passend für B&S-XZN - Schrauben, für Handbetätigung, Klinge schwarz, aus legiertem Sonderstahl, Chrom-Vanadium-Stahl 31 Cr-V 3 (1.2208), matt verchromt, poliert

For B&S-XZN screws, for manual drive, with black point tip, high grade tool steel, Chrome-Vanadium 31 Cr-V 3 (1.2208), chrome-plated, polished

Art.-Nr. / No.	mm	g	VE	EUR
3079 00 01	M5	45	45 10	10,75
3079 00 02	M6	45	48 10	10,75
3079 00 03	M8	45	50 10	10,75
3079 00 04	M10	45	55 10	11,75

Extra lang / long type				
3079 00 05	M8	93	70 10	11,75
3079 00 06	M10	93	82 10	13,25

Schraubendreher-Einsätze Screwdriver Sockets

3/8"



3080

Passend für RIBE-CV-Keilzahn - Schrauben, für Handbetätigung, Klinge schwarz, aus legiertem Sonderstahl, Chrom-Vanadium-Stahl 31 Cr-V 3 (1.2208), matt verchromt, poliert

For RIBE-CV screws, for manual drive, with black point tip, high grade tool steel, Chrome-Vanadium 31 Cr-V 3 (1.2208), chrome-plated, polished

Art.-Nr. / No.	mm	g	VE	EUR
3080 00 01	M5	45	45 10	10,75
3080 00 02	M6	45	48 10	10,75
3080 00 03	M8	45	50 10	10,75
3080 00 04	M10	45	55 10	11,75

Extra lang / long type				
3080 00 05	M8	93	70 10	11,75
3080 00 06	M10	93	82 10	13,25

Steckschlüssel-Einsätze, lang Hexagon Sockets, long type

3/8"



3081

Extra tief, Maße nach DIN 3124 / ISO 2725, passend für Außen-Sechskantschrauben, ideal für Muttern auf langen Gewindebolzen und für tief liegende Schrauben

Extra deep, according to DIN 3124 / ISO 2725, for outside hexagon bolts, perfect for nuts on long threaded bolts and for deep lying nuts

Art.-Nr. / No.	mm	mm	g	VE	EUR
3081 00 11	10	65	45 10	10,90	
3081 00 12	11	65	50 10	10,90	
3081 00 13	12	65	55 10	10,90	
3081 00 14	13	65	60 10	10,90	
3081 00 15	14	65	65 10	10,90	
3081 00 16	15	70	70 10	10,90	
3081 00 17	16	70	80 10	11,10	
3081 00 18	17	70	95 10	11,10	
3081 00 19	18	70	105 10	11,10	
3081 00 20	19	70	110 10	11,50	
3081 00 21	20	70	120 10	11,50	
3081 00 22	21	70	125 10	11,50	
3081 00 23	22	70	130 10	11,50	



Satz 3/8"-Steckschlüssel-Einsätze, lang, auf Klemmleiste, zum Befestigen an Werkstattwagen oder -wänden, mit 14 verschiebbaren Haltefedern

Set of 3/8"-sockets, long type, on socket rail, for fitting in tool trolleys or on tool bars, with 14 clips

3081 01 50	10-tlg. / pcs.		400	1	95,00
------------	----------------	--	-----	---	-------

Steckschlüssel-Einsätze Spark Plug Sockets

3/8"



3081

Passend für Zündkerzen, extra tief, mit Innensechskant, Chrom-Vanadium-Stahl 31 Cr-V 3 (1.2208), matt verchromt

For spark plugs, extra deep, with inside hexagon, Chrome-Vanadium 31 Cr-V 3 (1.2208), chrome-plated

Art.-Nr. / No.	mm	mm	g	VE	EUR
3081 00 04	16	5/8	80	160 10	13,75
3081 00 05	18	11/16	80	170 10	13,75
3081 00 02	20,8	13/16	80	185 10	13,75

Mit Magnet / with strong magnet					
3081 00 01	16	5/8	80	160 10	16,45
3081 00 03	20,8	13/16	80	185 10	16,45

Art.-Nr. / No.	E	mm	g	VE	EUR	
3090 00 01	8	30	45	10	6,50	<p>3090</p> <p>Passend für Außen-TORX-Schrauben, für Handbetätigung, Chrom-Vanadium-Stahl 31 Cr-V 3 (1.2208), matt verchromt</p> <p>For outside TORX-screws, for manual drive, Chrome-Vanadium 31 Cr-V 3 (1.2208), matt chrome-plated</p>
3090 00 02	10	30	45	10	6,50	
3090 00 03	11	30	45	10	6,50	
3090 00 04	12	30	50	10	6,50	
3090 00 05	14	30	50	10	6,50	

Schraubendreher-Einsätze
Screwdriver Sockets



Art.-Nr. / No.	TX	mm	g	VE	EUR	
3092 00 01	15	53	45	10	8,20	<p>3092</p> <p>Passend für Innen-TORX-Schrauben, für Handbetätigung, Chrom-Vanadium-Stahl 31 Cr-V 3 (1.2208), matt verchromt</p> <p>For inside TORX-screws, for manual drive, Chrome-Vanadium 31 Cr-V 3 (1.2208), matt chrome-plated</p>
3092 00 02	20	53	45	10	8,20	
3092 00 03	25	53	45	10	8,20	
3092 00 04	27	53	45	10	8,20	
3092 00 05	30	53	50	10	8,50	
3092 00 06	40	53	50	10	8,50	
3092 00 07	45	53	50	10	8,50	

Schraubendreher-Einsätze
Screwdriver Sockets



Art.-Nr. / No.	TX	mm	g	VE	EUR	
3092 00 11	15	53	45	10	8,20	<p>3092/10</p> <p>Passend für Tamper-Resistant-TORX-Schrauben (Innen-TORX-Schrauben mit Zapfenführung), für Handbetätigung, Chrom-Vanadium-Stahl 31 Cr-V 3 (1.2208), matt verchromt</p> <p>For Tamper resistant TORX screws (inside TORX screws with pin), for manual drive, Chrome-Vanadium 31 Cr-V 3 (1.2208), chrome-plated</p>
3092 00 12	20	53	45	10	8,20	
3092 00 13	25	53	45	10	8,20	
3092 00 14	27	53	45	10	8,20	
3092 00 15	30	53	50	10	8,50	
3092 00 16	40	53	50	10	8,50	
3092 00 17	45	53	50	10	8,50	

Schraubendreher-Einsätze
Screwdriver Sockets



Art.-Nr. / No.	mm	mm	g	VE	EUR	
3093 01 00	10	35	37	10	5,95	<p>3093</p> <p>Für Überwurfmutter und Rohrverschraubungen, Chrom-Vanadium-Stahl 31 Cr-V 3 (1.2208), matt verchromt</p> <p>For union nuts and pipe connections, Chrome-Vanadium 31 Cr-V 3 (1.2208), matt chrome-plated</p>
3093 01 10	11	35	37	10	5,95	
3093 01 20	12	35	37	10	5,95	
3093 01 30	13	35	37	10	5,95	
3093 01 40	14	38	46	10	5,95	
3093 01 50	15	38	46	10	6,65	
3093 01 60	16	38	46	10	6,65	
3093 01 70	17	43	62	10	6,65	
3093 01 80	18	43	62	5	6,65	
3093 01 90	19	43	64	5	6,65	
3093 00 01	10-tlg. / pcs.		400	1	32,00	<p>Satz auf Klemmleiste / Set 10-19mm</p>

Krähen-Fuß-Schlüssel
Crow Foot Spanners

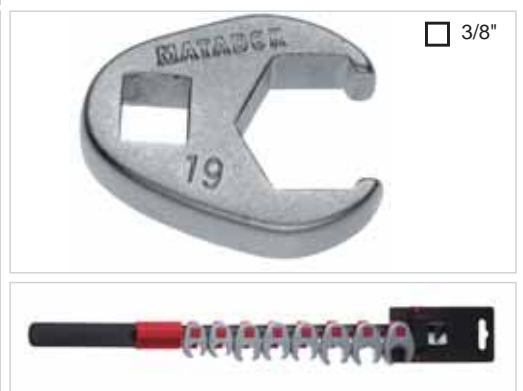

Steckschlüssel
Socket Sets

Steckschlüssel / Socket Sets

Glühkerzen-Einsätze Glow Plug Sockets

3/8"



3096

Zum Einsetzen und Lösen der Glühkerzen, mit Universalgelenk, insbesondere bei CommonRail-Motoren, z.B. für VW-AUDI Dieseldirekteinspritzer TDi und Mercedes Benz CDI, Chrom-Vanadium-Stahl 31 Cr-V 3 (1.2208), matt verchromt

For Glow Plugs, with universal joint, for VW-AUDI diesel direct injection engines TDi and Mercedes Benz CDI, Chrome-Vanadium 31 Cr-V 3 (1.2208), chrome-plated

Art.-Nr. / No.	mm	mm	g	VE	EUR
3096 00 01	8	89	65	1	29,90
3096 00 02	9	89	65	1	29,90
3096 00 03	10	70	70	1	29,90
3096 00 04	12	70	70	1	29,90
3096 00 05	9	50	25	1	21,50

MTS-Satz Glühkerzen-Einsätze MTS Set of Glow Plug Sockets

3/8"



3096 ModuFlex S

5-tlg., mit Einsätzen in 8, 9, 10, 12mm sowie speziellem, seitlich geschlitztem Einsatz zum Einsetzen und Lösen der Glühkerze bei montiertem Kontaktkabel, insbesondere bei CommonRail-Motoren; mit ModuFlex-System, d.h. Einlage in blau / schwarz, entnehmbar für Werkstattwagen, Werkbänke usw.

5-pcs., with Glow Plug Sockets 8, 9, 10, 12mm and special 9mm socket for Common Rail Diesel Engines; with ModuFlex-System (two-coloured hard foam module "see what is missing"), fits into workshop trolleys and benches, in black plastic case

Art.-Nr. / No.	g	VE	EUR
3096 60 10 5-tlg. / pcs.	300	1	115,00

Inhalt / contents:
8, 9, 10, 12mm
9x50mm



Glühkerzen-Einsätze / Glow Plug Sockets

Anwendung / Application:

- 8mm: Mercedes-Benz, Smart, VW, Fiat, Opel
- 9mm: Fiat 1,3 L Multijet-Motoren / Engines
- 10mm: VW / Audi TDi-Motoren / Engines, Mercedes-Benz CDI, Smart, Skoda
- 12mm: Mercedes-Benz 201 / 202, Vierventilmotoren / 4 valves engines Opel, BMW, Ford
- 9mm: 2.2L CommonRail Diesel-Motoren, z.B. CommonRail engines, e.g. Fiat, Lancia, Peugeot, Citroen

3/8"-Satz, 22-tlg. / 19-tlg. 3/8" Socket Set, 22 pcs. / 19 pcs.

3/8"



3115

Satz mit den gängigsten 3/8"-Steckschlüssel-einsätzen und -Werkzeugen, mit ABS-Einlage, im stabilen Metallkasten

Tool Set with the most popular 3/8" sockets and tools, with ABS-module, in metal case

Art.-Nr. / No.	g	VE	EUR
3115 00 03	2400	1	89,00
3061			
3064	200mm		
3065	125mm		
3066	250mm		
3068			
3075	6; 7; 8; 9; 10; 11; 12; 13; 14; 15; 16; 17; 18; 19; 20; 21; 22mm		
3115 00 01	2400	1	89,00
3061			
3115 00 04	2400	1	93,00
3061	Feinverzahnt / 72T		
3115 00 02	2400	1	93,00
3061	Feinverzahnt / 72T		

Art.-Nr. / No.	g	VE	EUR	Art.-Nr. / No.	g	VE	EUR
3115 60 02	2200	1	90,00	3115 61 01	2200	1	90,00
3061				3061			
3064		200mm		3064		200mm	
3065		125mm		3065		125mm	
3066		250mm		3066		250mm	
3068				3068			
3075		6; 7; 8; 9; 10; 11; 12; 13; 14; 15; 16; 17; 18; 19; 20; 21; 22mm		3075		1/4; 5/16; 11/32; 3/8; 7/16; 1/2; 9/16; 19/32; 5/8; 11/16; 3/4; 25/32; 13/16; 7/8" AF	
3115 60 01	2200	1	90,00	3115 61 04	2200	1	93,00
3061				3061		Feinverzahnt / 72T	
3115 60 03	2200	1	93,00	AF nur in Zwölfkant / AF only 12-pt.			
3061		Feinverzahnt / 72T					
3115 60 04	2200	1	93,00				
3061		Feinverzahnt / 72T					

3115

3/8"-Satz, 22-tlg. / 19-tlg. 38"-Socket Set, 22 pcs. / 19 pcs.

Satz mit den gängigsten Steckschlüsseinsätzen, mit ModuFlex-System, Größe M, d.h. Einlage in blau / schwarz, entnehmbar für Werkstattwagen, Werkbänke usw., im stabilen Kunststoffkoffer

Tool Set with the most popular 3/8" sockets, with ModuFlex-System (two-coloured hard foam module "see what is missing"), size M, fits into workshop trolleys and benches; in plastic case

ModuFlex M



Art.-Nr. / No.	g	VE	EUR	Art.-Nr. / No.	g	VE	EUR
3125 00 02	2800	1	118,00	3125 01 01	2800	1	118,00
3061				3061			
3064		200mm		3064		200mm	
3065		75, 125, 250mm		3065		75, 125, 250mm	
3068				3068			
3075		6; 7; 8; 9; 10; 11; 12; 13; 14; 15; 16; 17; 18; 19; 21; 22mm		3075		1/4; 5/16; 11/32; 3/8; 7/16; 1/2; 9/16; 19/32; 5/8; 11/16; 3/4; 25/32; 13/16; 7/8" AF	
3076		7; 8; 9mm		3076		7; 8; 9mm	
3077		PH 1; 2; 3		3077		PH 1; 2; 3	
3078		4; 5; 6; 8 x 60mm		3078		4; 5; 6; 8 x 60mm	
3125 00 01	2800	1	118,00	3125 01 04	2800	1	121,00
3061				3061		Feinverzahnt / 72T	
3125 00 03	2800	1	121,00	AF nur in Zwölfkant / AF only 12-pt.			
3061		Feinverzahnt / 72T					
3125 00 04	2800	1	121,00				
3061		Feinverzahnt / 72T					

3125

3/8"-Satz TORX, 31-tlg / 28-tlg. 38"-Socket Set TORX, 31 pcs / 28 pcs

Mit TORX-Steckschlüsseinsätzen für Innen- und Außen-TORX-Schrauben, mit ModuFlex-System Größe M, entnehmbar für Werkstattwagen, Chrom-Vanadium-Stahl 31 Cr-V 3 (1.2208), matt verchromt, im stabilen Kunststoffkoffer

With TORX-sockets for inside and outside screws, with ModuFlex-System, size M, fits into workshop trolleys; Chrome-Vanadium 31 Cr-V 3 (1.2208), chrome-plated, in plastic case

ModuFlex M



Art.-Nr. / No.	g	VE	EUR	Art.-Nr. / No.	g	VE	EUR
7052 60 02	27-tlg./pcs.	350	1	79,00			
2062		1/4"-Mini-Knarre / 72T-Mini ratchet					
3061		3/8"-Feinverzahnte Knarre / 72T ratchet					
7025		1/4" - 1/4"; 3/8" - 5/16"					
7029		1/4": TX 9, 15, 25, 30					
7026		1/4": M 4, 5					
7036		5/16": M 6, 8, 10, 12, 14					
7033		5/16": M 8, 10, 12, 14, 16 (100MM)					

7052

1/4"-3/8"-5-Stern / XZN / RIBE-Bits 1/4"-3/8"-5-Star / XZN / RIBE-Bits

Spezial-Satz für den Kfz-Bereich, mit feinverzahnter 1/4"-Mini-Umschaltknarre für engste Zwischenräume (Einstecktiefe mit Bit nur 25mm) und feinverzahnter 3/8"-Umschaltknarre, mit den wichtigsten Spezial-Bitsen und Adaptern (XZN, RIBE, 5-Stern), mit ModuFlex-System, Größe S, entnehmbar für Werkstattwagen, im stabilen Kunststoffkoffer

Special set for car maintenance, with 72T mini reversible ratchet for narrow spaces (insertion depth only 25mm) and 3/8" 72T-ratchet, includes all major special bits for car repair (XZN, RIBE, 5-star), with ModuFlex-System, size S, fits into workshop trolleys, in plastic case

ModuFlex S



Steckschlüssel / Socket Sets

Umschaltknarre Reversible Ratchet with Safety Lock

1/2"



4060

Nach DIN 3122 D / ISO 3315, sehr solide Verarbeitung, 32 Zähne für hohe Drehmomentwerte, ergonomischer Griff, Chrom-Vanadium-Stahl 31 Cr-V 3 (1.2208), matt verchromt

According to DIN 3122 D / ISO 3315, ratchet wheel with 32 teeth for high torque, ergonomic handle, Chrome-Vanadium 31 Cr-V 3 (1.2208), chrome-plated

Art.-Nr. / No.	mm	g	VE	EUR
4060 00 01	270	580	10	52,00
4060 00 10	Reparatursatz Repair Kit	135	1	25,00

Umschaltknarre mit Sicherheitsv. Reversible Ratchet with Safety Lock

1/2"



4061

Nach DIN 3122 D / ISO 3315, mit Sicherheitsverbindung (Einsätze werden fixiert und können nicht selbständig herausfallen; Freigabe mit einer Hand nach Drücken des Löseknopfes); Chrom-Vanadium-Stahl 31 Cr-V 3 (1.2208), matt verchromt

According to DIN 3122 D / ISO 3315, with safety lock, sockets can only be removed by pushing the safety button; Chrome-Vanadium 31 Cr-V 3 (1.2208), chrome-plated

Art.-Nr. / No.	mm	g	VE	EUR
4061 00 01	270	580	10	56,00
4061 00 10	Reparatursatz Repair Kit		1	25,00



Umschaltknarre, feinverzahnt Reversible Ratchet, 72-T

1/2"

72T



4061/3

Feinverzahnt, trotzdem extrem hohe Drehmomentwerte (über 700Nm = 30% über DIN!); mit Sicherheitsverbindung (Einsätze werden fixiert und können nicht selbständig herausfallen; Freigabe mit einer Hand nach Drücken des Löseknopfes); Chrom-Vanadium-Stahl 31 Cr-V 3 (1.2208), matt verchromt

72T, very high torque (more than 700Nm = 30% above DIN!), with safety lock, sockets can only be removed by pushing the safety button; Chrome-Vanadium 31 Cr-V 3 (1.2208), chrome-plated

Art.-Nr. / No.	mm	g	VE	EUR
4061 00 03	270	550	10	59,00
4061 00 13	Reparatursatz Repair Kit		1	25,00



Durchsteckknarre Ratchet, Push-Thru Type

1/2"



4062

Nach DIN 3122 C / ISO 3315, ergonomischer Griff, Chrom-Vanadium-Stahl 31 Cr-V 3 (1.2208), matt verchromt

According to DIN 3122 C / ISO 3315, ergonomic handle, Chrome-Vanadium 31 Cr-V 3 (1.2208), chrome-plated

Art.-Nr. / No.	mm	g	VE	EUR
4062 00 01	275 kpl. / compl.	450	10	26,90

Verbindungsvierkant, DIN 3122 / ISO 3315
Square Coupler

4062 00 02		35	44 10	4,80
------------	--	----	-------	------

Art.-Nr. / No.	↔ mm	⚖ g	📦 VE	EUR	4061/20
4061 00 20	220-570	2200	1	65,00	<p>Nach DIN 3122 D / ISO 3315, mit Sicherheitsverbindung, verlängerbar in drei Stufen: 220mm - 360mm und 570mm; besonders geeignet für Nfz und Industrieanwendungen, Chrom-Vanadium-Stahl 31 Cr-V 3 (1.2208), matt verchromt, 5-tlg. Satz in Karton</p> <p>According to DIN 3122 D / ISO 3315, with safety lock, extendable in three steps: 220mm mini ratchet for narrow spaces, 360mm standard type and 570mm mega ratchet; 36 teeth, 600Nm guaranteed, Chrome-Vanadium 31 Cr-V 3 (1.2208), chrome-plated, 5-pcs. set in cardboard box</p>
4061 00 21	Reparatursatz Repair Kit	135	1	25,00	

Verlängerbare Umschaltknarre

Extended Reversible Ratchet

 1/2"

600Nm!

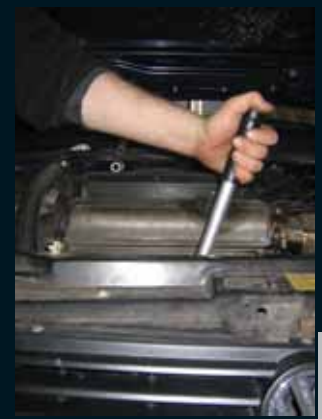

Art.-Nr. / No.	↔ mm	⚖ g	📦 VE	EUR	ModuFlex M 4061/20
4061 60 20	220-570	2400	1	75,00	<p>8-tlg. Satz zusammen mit Kardangelenke sowie Adaptern (1/2" auf 3/8" und 3/4"), mit ModuFlex-System, Größe M, d.h. Einlage in blau / schwarz, entnehmbar für Werkstattwagen, Werkbänke usw., im stabilen Kunststoffkoffer</p> <p>8-pcs. Tool Set with universal joint and adapters (1/2" - 3/8" and 3/4"), with ModuFlex-System (two-coloured hard foam module "see what is missing"), size M, fits into workshop trolleys and benches; in black plastic case</p>

1/2"-Umschaltknarrensatz "3in1"

1/2"-Ratchet Set "3in1"

 1/2"

Steckschlüssel / Socket Sets

Gleitgriff Sliding T-Handle

1/2"



4064

Nach DIN 3122 A / ISO 3315, Chrom-Vanadium-Stahl 31 Cr-V 3 (1.2208), matt verchromt

According to DIN 3122 A / ISO 3315, Chrome-Vanadium 31 Cr-V 3 (1.2208), chrome-plated

Art.-Nr. / No.

mm

g VE

EUR

4064 00 01

300

380 10 13,90

Verlängerungen Extensions

1/2"



4065 / 4066

Nach DIN 3123 B / ISO 3316, Chrom-Vanadium-Stahl 31 Cr-V 3 (1.2208), matt verchromt

According to DIN 3123 B / ISO 3316, Chrome-Vanadium 31 Cr-V 3 (1.2208), chrome-plated

Art.-Nr. / No.

mm

"

g VE

EUR

4065 00 01

75

3

120 10 7,90

4065 00 02

125

5

190 10 8,50

4066 00 01

250

10

360 10 11,50

Schwenkbare Verlängerungen Flexible Extensions

1/2"



1/2"



4065 / 4066

Mit Schwenkwinkel 5° nach jeder Seite, für engste Zwischenräume, nach DIN 3123 B / ISO 3316, Chrom-Vanadium-Stahl 31 Cr-V 3, matt verchromt

With 5° angular movement to each side, according to DIN 3123 B / ISO 3316, Chrome-Vanadium 1.2208, chrome-plated

Art.-Nr. / No.

mm

"

g VE

EUR

4065 00 12

125

5

190 10 11,20

4066 00 25

250

10

360 10 15,50



Verriegelbare Verlängerungen Locking Type Extensions

1/2"



4065

Verhindert versehentliches Herunterfallen von Steckschlüssel-Einsätzen an schwer zugänglichen Stellen, einfache und schnelle Freigabe des aufgesteckten Werkzeuges durch Zurückziehen des gerändelten Ringes, Oberfläche verchromt, Chrom-Vanadium-Stahl 31 Cr-V 3 (1.2208), matt verchromt

Avoids the accidental dropping of sockets during works in narrow places, easy and quick release of the socket by push-back of the knurled ring, Chrome-Vanadium 31 Cr-V 3 (1.2208), chrome-plated

Art.-Nr. / No.

mm

"

g VE

EUR

4065 10 12

125

5

140 10 12,50

4065 10 25

250

10

10 10 16,50

Art.-Nr. / No.	mm	"	g	VE	EUR	
4067 00 01	300	12	630	10	25,00	4067

Ideal für Arbeiten im Motorenraum, an der Ölwanne, für Generatorhalter, Kühlmittelpumpe usw., mit 1/2"-Kardangeln mit Innenvierkant und 1/2"-Außenvierkant am T-Griff; Chrom-Vanadium-Stahl 31 Cr-V 3 (1.2208), matt verchromt

 Perfect for all work in narrow spaces, e.g. for the oil pan, for generator holder, cooling pump, fuel pump etc., with 1/2" universal joint with inner square and 1/2" outer square on T-handle; Chrome-Vanadium 31 Cr-V 3 (1.2208), chrome-plated

T-Griff mit 1/2"-Aufnahme
T-Handle with 1/2"-coupler

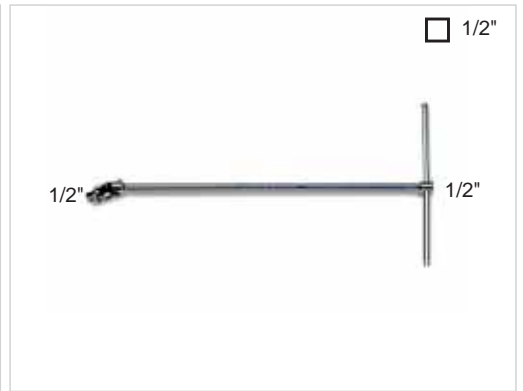

Art.-Nr. / No.	mm	g	VE	EUR	
4068 00 01	75	570	10	19,95	4068

Nach DIN 3123 C / ISO 3316, Chrom-Vanadium-Stahl 31 Cr-V 3 (1.2208), matt verchromt

 According to DIN 3123 C / ISO 3316, Chrome-Vanadium 31 Cr-V 3 (1.2208), chrome-plated

Kardangeln
Universal Joint



Art.-Nr. / No.	mm	g	VE	EUR	
4070 00 01	350	570	5	19,50	4070

Nach DIN 3122 B / ISO 3315, mit 1/2"-Aufnahme, Chrom-Vanadium-Stahl 31 Cr-V 3 (1.2208), matt verchromt

 According to DIN 3123 B / ISO 3316, with 1/2" drive, Chrome-Vanadium 31 Cr-V 3 (1.2208), chrome-plated

Kurbel
Speed Brace



Art.-Nr. / No.	mm	"	g	VE	EUR	
4072 00 02	390	15	640	5	34,50	4072

Nach DIN 3122 F / ISO 3315, mit 1/2"-Aufnahme, Chrom-Vanadium-Stahl 31 Cr-V 3 (1.2208), matt verchromt

 According to DIN 3123 F / ISO 3316, with 1/2" drive, Chrome-Vanadium 31 Cr-V 3 (1.2208), chrome-plated

Gelenkgriff
Swivel Handle



Steckschlüssel
Socket Sets

Steckschlüssel / Socket Sets

Verbindungsstücke Socket Converters



4082 / 4083

DIN 3123 A / ISO 3316, Chrom-Vanadium-Stahl
31 Cr-V 3 (1.2208), matt verchromt

According to DIN 3123 A / ISO 3316, Chrome-Vanadium 31 Cr-V 3 (1.2208), chrome-plated

Art.-Nr. / No.	mm	mm	g	VE	EUR
4082 00 01	1/2"	3/4"	110	10	9,50
4083 00 01	3/4"	1/2"	125	10	12,50

Verbindungsstücke für Bits Bit Converters



4084

Zum Einsetzen von 1/4"-Bits, nach DIN 3123 A / ISO 3316, mit Innen-4-kant- und Innen-6-kant-Aufnahme, mit Haltekugel für Bits, Chrom-Vanadium-Stahl 31 Cr-V 3 (1.2208), matt verchromt

For 1/4"-bits, according to DIN 3123 A / ISO 3316, with inside square and inside hexagon drive, with clamping ball for bits, Chrome-Vanadium 31 Cr-V 3 (1.2208), chrome-plated

Art.-Nr. / No.	mm	mm	g	VE	EUR
4084 00 01	1/2"	1/4"	45	5	8,60
4084 00 02	1/2"	5/16"	60	5	9,65
4084 00 03	1/2"	10mm	80	5	9,65

Steckschlüssel-Einsätze Sockets





4075

Passend für Außensechskant-Schrauben, mit Zwölfkant-Profil, nach DIN 3120 / ISO 1174, für Handbetätigung, Chrom-Vanadium-Stahl, 31 Cr-V 3 (1.2208), matt verchromt, poliert

For outside hexagon screws, 12-pt., 1/2"-square drive acc. to DIN 3120 / ISO 1174, for manual drive, Chrome-Vanadium 31 Cr-V 3 (1.2208), matt chrome-plated, polished

Art.-Nr. / No.	mm	mm	g	VE	EUR	Art.-Nr. / No.	mm	mm	g	VE	EUR
4075 00 01	10	40	60	10	4,90	4075 01 01	3/8	40	55	10	4,90
4075 00 02	11	40	60	10	4,90	4075 01 02	7/16	40	55	10	4,90
4075 00 03	12	40	60	10	4,90	4075 01 03	15/32	40	55	10	4,90
4075 00 04	13	40	60	10	4,90	4075 01 04	1/2	40	55	10	4,90
4075 00 05	14	40	60	10	4,90	4075 01 05	9/16	40	55	10	4,90
4075 00 06	15	40	60	10	4,90	4075 01 06	19/32	40	60	10	4,90
4075 00 07	16	40	60	10	4,90	4075 01 07	5/8	40	60	10	4,90
4075 00 08	17	40	60	10	5,40	4075 01 08	21/32	40	60	10	5,40
4075 00 09	18	40	60	10	5,40	4075 01 09	11/16	40	65	10	5,40
4075 00 10	19	40	70	10	5,40	4075 01 10	3/4	40	70	10	5,40
4075 00 11	20	40	75	10	5,40	4075 01 11	25/32	40	80	10	5,40
4075 00 12	21	40	85	10	5,40	4075 01 12	13/16	40	85	10	5,40
4075 00 13	22	40	90	10	6,50	4075 01 13	7/8	40	100	10	5,40
4075 00 14	23	40	100	10	6,50	4075 01 14	15/16	40	110	5	6,50
4075 00 15	24	42	110	10	6,80	4075 01 15	31/32	40	115	5	6,50
4075 00 16	25	42	110	5	6,80	4075 01 16	1	42	130	5	6,80
4075 00 17	26	42	130	5	6,80	4075 01 17	1.1/16	44	135	5	8,20
4075 00 18	27	44	130	5	8,20	4075 01 18	1.1/8	44	160	5	8,20
4075 00 19	28	44	140	5	8,20	4075 01 19	1.3/16	44	160	5	8,20
4075 00 20	29	44	140	5	8,20	4075 01 20	1.1/4	46	175	5	8,20
4075 00 21	30	46	160	5	8,20						
4075 00 22	32	46	175	5	8,20						



Art.-Nr. / No.	mm	mm	g	VE	EUR	4075
4075 00 31	8	40	45	10	4,90	<p>Passend für Außensechskant-Schrauben, mit Sechskant-Profil, nach DIN 3120 / ISO 1174, für Handbetätigung, Chrom-Vanadium-Stahl, 31 Cr-V 3 (1.2208), matt verchromt, poliert</p> <p>For outside hexagon screws, 6-pt., 1/2"-square drive acc. to DIN 3120 / ISO 1174, for manual drive, Chrome-Vanadium 31 Cr-V 3 (1.2208), matt chrome-plated, polished</p> 
4075 00 32	9	40	55	10	4,90	
4075 00 33	10	40	55	10	4,90	
4075 00 34	11	40	60	10	4,90	
4075 00 35	12	40	60	10	4,90	
4075 00 36	13	40	60	10	4,90	
4075 00 37	14	40	60	10	4,90	
4075 00 38	15	40	60	10	4,90	
4075 00 39	16	40	60	10	4,90	
4075 00 40	17	40	60	10	5,40	
4075 00 41	18	40	60	10	5,40	
4075 00 42	19	40	70	10	5,40	
4075 00 43	20	40	75	10	5,40	
4075 00 44	21	40	85	10	5,40	
4075 00 45	22	40	90	10	6,50	
4075 00 46	23	40	100	10	6,50	
4075 00 47	24	42	110	10	6,80	
4075 00 48	25	42	110	10	6,80	
4075 00 49	26	42	130	5	6,80	
4075 00 50	27	44	130	5	8,20	
4075 00 51	28	44	140	5	8,20	
4075 00 52	29	44	140	5	8,20	
4075 00 53	30	46	160	5	8,20	
4075 00 54	32	46	175	5	8,20	
4075 00 55	36	46	240	5	8,20	
4075 01 50	14-tlg. / pcs. 10-19; 21; 22; 24; 27mm		1140	1	45,00	<p>Satz 1/2"-Steckschlüssel-Einsätze auf Klemmleiste, zum Befestigen an Werkstattwagen oder -wänden, mit 14 verschiebbaren Haltefedern</p> <p>Set of 1/2"-sockets on socket rail, for fitting in tool trolleys or on tool bars, with 14 socket clips</p> 
4075 01 51	14-tlg. / pcs. 10-19; 21; 22; 24; 27mm		1140	1	45,00	
4075 01 60	14-tlg. / pcs. 3/8-3/4; 7/8; 1"; 1.1/16"; 1.1/8"; 1.1/4" AF		1200	1	45,00	

Steckschlüssel-Einsätze Sockets



Art.-Nr. / No.	mm	mm	g	VE	EUR	4076
4076 00 02	1,2 x 8	65	62	10	9,50	<p>Passend für Schlitzschrauben, DIN 3127 / ISO 2351, für Handbetätigung, Klinge schwarz, aus legiertem Sonderstahl, Klinge nach DIN 5264 / ISO 2380-1, Chrom-Vanadium-Stahl 31 Cr-V 3 (1.2208), matt verchromt, poliert</p> <p>For slotted screws, DIN 3120 / ISO 1174, for manual drive, with black point tip, high grade tool steel, tip acc. to DIN 5264 / ISO 2380-1, Chrome-Vanadium 31 Cr-V 3 (1.2208), chrome-plated, polished</p>
4076 00 03	1,6 x 10	65	62	10	9,50	
4076 00 04	2,0 x 12	65	62	10	9,80	
4076 00 05	2,5 x 14	65	62	10	9,80	

Schraubendreher-Einsätze Screwdriver Sockets



Art.-Nr. / No.	PH	mm	g	VE	EUR	4077
4077 00 01	2	60	65	10	9,50	<p>Passend für Kreuzschlitzschrauben Philips-Recess (DIN 3128), für Handbetätigung, Klinge schwarz, aus legiertem Sonderstahl, Klinge nach DIN 5260 PH, Chrom-Vanadium-Stahl 31 Cr-V 3 (1.2208), matt verchromt, poliert</p> <p>For cross slot screws Philips Recess (DIN 3128), for manual drive, with black point tip, high grade tool steel, tip acc. to DIN 5260 PH, Chrome-Vanadium 31 Cr-V 3 (1.2208), chrome-plated, polished</p>
4077 00 02	3	60	65	10	9,50	
4077 00 03	4	60	65	10	9,50	

Schraubendreher-Einsätze Screwdriver Sockets



Steckschlüssel
Socket Sets

Steckschlüssel / Socket Sets

Schraubendreher-Einsätze Screwdriver Sockets

1/2"



4078

Passend für Innensechskantschrauben (DIN 7426 / ISO 3109), für Handbetätigung, Klinge schwarz, aus legiertem Sonderstahl, Chrom-Vanadium-Stahl 31, Cr-V 3 (1.2208), matt verchromt, poliert

For inside hexagon screws (DIN 7426 / ISO 3109), for manual drive, with black point tip, high grade tool steel, Chrome-Vanadium 31 Cr-V 3 (1.2208), chrome-plated, polished

Art.-Nr. / No.	mm	mm	g	VE	EUR
4078 00 01	4	60	54	10	6,50
4078 00 02	5	60	55	10	6,50
4078 00 05	6	60	56	10	6,50
4078 00 25	7	60	70	10	6,80
4078 00 11	8	60	58	10	6,80
4078 00 15	10	60	60	10	6,80
4078 00 17	12	60	85	10	6,80
4078 00 23	14	42	85	10	7,80
4078 00 18	14	60	100	10	7,80
4078 00 24	17	42	95	10	7,80
4078 00 19	17	60	110	10	7,80
4078 00 20	19	60	115	10	8,20

Art.-Nr. / No.	mm	mm	g	VE	EUR
4078 01 30	3/16	60	70	10	10,50
4078 01 31	7/32	60	70	10	10,50
4078 01 32	1/4	60	70	10	10,50
4078 01 33	5/16	60	80	10	10,50
4078 01 34	3/8	60	85	10	10,50
4078 01 35	7/16	60	125	10	10,50
4078 01 36	1/2	60	125	10	10,50
4078 01 37	9/16	60	130	10	10,50

1/2"



9-tlg. Satz im stabilen Metallkasten, passend für Innensechskantschrauben (DIN 7426 / ISO 3109), für Handbetätigung, Klinge schwarz, aus legiertem Sonderstahl, Chrom-Vanadium-Stahl 31, Cr-V 3 (1.2208), matt verchromt, poliert

9 pcs. set in metal case, for inside hexagon screws (DIN 7426 / ISO 3109), for manual drive, with black point tip, high grade tool steel, Chrome-Vanadium 31 Cr-V 3 (1.2208), chrome-plated, polished

Art.-Nr. / No.	g	VE	EUR
4078 00 40	1200	1	68,00

Inhalt / contents:
5, 6, 7, 8, 10, 12, 14, 17, 19 x 60mm

Schraubendreher-Einsätze, lang Screwdriver Sockets, long type

1/2"



4078

Extra lang, passend für Innensechskantschrauben (DIN 7426 / ISO 3109), für Handbetätigung, Klinge schwarz, aus legiertem Sonderstahl, Chrom-Vanadium-Stahl 31, Cr-V 3 (1.2208), matt verchromt, poliert

Long type, for inside hexagon screws (DIN 7426 / ISO 3109), for manual drive, with black point tip, high grade tool steel, Chrome-Vanadium 31 Cr-V 3 (1.2208), chrome-plated, polished

Art.-Nr. / No.	mm	mm	g	VE	EUR
4078 00 03	5	110	75	10	7,90
4078 00 04	5 x 8	180	100	10	10,50
4078 00 06	6	70	70	10	7,90
4078 00 07	6	110	80	10	8,30
4078 00 08	6	200	100	10	11,30
4078 00 09	7	100	75	10	8,30
4078 00 10	7	150	100	10	8,60
4078 00 12	8	80	75	10	7,90
4078 00 13	8	110	100	10	8,30
4078 00 14	8	200	130	10	12,90
4078 00 21	10	80	75	10	7,90
4078 00 16	10	140	95	10	8,50
4078 00 22	10	200	110	10	13,50
4078 00 28	13	70	135	10	7,90

Schraubendreher-Einsätze Screwdriver Sockets

1/2"



4079

Passend für B&S-XZN - Schrauben, für Handbetätigung, Klinge schwarz, aus legiertem Sonderstahl, Chrom-Vanadium-Stahl 31 Cr-V 3 (1.2208), matt verchromt, poliert

For B&S-XZN screws, for manual drive, with black point tip, high grade tool steel, Chrome-Vanadium 31 Cr-V 3 (1.2208), chrome-plated, polished

Art.-Nr. / No.	mm	g	VE	EUR	
4079 00 01	M5	60	55	10	8,80
4079 00 03	M6	60	56	10	8,80
4079 00 05	M8	60	58	10	8,80
4079 00 07	M10	60	62	10	9,20
4079 00 09	M12	60	65	10	10,50
4079 00 12	M14	60	70	10	13,20
4079 00 13	M16	60	75	10	13,50

Art.-Nr. / No.	mm	mm	g	VE	EUR	4079
4079 00 02	M5	200	130	10	13,50	<p>Extra lang, passend für B&S-XZN - Schrauben, für Handbetätigung, Klinge schwarz, aus legiertem Sonderstahl, Chrom-Vanadium-Stahl 31 Cr-V 3 (1.2208), matt verchromt, poliert</p> <p>Long type, for B&S-XZN screws, for manual drive, with black point tip, high grade tool steel, Chrome-Vanadium 31 Cr-V 3 (1.2208), chrome-plated, polished</p>
4079 00 04	M6	100	88	10	9,50	
4079 00 06	M8	100	90	10	9,70	
4079 00 08	M10	100	108	10	11,50	
4079 00 14	M10	140	140	10	12,50	
4079 00 10	M12	100	120	10	12,50	
4079 00 11	M12	140	156	10	13,50	

Schraubendreher-Einsätze, lang

Screwdriver Sockets, long type



Art.-Nr. / No.		g	VE	EUR	4079
4079 00 40	7-tlg. / pcs.	1200	1	45,00	<p>7-tlg. Satz im stabilen Metallkasten, passend für B&S-XZN - Schrauben, für Handbetätigung, Klinge schwarz, aus legiertem Sonderstahl, Chrom-Vanadium-Stahl 31 Cr-V 3 (1.2208), matt verchromt, poliert</p> <p>7 pcs. set in metal case, for B&S-XZN screws, for manual drive, with black point tip, high grade tool steel, Chrome-Vanadium 31 Cr-V 3 (1.2208), chrome-plated, polished</p>
<p>Inhalt / contents: M5, 6, 8, 10, 12 x 60, M8 x 100, M10 x 100 mm</p>					

Satz Schraubendreher-Einsätze

Screwdriver Socket Set



Art.-Nr. / No.	mm	mm	g	VE	EUR	4080
4080 00 01	M5	63	58	10	9,50	<p>Passend für RIBE-CV-Keilzahn - Schrauben, für Handbetätigung, Klinge schwarz, aus legiertem Sonderstahl, Chrom-Vanadium-Stahl 31 Cr-V 3 (1.2208), matt verchromt, poliert</p> <p>For RIBE-CV screws, for manual drive, with black point tip, high grade tool steel, Chrome-Vanadium 31 Cr-V 3 (1.2208), chrome-plated, polished</p>
4080 00 02	M6	63	59	10	9,50	
4080 00 03	M8	63	62	10	9,50	
4080 00 04	M10	63	65	10	10,20	
4080 00 05	M12	63	70	10	11,20	
4080 00 06	M14	63	75	10	12,40	
4080 00 07	M16	63	80	10	13,80	
4080 00 10	M5	140	90	10	11,80	
4080 00 11	M6	140	125	10	11,80	
4080 00 12	M8	140	126	10	12,50	
4080 00 13	M10	140	140	10	12,90	
4080 00 14	M12	140	156	10	14,80	
4080 00 15	M14	140	166	10	17,30	
4080 00 16	M16	140	178	10	17,90	

Schraubendreher-Einsätze

Screwdriver Sockets



Art.-Nr. / No.	mm	mm	g	VE	EUR	4081
4081 00 10	10	80	95	5	12,30	<p>Passend für Außensechskant-Schrauben, lange Ausführung, mit Sechskant-Profil, nach DIN 3120 / ISO 1174, für Handbetätigung, Chrom-Vanadium-Stahl, 31 Cr-V 3 (1.2208), matt verchromt, poliert</p> <p>For outside hexagon screws, long type, 6-pt., 1/2"-square drive acc. to DIN 3120 / ISO 1174, for manual drive, Chrome-Vanadium 31 Cr-V 3 (1.2208), matt chrome-plated, polished</p>
4081 00 11	11	80	115	5	12,30	
4081 00 12	12	80	110	5	12,30	
4081 00 13	13	80	130	5	12,30	
4081 00 14	14	80	135	5	13,50	
4081 00 15	15	80	155	5	13,50	
4081 00 16	17	80	140	5	14,30	
4081 00 17	19	80	160	5	14,30	
4081 00 18	21	80	180	5	14,50	
4081 00 19	22	80	230	5	14,50	
4081 00 20	24	80	230	5	16,50	
4081 00 21	27	80	240	5	17,50	
4081 00 22	30	80	325	5	19,50	
4081 00 23	32	80	275	5	19,50	

Steckschlüssel-Einsätze, lang

Sockets, long type



Steckschlüssel
Socket Sets

Steckschlüssel / Socket Sets

Steckschlüssel-Einsätze Spark Plug Sockets



4081

Passend für Zündkerzen, extra tief, mit Innensechskant, Chrom-Vanadium-Stahl 31 Cr-V 3 (1.2208), matt verchromt

For spark plugs, extra deep, with inside hexagon, Chrome-Vanadium 31 Cr-V 3 (1.2208), chrome-plated

Art.-Nr. / No.	mm	"	mm	g	VE	EUR
----------------	----	---	----	---	----	-----

Mit Gummieinsatz / with rubber insert:

4081 00 01	16	5/8	65	100	10	13,50
4081 00 04	18	11/16	68	150	10	13,80
4081 00 03	20,8	13/16	68	160	10	14,50

Mit Magnet / with strong magnet

4081 00 07	16	5/8	65	100	10	16,90
4081 00 06	20,8	13/16	68	160	10	17,90

Schraubendreher-Einsätze Screwdriver Sockets



4090

Passend für Außen-TORX-Schrauben, für Handbetätigung, Chrom-Vanadium-Stahl 31 Cr-V 3 (1.2208), matt verchromt

For outside TORX-screws, for manual drive, Chrome-Vanadium 31 Cr-V 3 (1.2208), chrome-plated

Art.-Nr. / No.	E	mm	g	VE	EUR
----------------	---	----	---	----	-----

4090 00 01	10	40	60	10	7,60
4090 00 02	12	40	60	10	7,60
4090 00 03	14	40	70	10	8,20
4090 00 04	16	40	83	10	8,30
4090 00 05	18	40	87	10	8,30
4090 00 06	20	40	90	10	8,50
4090 00 07	24	40	95	10	9,80

1/4"-3/8"-1/2"-Außen-TORX 1/4"-3/8"-1/2" Outside TORX



4090 ModuFlex S

9-tlg. Satz Schraubendreher-Einsätze für Außen-TORX-Schrauben, für Handbetätigung, Chrom-Vanadium-Stahl 31 Cr-V 3 (1.2208), matt verchromt, mit ModuFlex-System, d.h. Einlage in blau / schwarz, entnehmbar für Werkstattwagen, Werkbänke usw., im stabilen Kunststoffkoffer

9 pcs. set for outside TORX-screws, for manual drive, Chrome-Vanadium 31 Cr-V 3 (1.2208), chrome-plated; with ModuFlex-System (two-coloured hard foam module "see what is missing"), fits into workshop trolleys and benches; in plastic case

Art.-Nr. / No.	g	VE	EUR
----------------	---	----	-----

4090 00 41	9-tlg. / pcs.	300	1	39,00
------------	---------------	-----	---	-------

Inhalt / contents:

1/4":	E4; 5; 6
3/8":	E 8; 10; 12
1/2":	E 14; 18; 20

Schraubendreher-Einsätze Screwdriver Sockets



4092



Passend für Innen-TORX-Schrauben, für Handbetätigung, Chrom-Vanadium-Stahl 31 Cr-V 3 (1.2208), matt verchromt

For inside TORX-screws, for manual drive, Chrome-Vanadium 31 Cr-V 3 (1.2208), chrome-plated

Extra lang / long type

Art.-Nr. / No.	TX	mm	g	VE	EUR
----------------	----	----	---	----	-----

4092 00 01	TX 20	60	80	10	11,00
4092 00 02	TX 25	60	80	10	11,00
4092 00 03	TX 27	60	80	10	11,00
4092 00 04	TX 30	60	85	10	11,00
4092 00 05	TX 40	60	85	10	12,00
4092 00 06	TX 45	60	85	10	12,00
4092 00 07	TX 50	60	100	10	12,00
4092 00 08	TX 55	60	110	10	14,50
4092 00 09	TX 60	60	120	10	14,50
4092 00 10	TX 45	140	150	10	15,20
4092 00 11	TX 55	140	210	10	15,20
4092 00 12	TX 70	110	200	10	12,00

Art.-Nr. / No.		 g	 VE	EUR	ModuFlex S 4092
4092 00 42	10-tlg. / pcs.	350	1	48,00	
Inhalt / contents					
1/4": TX 8; 10; 15					
3/8": TX 20; 25; 30					
1/2": TX 40; 50; 55; 60					
<p>10-tlg. Satz Schraubendreher-Einsätze für Innen-TORX-Schrauben, für Handbetätigung, Chrom-Vanadium-Stahl 31 Cr-V 3 (1.2208), matt verchromt, mit ModuFlex-System, d.h. Einlage in blau / schwarz, entnehmbar für Werkstattwagen, Werkbänke usw., im stabilen Kunststoffkoffer</p> <p>10 pcs. set for inside TORX-screws, for manual drive, Chrome-Vanadium 31 Cr-V 3 (1.2208), chrome-plated; with ModuFlex-System (two-coloured hard foam module "see what is missing"), fits into workshop trolleys and benches; in plastic case</p>					



1/4"-3/8"-1/2"-Innen-TORX
1/4"-3/8"-1/2" Inside TORX



Art.-Nr. / No.		 g	 VE	EUR	4092
4092 00 40	9-tlg. / pcs.	1100	1	59,00	
Inhalt / contents					
1/2": TX 20; 25; 27; 30; 40; 45; 50; 55; 60					
<p>9-tlg. Satz im stabilen Metallkasten, passend für Innen-TORX-Schrauben, für Handbetätigung, Chrom-Vanadium-Stahl 31 Cr-V 3 (1.2208), matt verchromt, poliert</p> <p>9 pcs. set in metal case, for inside TORX-screws, for manual drive, with black point tip, high grade tool steel, Chrome-Vanadium 31 Cr-V 3 (1.2208), chrome-plated, polished</p>					

Satz Schraubendreher-Einsätze
Screwdriver Socket Set



Art.-Nr. / No.	TX	mm	 g	 VE	EUR	4092/20
4092 00 21	TX 20	60	80	10	11,00	
4092 00 22	TX 25	60	80	10	11,00	
4092 00 23	TX 27	60	80	10	11,00	
4092 00 24	TX 30	60	85	10	11,00	
4092 00 25	TX 40	60	85	10	12,00	
4092 00 26	TX 45	60	85	10	12,00	
4092 00 27	TX 50	60	100	10	12,00	
4092 00 28	TX 55	60	110	10	14,50	
4092 00 29	TX 60	60	120	10	14,50	
<p>Passend für Tamper-Resistant-TORX-Schrauben (Innen-TORX-Schrauben mit Zapfenführung), für Handbetätigung, Chrom-Vanadium-Stahl 31 Cr-V 3 (1.2208), matt verchromt</p> <p>For Tamper resistant TORX screws (inside TORX screws with pin), for manual drive, Chrome-Vanadium 31 Cr-V 3 (1.2208), chrome-plated</p>						

Schraubendreher-Einsätze
Screwdriver Sockets



Art.-Nr. / No.		 g	 VE	EUR	4092/20
4092 20 40	9-tlg. / pcs.	1100	1	59,00	
Inhalt / contents					
1/2": TX 20; 25; 27; 30; 40; 45; 50; 55; 60					
<p>9-tlg. Satz im stabilen Metallkasten, passend für Tamper-Resistant-TORX-Schrauben (Innen-TORX-Schrauben mit Zapfenführung), für Handbetätigung, Chrom-Vanadium-Stahl 31 Cr-V 3 (1.2208), matt verchromt, poliert</p> <p>9 pcs. set in metal case, for Tamper resistant TORX screws (inside TORX screws with pin), for manual drive, with black point tip, high grade tool steel, Chrome-Vanadium 31 Cr-V 3 (1.2208), chrome-plated, polished</p>					

Satz Schraubendreher-Einsätze
Screwdriver Socket Set



Steckschlüssel / Socket Sets

1/2"-Basis-Satz, 17-tlg. 1/2" Basic Socket Set, 17 pcs.











1/2"  



4105

Basis-Satz mit den wichtigsten 1/2"-Steckschlüsseleinsätzen, mit 1/2"-Durchsteckknarre, Chrom-Vanadium-Stahl 31 Cr-V 3 (1.2208), matt verchromt, mit ABS-Einlage, im stabilen Metallkasten

Basic Tool Set with the most important 1/2" sockets and Push-Thru Type ratchet, Chrome-Vanadium 31 Cr-V 3 (1.2208), chrome-plated, with ABS-module, in metal case

Art.-Nr. / No.	g	VE	EUR	Art.-Nr. / No.	g	VE	EUR
4105 00 03	3080	1	85,00	4105 01 03	3080	1	85,00
4062				4062			
4064		300mm		4064		300mm	
4066		250mm		4066		250mm	
4068				4068			
4075		10; 11; 12; 13; 14; 15; 16; 17; 18; 19; 20; 21; 22mm		4075		3/8; 7/16; 15/32; 1/2; 9/16; 19/32; 5/8; 21/32; 11/16; 3/4; 25/32; 13/16; 7/8" AF	
4105 00 01	3080	1	87,00				
4062							

AF nur in Zwölfkant / AF only 12-pt.

1/2"-Satz, 20-tlg. / 18-tlg. 1/2" Socket Set, 20 pcs / 18 pcs

















1/2"  



4110

Satz mit den gängigsten 1/2"-Steckschlüsseleinsätzen und -Werkzeugen, Chrom-Vanadium-Stahl 31 Cr-V 3 (1.2208), matt verchromt, mit ABS-Einlage, im stabilen Metallkasten

Tool Set with the most popular 1/2" sockets and tools, Chrome-Vanadium 31 Cr-V 3 (1.2208), chrome-plated, with ABS-module, in metal case

Art.-Nr. / No.	g	VE	EUR	Art.-Nr. / No.	g	VE	EUR
4110 00 04	3600	1	94,00	4110 01 02	3600	1	94,00
4060				4060			
4064		300mm		4064		300mm	
4065		125mm, 250mm		4065		125mm, 250mm	
4068				4068			
4075		10; 11; 12; 13; 14; 15; 16; 17; 18; 19; 22; 24; 27; 30; 32mm		4075		3/8; 7/16; 15/32; 1/2; 9/16; 19/32; 21/32; 3/4; 7/8; 1; 1.1/16; 1.1/8; 1.1/4" AF	
4110 00 02	3600	1	94,00	4110 01 12	3600	1	97,00
4060				4061			
4110 00 14	3600	1	97,00	4110 01 22	3600	1	99,00
4061				4061		Feinverzahnt / 72T	
4110 00 12	3600	1	97,00				
4061							
4110 00 24	3600	1	99,00				
4061		Feinverzahnt / 72T					
4110 00 22	3600	1	99,00				
4061		Feinverzahnt / 72T					

AF nur in Zwölfkant / AF only 12-pt.

1/2"-Kfz-Satz, 19-tlg. 1/2" Socket Set for cars, 19 pcs.















1/2"  



4111

Kfz-Satz mit 1/2"-Steckschlüsseleinsätzen, auch für Zündkerzen, mit 1/2"-Umschaltknarre mit Sicherheitsverbindung und schwenkbarer Verlängerung, Chrom-Vanadium-Stahl 31 Cr-V 3 (1.2208), matt verchromt, mit ABS-Einlage, im stabilen Metallkasten

Tool Set with the most popular 1/2" sockets and tools, with 1/2" safety lock ratchet and flexible extension, Chrome-Vanadium 31 Cr-V 3 (1.2208), chrome-plated, with ABS-module, in metal case

Art.-Nr. / No.	g	VE	EUR	Art.-Nr. / No.	g	VE	EUR
4111 00 02	4600	1	97,00	4111 01 01	4600	1	97,00
4061				4061			
4064				4064			
4065		125mm schwenkbar / wobble		4065		125mm schwenkbar / wobble	
4066		250mm flexibel / flexible		4066		250mm flexibel / flexible	
4081		16; 20,8mm		4081		16; 20,8mm	
4075		10; 11; 12; 13; 14; 15; 17; 19; 22; 24; 27; 30; 32mm		4075		3/8; 7/16; 15/32; 1/2; 9/16; 19/32; 21/32; 3/4; 7/8; 1; 1.1/16; 1.1/8; 1.1/4" AF	
4111 00 01	4600	1	97,00	4111 01 21	4600	1	99,00
4061				4061		Feinverzahnt / 72T	
4111 00 22	4600	1	99,00				
4061		Feinverzahnt / 72T					
4111 00 21	4600	1	99,00				
4061		Feinverzahnt / 72T					

AF nur in Zwölfkant / AF only 12-pt.

Art.-Nr. / No.	g	VE	EUR	Art.-Nr. / No.	g	VE	EUR
4114 00 06	4400	1	105,00	4114 01 05	4400	1	105,00
4060				4060			
4064				4064			
4065		125, 250mm		4065		125, 250mm	
4068				4068			
4075		10;11;12;13;14;15;16;17;18;19;20;21;22;23;24;27;30;32mm		4075		3/8;7/16;1/2;9/16;19/32;5/8;11/16;3/4;25/32;13/16;7/8;15/16;31/32;1;1.1/16;1.1/8;1.3/16;1.1/4" AF	
4114 00 05	4400	1	105,00	4114 01 15	4400	1	108,00
4060				4061			
4114 00 16	4400	1	108,00	4114 01 25	4400	1	112,00
4061				4061		Feinverzahnt / 72T	
4114 00 15	4400	1	108,00				
4061							
4114 00 26	4400	1	112,00				
4061		Feinverzahnt / 72T					
4114 00 25	4400	1	112,00				
4061		Feinverzahnt / 72T					

4114

1/2"-Satz, 23-tlg. 1/2" Socket Set, 23 pcs.

Satz mit den gängigsten 1/2"-Steckschlüssel-einsätzen und -Werkzeugen, Chrom-Vanadium-Stahl 31 Cr-V 3 (1.2208), matt verchromt, mit ABS-Einlage, im stabilen Metallkasten

Tool Set with the most popular 1/2" sockets and tools, Chrome-Vanadium 31 Cr-V 3 (1.2208), chrome-plated, with ABS-module, in metal case



Art.-Nr. / No.	g	VE	EUR	Art.-Nr. / No.	g	VE	EUR
4115 00 04	5300	1	115,00	4115 01 02	5300	1	115,00
4060				4060			
4064				4064			
4065		125, 250mm		4065		125, 250mm	
4068				4068			
4070				4070			
4075		10;11;12;13;14;15;16;17;18;19;20;21;22;23;24;27;30;32mm		4075		3/8;7/16;1/2;9/16;19/32;5/8;11/16;3/4;25/32;13/16;7/8;15/16;31/32;1;1.1/16;1.1/8;1.3/16;1.1/4" AF	
4115 00 02	5300	1	115,00	4115 01 12	5300	1	118,00
4060				4061			
4115 00 14	5300	1	118,00				
4061							
4115 00 12	5300	1	118,00				
4061							

4115

1/2"-Satz, 24-tlg. 1/2" Socket Set, 24 pcs.

Satz mit den gängigsten 1/2"-Steckschlüssel-einsätzen und -Werkzeugen, mit Kurbel, Chrom-Vanadium-Stahl 31 Cr-V 3 (1.2208), matt verchromt, mit ABS-Einlage, im stabilen Metallkasten

Tool Set with the most popular 1/2" sockets and tools, with speed brace, Chrome-Vanadium 31 Cr-V 3 (1.2208), chrome-plated, with ABS-module, in metal case

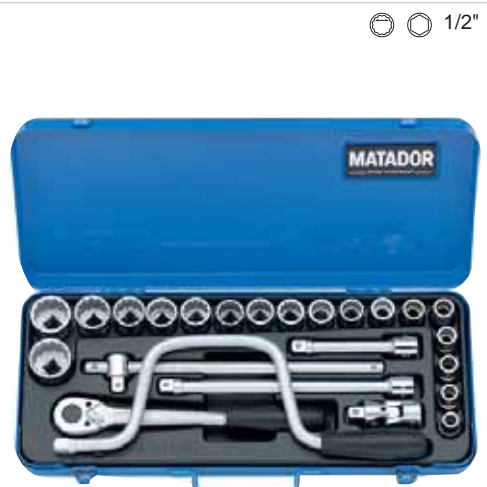

Art.-Nr. / No.	g	VE	EUR
4135 00 01	3600	1	155,00
4060			
4066			
442		TX 20, 25, 27, 30, 40	
620		TX 20, 25, 27, 30, 40	
4090		E 10, 12, 14, 18, 20, 24	
4092		TX 27, 30, 40, 45, 50, 55	
4135 00 02	3600	1	158,00
4061			
4135 00 03	3600	1	161,00
4061		Feinverzahnt / 72T	

4135

1/2"-Satz TORX, 24-tlg. 1/2" Socket Set TORX, 24 pcs.

TORX-Sortiment, 24-tlg., mit Schraubendreher-Einsätzen für Außen- und Innen-TORX-Schrauben, mit Winkelschraubendrehern und Schraubendrehern mit 2-Komponenten-Griffen, Chrom-Vanadium-Stahl 31 Cr-V 3 (1.2208), matt verchromt, mit ABS-Einlage, im stabilen Metallkasten

TORX Assortment, 24-pcs., with screwdriver sockets for inside and outside TORX screws, with allen keys and screwdrivers with dual compound handles, Chrome-Vanadium 31 Cr-V 3 (1.2208), chrome-plated, with ABS-module, in metal case

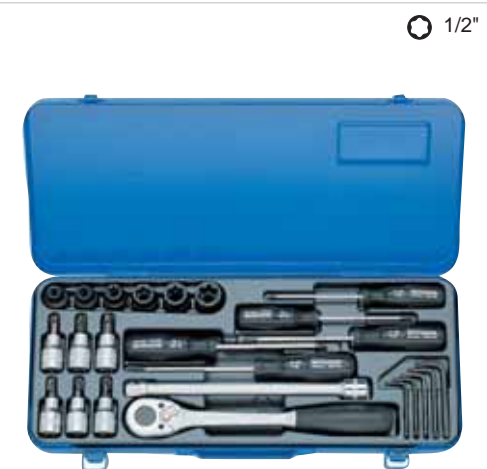

Steckschlüssel
Socket Sets

Steckschlüssel / Socket Sets

1/2"-Satz Kfz, 25-tlg. 1/2" Socket Set, 25 pcs.

1/2" 



















4114

Satz mit den gängigsten 1/2"-Steckschlüsselsätzen und -Werkzeugen, mit ModuFlex-System Größe L, Einlage in blau / schwarz, entnehmbar für Werkstattwagen, verchromt, Chrom-Vanadium, im stabilen Kunststoffkoffer

Tool Set with the most popular 1/2" sockets and tools, with ModuFlex-System size L, fits into workshop trolleys, chrome-plated, Chrome-Vanadium, in plastic case

ModuFlex L

Art.-Nr. / No.	g	VE	EUR	Art.-Nr. / No.	g	VE	EUR
4114 60 01	4600	1	95,00	4114 61 02	4600	1	95,00
4061				4061			
4064	 300mm			4064	 300mm		
4065	 125mm			4065	 125mm		
4066	 250mm			4066	 250mm		
4081	 16; 20,8mm			4081	 16; 20,8mm		
4075	 10; 11; 12; 13; 14; 15; 16; 17; 18; 19; 20; 21; 22; 23; 24; 27; 30; 32mm			4075	 3/8; 7/16; 1/2; 9/16; 19/32; 5/8; 11/16; 3/4; 25/32; 13/16; 7/8; 15/16; 31/32; 1; 1.1/16; 1.1/8; 1.3/16; 1.1/4" AF		
4114 60 02	4600	1	95,00	4114 61 04	4600	1	98,00
4061	 Feinverzahnt / 72T			4061	 Feinverzahnt / 72T		
4114 60 03	4600	1	98,00	AF nur in Zwölfkant / AF only 12-pt.			
4061	 Feinverzahnt / 72T						
4114 60 04	4600	1	98,00				
4061	 Feinverzahnt / 72T						

1/2"-Satz Universal, 44-tlg. 1/2" Socket Set Universal, 44 pcs.

1/2" 





















4140

Satz mit 1/2"-TORX-Schraubendrehereinsätzen für Innen- und Außen-TORX-Schrauben, mit ModuFlex-System Größe L, Einlage in blau / schwarz, entnehmbar für Werkstattwagen, verchromt, Chrom-Vanadium, im stabilen Kunststoffkoffer

Tool Set with 1/2" screwdriver sockets for inside and outside TORX screws, with ModuFlex-System size L, fits into workshop trolleys, chrome-plated, Chrome-Vanadium, in plastic case

ModuFlex L

Art.-Nr. / No.	g	VE	EUR	Art.-Nr. / No.	g	VE	EUR
4140 00 01	5250	1	165,00	4140 01 02	5250	1	165,00
4061				4061			
4064	 300mm			4064	 300mm		
4065	 125, 250mm			4065	 125, 250mm		
4068	 4084 			4068	 4084 		
4075	 10; 11; 12; 13; 14; 15; 16; 17; 18; 19; 20; 21; 22; 23; 24; 27; 30; 32mm			4075	 3/8; 7/16; 1/2; 9/16; 19/32; 5/8; 11/16; 3/4; 25/32; 13/16; 7/8; 15/16; 31/32; 1; 1.1/16; 1.1/8; 1.3/16; 1.1/4" AF		
4078	 5, 6, 7, 8, 10, 12, 14 x 60mm			4078	 5, 6, 7, 8, 10, 12, 14 x 60mm		
7024	PH 1, 2, 3, 4 / 0,6; 0,8; 1,2; 1,6			7024	PH 1, 2, 3, 4 / 0,6; 0,8; 1,2; 1,6		
7025	TX 20, 25, 27, 30, 40			7025	TX 20, 25, 27, 30, 40		
4140 00 02	5250	1	165,00	4140 01 04	5250	1	168,00
4061	 Feinverzahnt / 72T			4061	 Feinverzahnt / 72T		
4140 00 03	5250	1	168,00	AF nur in Zwölfkant / AF only 12-pt.			
4061	 Feinverzahnt / 72T						
4140 00 04	5250	1	168,00				
4061	 Feinverzahnt / 72T						

1/2"-Satz TORX, 26-tlg. 1/2" Socket Set, 26 pcs.

1/2" 





















4141

Satz mit 1/2"-TORX-Steckschlüsselsätzen für Innen- und Außen-TORX-Schrauben, mit ModuFlex-System Größe L, Einlage in blau / schwarz, entnehmbar für Werkstattwagen, verchromt, Chrom-Vanadium, im stabilen Kunststoffkoffer

Tool Set with 1/2" screwdriver sockets for inside and outside TORX screws, with ModuFlex-System size L, fits into workshop trolleys, chrome-plated, Chrome-Vanadium, in plastic case

ModuFlex L

Art.-Nr. / No.	g	VE	EUR	Art.-Nr. / No.	g	VE	EUR
4141 60 01	5300	1	115,00	4141 61 02	5300	1	115,00
4061				4061			
4064	 300mm			4064	 300mm		
4065	 125, 250mm			4065	 125, 250mm		
4068				4068			
4075	 10; 11; 12; 13; 14; 15; 17; 19; 22; 24; 27; 30; 32mm			4075	 3/8; 7/16; 15/32; 1/2; 9/16; 19/32; 21/32; 3/4; 7/8; 1; 1.1/16; 1.1/8; 1.1/4" AF		
4090	 E 10, 12, 14, 18			4090	 E 10, 12, 14, 18		
4092	 TX 45, 50, 55, 60 x 60			4092	 TX 45, 50, 55, 60 x 60		
4141 60 02	5300	1	115,00	4141 61 04	5300	1	118,00
4061	 Feinverzahnt / 72T			4061	 Feinverzahnt / 72T		
4141 60 03	5300	1	118,00	AF nur in Zwölfkant / AF only 12-pt.			
4061	 Feinverzahnt / 72T						
4141 60 04	5300	1	118,00				
4061	 Feinverzahnt / 72T						

Art.-Nr. / No.	↔ mm	⚖ g	📦 VE	EUR	
5060 00 02	500	1480	5	115,00	<p>5060</p> <p>Völlig neu entwickelte Umschaltknarre, nach DIN 3122 D / ISO 3315, feinverzahnt, extrem hohe Drehmomentwerte (garantiert 1.600 Nm!), gummierter Griff für mehr Halt, Chrom-Vanadium-Stahl 31 Cr-V 3 (1.2208), matt verchromt</p> <p>New developed reversible ratchet, according to DIN 3122 D / ISO 3315, 72 T, very high torque power (guaranteed 1,600Nm), handle with special grip, Chrome-Vanadium 31 Cr-V 3 (1.2208), matt chrome-plated</p>
Reparaturset / Repair Kit 5060 00 11		500	1	50,00	

Umschaltknarre
Reversible Ratchet

3/4"
 72T



Feinverzahnt / 72T



Umschaltbar / Reversible



1600Nm Drehmoment / Torque Power

Art.-Nr. / No.	↔ mm	⚖ g	📦 VE	EUR	
5062 00 01	500 kpl. / compl.	1400	5	69,50	<p>5062</p> <p>Nach DIN 3122 D / ISO 3315, 36 Zähne, Chrom-Vanadium-Stahl 31 Cr-V 3 (1.2208), matt verchromt</p> <p>According to DIN 3122 D / ISO 3315, 36 teeth, Chrome-Vanadium 31 Cr-V 3 (1.2208), matt chrome-plated</p>
5062 00 02	42	135	5	7,20	

Durchsteckknarre
Ratchet, Push-Thru-Type

3/4"



Art.-Nr. / No.	↔ mm	⚖ g	📦 VE	EUR	
5064 00 01	500	1420	5	32,50	<p>5064</p> <p>Nach DIN 3122 A / ISO 3315, Chrom-Vanadium-Stahl 31 Cr-V 3 (1.2208), matt verchromt</p> <p>According to DIN 3122 A / ISO 3315, Chrome-Vanadium 31 Cr-V 3 (1.2208), chrome-plated</p>
0506 40 01	65	300	1	13,00	

Gleitgriff
Sliding T-Handle

3/4"



Steckschlüssel / Socket Sets

Verlängerungen Extensions

3/4"



5065

Nach DIN 3123 B / ISO 3316, Chrom-Vanadium-Stahl 31 Cr-V 3 (1.2208), matt verchromt

According to DIN 3123 B / ISO 3316, Chrome-Vanadium 31 Cr-V 3 (1.2208), chrome-plated

Art.-Nr. / No.

mm

g VE

EUR

5065 00 01
5066 00 01

210
420

520 5 20,75
980 5 28,00

Kardangeln Universal Joint

3/4"



5068

Nach DIN 3123 C / ISO 3316, Chrom-Vanadium-Stahl 31 Cr-V 3 (1.2208), matt verchromt

According to DIN 3123 C / ISO 3316, Chrome-Vanadium 31 Cr-V 3 (1.2208), chrome-plated

Art.-Nr. / No.

mm

g VE

EUR

5068 00 01

115

470 5 61,00

Verbindungsstücke Socket Converters

1"



3/4"

3/4"



1"

6082/6083

DIN 3123 A / ISO 3316, Chrom-Vanadium-Stahl 31 Cr-V 3 (1.2208), matt verchromt

According to DIN 3123 A / ISO 3316, Chrome-Vanadium 31 Cr-V 3 (1.2208), chrome-plated

Art.-Nr. / No.

mm

mm

g VE

EUR

6082 00 01
6083 00 01

3/4" 1"
1" 3/4"

500 1 24,20
500 1 25,20

Steckschlüssel-Einsätze Sockets

3/4"



5075

Passend für Außensechskant-Schrauben, Zwölfkant-Profil, nach DIN 3120 / ISO 1174, für Handbetätigung, Chrom-Vanadium-Stahl, 31 Cr-V 3 (1.2208), matt verchromt

For outside hexagon screws, 12-pt., 3/4"-square drive acc. to DIN 3120 / ISO 1174, for manual drive, Chrome-Vanadium 31 Cr-V 3 (1.2208), matt chrome-plated

Art.-Nr. / No.

mm

mm

g VE

EUR

5075 00 01
5075 00 02
5075 00 03
5075 00 04
5075 00 05
5075 00 06
5075 00 07
5075 00 10
5075 00 12
5075 00 14
5075 00 16
5075 00 18
5075 00 21
5075 00 23

19 51
22 51
24 52
27 54
30 56
32 56
33 56
36 65
38 65
41 65
46 65
50 65
55 70
60 70

180 5 9,80
220 5 9,80
200 5 9,80
220 5 10,80
250 5 11,50
285 5 11,50
285 5 11,50
400 5 15,95
460 5 16,95
490 5 20,50
650 5 23,50
700 5 27,50
760 1 35,20
870 1 42,00

Art.-Nr. / No.	mm	mm	g	VE	EUR
5075 00 30	19	51	180	5	9,80
5075 00 31	22	51	200	5	9,80
5075 00 32	24	52	200	5	9,80
5075 00 33	27	54	260	5	10,80
5075 00 34	30	56	280	5	11,50
5075 00 35	32	56	320	5	11,50
5075 00 36	36	65	400	5	11,50
5075 00 37	38	65	460	5	15,95
5075 00 38	41	65	490	5	16,95
5075 00 39	46	65	650	5	20,50
5075 00 40	50	65	760	5	23,50
5075 00 41	55	70	860	1	27,50
5075 00 42	60	70	900	1	35,20

5075

Steckschlüssel-Einsätze Sockets

Passend für Außensechskant-Schrauben, Sechskant-Profil, nach DIN 3120 / ISO 1174, für Handbetätigung, Chrom-Vanadium-Stahl, 31 Cr-V 3 (1.2208), matt verchromt

For outside hexagon screws, 6-pt., 3/4"-square drive acc. to DIN 3120 / ISO 1174, for manual drive, Chrome-Vanadium 31 Cr-V 3 (1.2208), matt chrome-plated



Art.-Nr. / No.	mm	mm	g	VE	EUR
5075 01 02	7/8	52	200	5	10,20
5075 01 03	15/16	52	200	5	10,20
5075 01 04	1	52	250	5	10,70
5075 01 05	1.1/16	54	260	5	10,70
5075 01 08	1.1/4	56	320	5	11,90
5075 01 11	1.7/16	65	420	5	17,50
5075 01 12	1.1/2	65	460	5	17,80
5075 01 13	1.5/8	65	490	5	20,90
5075 01 16	1.13/16	65	650	5	25,00
5075 01 18	2	65	700	5	32,50
5075 01 22	2.1/4	70	820	1	43,50



500to EUMUCO-Schmiedepresse bei MATADOR - Made in Germany
500 tons EUMUCO forging press at MATADOR - Made in Germany

Art.-Nr. / No.	g	VE	EUR	Art.-Nr. / No.	g	VE	EUR
5142 00 02	12700	1	245,00	5142 01 01	12700	1	245,00
5062				5062			
5064	500mm			5064	500mm		
5065	210mm			5065	210mm		
5066	420mm			5066	420mm		
5075	22; 24; 27; 30; 32; 36; 38; 41; 46; 50mm			5075	7/8; 15/16; 1; 1.1/16; 1.1/4; 1.7/16; 1.1/2; 1.5/8; 1.13/16; 2"AF		
5142 00 01	12700	1	245,00	5142 01 02	12700	1	285,00
5062				5060	Feinverzahnt / 72T		
5142 00 04	12700	1	285,00				
5060	Feinverzahnt / 72T						
5142 00 03	12700	1	285,00				
5060	Feinverzahnt / 72T						

5142

3/4"-Satz, 14-tlg. 3/4" Socket Set, 14 pcs.

Satz mit 3/4"-Steckschlüsseleinsätzen und -Werkzeugen, Chrom-Vanadium-Stahl 31 Cr-V 3 (1.2208), matt verchromt, mit ABS-Einlage, im stabilen Metallkasten

Tool Set with the most popular 3/4" sockets and tools, Chrome-Vanadium 1.2208, chrome-plated, with ABS-module, in metal case



Art.-Nr. / No.	g	VE	EUR
5143 00 02	13500	1	310,00
5062			
5064	500mm		
5065	210mm		
5066	420mm		
5075	22; 24; 27; 30; 32; 36; 38; 41; 46; 50; 55; 60mm		
5143 00 01	13500	1	310,00
5062			
5143 00 04	13500	1	345,00
5060			
5143 00 03	13500	1	345,00
5060			

5143

3/4"-Satz, 16-tlg. 3/4" Socket Set, 16 pcs.

Satz mit 3/4"-Steckschlüsseleinsätzen und -Werkzeugen, Chrom-Vanadium-Stahl 31 Cr-V 3 (1.2208), matt verchromt, mit ABS-Einlage, im stabilen Metallkasten

Tool Set with the most popular 3/4" sockets and tools, Chrome-Vanadium 1.2208, chrome-plated, with ABS-module, in metal case



Steckschlüssel / Socket Sets

Umschaltknarre Reversible Ratchet

☐ 1"



6060

Nach DIN 3122 D / ISO 3315, feinverzahnt mit 60 Zähnen, mit Stiftsicherung, Chrom-Vanadium-Stahl 31 Cr-V 3 (1.2208), matt verchromt

According to DIN 3122 D / ISO 3315, 60 T, with safety pin locking system, Chrome-Vanadium 31 Cr-V 3 (1.2208), matt chrome-plated

Art.-Nr. / No.	↔ mm	⚖ g	📦 VE	EUR
6060 00 01	610	3370	1	198,00
Reparaturatz / Repair Kit				
6060 00 10		560	1	50,00

Gerüstbauknarre, umschaltbar Reversible Construction Ratchet

☐ 1"



6200

Gerüstbauknarre, mit 2 Schlüsselweiten (19 und 22mm), Zwölfkant, mit Zentrierspitze, brüniert

Reversible-Construction-Ratchet, with 2 different sizes (19 and 22mm), 12-pt., with centre punch

Art.-Nr. / No.	⊘ mm	↔ mm	⚖ g	📦 VE	EUR
6200 19 22	19x22	310	500	1	36,50



Verbindungsstücke Socket Converters

3/4" 1"



1" 3/4"



6082 / 6083

DIN 3123 A / ISO 3316, Chrom-Vanadium-Stahl 31 Cr-V 3 (1.2208), matt verchromt

According to DIN 3123 A / ISO 3316, Chrome-Vanadium 31 Cr-V 3 (1.2208), chrome-plated

Art.-Nr. / No.	⊘ mm	⊘ mm	⚖ g	📦 VE	EUR
6082 00 02	3/4"	1"	500	1	24,20
6083 00 01	1"	3/4"	500	1	25,20

Gleitgriff Sliding T-Handle

☐ 1"



6064

Nach DIN 3122 A / ISO 3315, Chrom-Vanadium-Stahl 31 Cr-V 3 (1.2208), matt verchromt

According to DIN 3122 A / ISO 3315, Chrome-Vanadium 31 Cr-V 3 (1.2208), chrome-plated

Gleitkopf lose, nach DIN 3122 / ISO 3315, Chrom-Vanadium-Stahl 31 Cr-V 3 (1.2208), matt verchromt

Single sliding head, according to DIN 3122 / ISO 3315, Chrome-Vanadium 31 Cr-V 3 (1.2208), chrome-plated

Art.-Nr. / No.	↔ mm	⚖ g	📦 VE	EUR
6064 00 01	640	3250	1	64,00
0606 40 01	80	400	1	19,00

Art.-Nr. / No.	↔ mm	⚖ g	📦 VE	EUR	6065
6065 00 01	205	1150	1	45,90	Nach DIN 3123 B / ISO 3316, Chrom-Vanadium-Stahl 31 Cr-V 3 (1.2208), matt verchromt According to DIN 3123 B / ISO 3316, Chrome-Vanadium 31 Cr-V 3 (1.2208), chrome-plated
6066 00 02	405	1900	1	59,00	





Verlängerungen Extensions



Art.-Nr. / No.	⊘ mm	↔ mm	⚖ g	📦 VE	EUR	6075
6075 00 01	36	64	650	1	29,90	Passend für Außensechskant-Schrauben, Zwölfkant-Profil, nach DIN 3120 / ISO 1174, für Handbetätigung, Chrom-Vanadium-Stahl, 31 Cr-V 3 (1.2208), matt verchromt
6075 00 02	41	69	750	1	34,60	
6075 00 03	46	73	900	1	40,50	Für outside hexagon screws, 12-pt., 3/4"-square drive acc. to DIN 3120 / ISO 1174, for manual drive, Chrome-Vanadium 31 Cr-V 3 (1.2208), matt chrome-plated
6075 00 04	50	77	1000	1	45,50	
6075 00 05	55	82	1100	1	53,50	
6075 00 06	60	86	1400	1	59,50	
6075 00 07	65	91	1600	1	66,50	
6075 00 08	70	95	1750	1	75,00	
6075 00 09	75	100	2100	1	83,00	
6075 00 10	80	105	2300	1	91,00	

Steckschlüssel-Einsätze Sockets



Art.-Nr. / No.	⚖ g	📦 VE	EUR	6144
6144 00 01	28500	1	650,00	Satz mit den gängigsten 1"-Steckschlüsseleinsätzen und -Werkzeugen, im stabilen Metallkasten Tool Set with the most popular 1" sockets and tools, in metal case
6060				
6064	 640mm			
6065	 205mm			
6066	 405mm			
6075	 36; 41; 46; 50; 55; 60; 65; 70; 75; 80mm			

1"-Satz, 14-tlg. 1" Socket Set, 14 pcs.



Made in Germany.



Kraft-Steckschlüssel / Impact Sockets

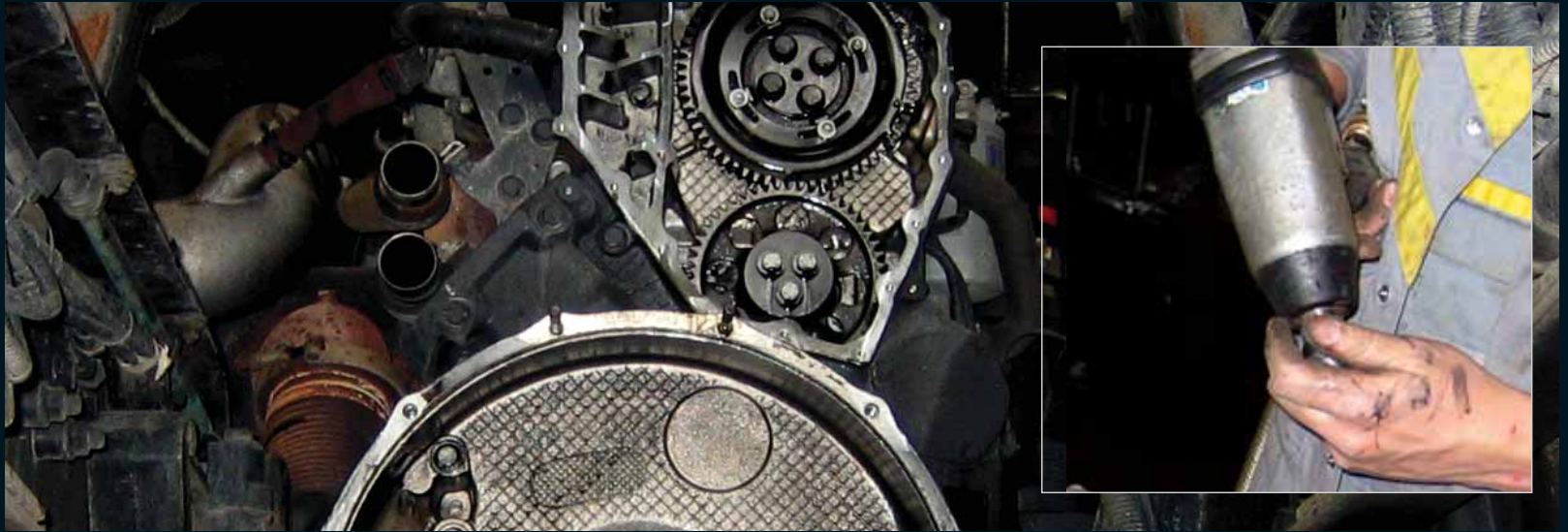

Kraft-Steckschlüssel-Einsätze Impact Sockets

□ 1/4"



7010

Passend für Außensechskant-Schrauben, mit Sechskant-Profil, nach DIN 3129 / ISO 2725-2, für alle elektrisch oder mit Druckluft angetriebenen Maschinenschrauber (Schlagschrauber), Sicherung mit Verbindungsstift und O-Ring, Chrom-Vanadium-Spezialstahl, brüniert / schwarz

For heavy duty applications, for outside hexagon screws, 6-pt., according to DIN 3129 / ISO 2725-2, suitable for all types of electric and pneumatic screw driving machines (impact wrenches), Chrome-Vanadium special steel, surface burnished, black

Art.-Nr. / No.	⊘ mm	↔ mm	⚖ g	📦 VE	EUR
7010 00 01	4	24	14	10	5,20
7010 00 02	4,5	24	14	10	5,20
7010 00 03	5	24	14	10	5,30
7010 00 04	5,5	24	14	10	5,30
7010 00 06	6	24	14	10	5,30
7010 00 07	7	24	15	10	5,30
7010 00 08	8	24	15	10	5,30
7010 00 09	9	24	15	10	5,35
7010 00 10	10	24	17	10	5,35
7010 00 11	11	24	17	10	5,40
7010 00 12	12	24	18	10	5,40
7010 00 13	13	24	20	10	5,50
7010 00 14	14	24	24	10	5,50

Kraft-Verbindungsstück Impact Socket Converter

3/8" 1/4"



7011

Für alle elektrisch oder mit Druckluft angetriebenen Maschinenschrauber (Schlagschrauber), Sicherung mit Verbindungsstift und O-Ring, Chrom-Vanadium-Spezialstahl, brüniert / schwarz

Suitable for all types of electric and pneumatic screw driving machines (impact wrenches), Chrome-Vanadium special steel, surface burnished, black

Art.-Nr. / No.	⊘ mm	□ mm	⚖ g	📦 VE	EUR
7011 00 01	1/4"	3/8"	50	10	17,00

Kraft-Verlängerung Impact Extension

□ 3/8"



7012

Für alle elektrisch oder mit Druckluft angetriebenen Maschinenschrauber (Schlagschrauber), Sicherung mit Verbindungsstift und O-Ring, Chrom-Vanadium-Spezialstahl, brüniert / schwarz

Suitable for all types of electric and pneumatic screw driving machines (impact wrenches), Chrome-Vanadium special steel, surface burnished, black

Art.-Nr. / No.	↔ mm	⚖ g	📦 VE	EUR
7012 00 01	75	90	5	14,50

Art.-Nr. / No.	mm	mm	g	VE	EUR	7015
7015 00 01	8	32	40	10	6,90	<p>Passend für Außensechskant-Schrauben, mit Sechskant-Profil, nach DIN 3129 / ISO 2725-2, für alle elektrisch oder mit Druckluft angetriebenen Maschinenschrauber (Schlagschrauber), Sicherung mit Verbindungsstift und O-Ring, Chrom-Vanadium-Spezialstahl, brüniert / schwarz</p> <p>For heavy duty applications, for outside hexagon screws, 6-pt., according to DIN 3129 / ISO 2725-2, suitable for all types of electric and pneumatic screw driving machines (impact wrenches), Chrome-Vanadium special steel, surface burnished, black</p>
7015 00 02	9	32	40	10	6,90	
7015 00 03	10	32	40	10	6,90	
7015 00 04	11	32	50	10	6,90	
7015 00 05	12	32	58	10	7,80	
7015 00 06	13	32	58	10	7,80	
7015 00 07	14	32	58	10	8,50	
7015 00 08	15	32	58	10	8,80	
7015 00 09	16	32	60	10	9,30	
7015 00 10	17	32	65	10	9,90	

Kraft-Steckschlüssel-Einsätze Impact Sockets



Art.-Nr. / No.	g	VE	EUR	ModuFlex S 773	
0773 00 01	10-tlg. / pcs. 10, 11, 12, 13, 14 15, 16, 17, 19mm + Bolzen / Pin	700	1	145,00	<p>Zum Lösen extrem beschädigter Muttern und Schrauben durch spezielles Spiral-Nuten-Profil, mit 3/8"-Antrieb, schlagschraubergeeignet, mit Ausschlagbolzen zum Ausschlagen der gelösten Schrauben und Muttern aus dem Einsatz, Spezialstahl, brüniert / schwarz</p> <p>Quickly and easily remove damaged or rounded nuts and bolts, simply place socket on fastener and turn with impact gun, no hammering required to install socket over fastener, applications include oil pan drain plugs, exhaust manifold nuts, studs, pipe nipples and corroded marine fasteners, special steel, black phosphated, 3/8"</p>

Schraubenausdreher-Satz Twist Socket Set



Art.-Nr. / No.	mm	g	VE	EUR	7056
7056 00 01	75	130	5	14,75	<p>Für alle elektrisch oder mit Druckluft angetriebenen Maschinenschrauber (Schlagschrauber), Sicherung mit Verbindungsstift und O-Ring, Chrom-Vanadium-Spezialstahl, brüniert / schwarz</p> <p>Suitable for all types of electric and pneumatic screw driving machines (impact wrenches), Chrome-Vanadium special steel, surface burnished, black</p>
7056 00 02	125	200	5	15,20	
7056 00 03	250	400	5	19,50	

Kraft-Verlängerungen Impact Extensions



Art.-Nr. / No.	1/2"	3/8"	g	VE	EUR	7057
7057 00 01	1/2"	3/8"	77	1	15,00	<p>Für alle elektrisch oder mit Druckluft angetriebenen Maschinenschrauber (Schlagschrauber), Sicherung mit Verbindungsstift und O-Ring, Chrom-Vanadium-Spezialstahl, brüniert / schwarz</p> <p>Suitable for all types of electric and pneumatic screw driving machines (impact wrenches), Chrome-Vanadium special steel, surface burnished, black</p>
7057 00 02	1/2"	3/4"	180	1	16,20	

Kraft-Verbindungsstücke Impact Socket Converters



Steckschlüssel
Socket Sets

Kraft-Steckschlüssel / Impact Sockets

Kraft-Kardangeln Impact Universal Joint

1/2"



7058

Für alle elektrisch oder mit Druckluft angetriebenen Maschinenschrauber (Schlagschrauber), Sicherung mit Verbindungsstift und O-Ring, Chrom-Vanadium-Spezialstahl, brüniert / schwarz

Suitable for all types of electric and pneumatic screw driving machines (impact wrenches), Chrome-Vanadium special steel, surface burnished, black

Art.-Nr. / No.	mm	g	VE	EUR
----------------	----	---	----	-----

7058 00 01	85	185	1	21,50
------------	----	-----	---	-------

Kraft-Steckschlüssel-Einsätze Impact Sockets

1/2"



7055

Passend für Außensechskant-Schrauben, mit Sechskant-Profil, nach DIN 3129 / ISO 2725-2, für alle elektrisch oder mit Druckluft angetriebenen Maschinenschrauber (Schlagschrauber), Sicherung mit Verbindungsstift und O-Ring, Chrom-Vanadium-Spezialstahl, brüniert / schwarz

For heavy duty applications, for outside hexagon screws, 6-pt., according to DIN 3129 / ISO 2725-2, suitable for all types of electric and pneumatic screw driving machines (impact wrenches), Chrome-Vanadium special steel, surface burnished, black

Art.-Nr. / No.	mm	mm	g	VE	EUR
----------------	----	----	---	----	-----

7055 00 01	10	38	92	10	5,75
7055 00 02	11	38	93	10	5,75
7055 00 03	12	38	95	10	5,75
7055 00 04	13	38	97	10	5,75
7055 00 05	14	38	100	10	7,75
7055 00 06	15	38	100	10	6,40
7055 00 13	16	38	140	10	6,40
7055 00 07	17	38	140	10	6,60
7055 00 14	18	38	140	10	6,60
7055 00 08	19	38	150	10	6,80
7055 00 16	20	38	160	10	6,80
7055 00 15	21	38	160	10	7,70
7055 00 09	22	38	160	10	7,70
7055 00 10	24	45	170	10	8,20
7055 00 11	27	50	180	10	10,30
7055 00 12	30	50	190	10	10,90
7055 00 17	32	50	190	10	11,80

1/2"-Satz Kraft-Einsätze, 14-tlg. 1/2" Impact Socket Set, 14-pcs.

1/2"



7055

Satz mit den gängigsten 1/2"-Kraft-Steckschlüssel-einsätzen, für alle elektrisch oder mit Druckluft angetriebenen Maschinenschrauber (Schlagschrauber), mit Verbindungsstiften und O-Ringen, Chrom-Vanadium-Spezialstahl, brüniert / schwarz, im stabilen Metallkasten

Tool Set with the most popular 1/2" impact sockets, suitable for all types of electric and pneumatic screw driving machines (impact wrenches), with impact retaining rings and pins, Chrome-Vanadium special steel, surface burnished, black, in metal case

Art.-Nr. / No.	g	VE	EUR
----------------	---	----	-----

7055 10 40	14-tlg. / pcs.	1300	1	78,50
------------	----------------	------	---	-------

7099	Stifte Pins	1x 10-14mm 1x 15-30mm		
7099	Ringe Rings	1x 10-14mm 1x 15-30mm		
7055		10; 11; 13; 14; 15; 17; 19; 21; 22; 24mm		

Kraft-Steckschlüssel-Einsätze Impact Sockets, long type

1/2"



7055

Lange Ausführung, passend für Außensechskant-Schrauben, mit Sechskant-Profil, für alle elektrisch oder mit Druckluft angetriebenen Maschinenschrauber (Schlagschrauber), Sicherung mit Verbindungsstift und O-Ring, Chrom-Vanadium-Spezialstahl, brüniert / schwarz

Long type, for heavy duty applications, for outside hexagon screws, 6-pt., suitable for all types of electric and pneumatic screw driving machines (impact wrenches), Chrome-Vanadium special steel, surface burnished, black

Art.-Nr. / No.	mm	mm	g	VE	EUR
----------------	----	----	---	----	-----

7055 00 40	10	78	155	5	11,20
7055 00 30	13	78	175	5	11,20
7055 00 41	14	78	175	5	11,20
7055 00 42	15	78	270	5	11,20
7055 00 31	16	78	270	5	11,20
7055 00 32	17	78	255	5	11,20
7055 00 33	18	78	230	5	11,80
7055 00 34	19	78	230	5	11,80
7055 00 43	20	78	220	5	12,50
7055 00 35	21	78	220	5	12,50
7055 00 36	22	78	230	5	12,60
7055 00 37	24	78	270	5	15,20
7055 00 38	27	78	360	5	16,40
7055 00 39	30	78	510	5	19,20
7055 00 44	32	78	560	5	19,50

Art.-Nr. / No.	mm	mm	g	VE	EUR	7055
7055 21 70	17	85	188	1	9,95	Kraft-Einsätze mit Kunststoffeinsatz und Kunststoffhülsen (außen) zum Schutz der Felgen beim Ansetzen der Radmutter, lange Ausführung, mit Sechskant-Profil, für alle elektrisch oder mit Druckluft angetriebenen Maschinenschrauber (Schlagschrauber), Chrom-Vanadium-Spezialstahl
7055 21 90	19	85	216	1	9,95	
7055 22 10	21	85	234	1	9,95	
3-tlg. Satz im Kunststoffkasten / 3-pcs. set in plastic case						
7055 20 01	17, 19, 21mm		755	1	24,50	Impact sockets with additional outside plastic sleeve to protect the rims when screwing the wheel nuts, long type, 6-pt., suitable for all types of electric and pneumatic screw driving machines (impact wrenches), Chrome-Vanadium special steel



Kraft-Steckschlüssel-Einsätze Impact Sockets



Art.-Nr. / No.	g	VE	EUR	7056
7056 10 40	2100	1	115,00	Satz mit den gängigsten 1/2"-Kraft-Steckschlüssel-einsätzen, lange Ausführung, für alle elektrisch oder mit Druckluft angetriebenen Maschinenschrauber (Schlagschrauber), mit Verbindungsstiften und O-Ringen, Chrom-Vanadium-Spezialstahl, brüniert / schwarz, im stabilen Metallkasten
7099	Stifte Pins	1x 10-14mm 1x 15-30mm		
7099	Ringe Rings	1x 10-14mm 1x 15-30mm		
7055	10; 13; 15; 17; 18; 19; 21; 22; 24mm			Tool Set with the most popular 1/2" impact sockets, long type, suitable for all types of electric and pneumatic screw driving machines (impact wrenches), with impact retaining rings and pins, Chrome-Vanadium special steel, surface burnished, black, in metal case

1/2"-Satz Kraft-Einsätze, 13-tlg. 1/2" Impact Socket Set, 13-pcs.



Art.-Nr. / No.	E	mm	g	VE	EUR	4087
4087 00 01	E 20	130	242	1	39,50	Mit 1/2"-Antrieb und Innen-TORX E 20, z.B. für MAN-F 2000, F 90 und F 80 sowie für Busse mit Motoren D 25 und D 28 (MAN-Nr. 80.99603.0255); zum Lösen bzw. Festziehen der Zylinderkopfschrauben; Entfernung der Einspritzdüse und der spätere Wiedereinbau überflüssig (Zeitersparnis 2,5 Stunden)
With 1/2"-drive and inside TORX E 20 for tightening and loosening the cylinder head screws of MAN-F-2000, F 90 and F 80 and for buses with D 25 and D 28 engines (MAN-No. 80.99603.0255); according to the servicing schedule; no need to remove and re-install the injection nozzle (saves up to 2,5 hours working time)						

Zylinderkopf-Schlüssel Cylinder Head Wrench



Art.-Nr. / No.	mm	g	VE	EUR	7059	
7059 00 06	M8	100	105	10	13,70	Passend für B&S-XZN - Schrauben, für alle elektrisch oder mit Druckluft angetriebenen Maschinenschrauber (Schlagschrauber), Sicherung mit Verbindungsstift und O-Ring, Chrom-Vanadium-Spezialstahl, brüniert / schwarz
7059 00 08	M10	100	110	10	16,50	
7059 00 11	M12	140	120	10	17,10	
Für B&S-XZN screws, suitable for all types of electric and pneumatic screw driving machines (impact wrenches), Chrome-Vanadium special steel, surface burnished, black						

Kraft-Einsätze, B&S-XZN Impact Sockets, B&S XZN



Steckschlüssel
Socket Sets

Kraft-Steckschlüssel / Impact Sockets

Kraft-Einsätze, Innensechskant Impact Sockets, inside hexagon

1/2"



7061

Passend für Innensechskant-Schrauben (DIN 7426 / ISO 3109), für alle elektrisch oder mit Druckluft angetriebenen Maschinenschrauber (Schlagschrauber), Sicherung mit Verbindungsstift und O-Ring, Chrom-Vanadium-Spezialstahl, brüniert / schwarz

For heavy duty applications, for inside hexagon screws (DIN 7426 / ISO 3109), suitable for all types of electric and pneumatic screw driving machines (impact wrenches), Chrome-Vanadium special steel, surface burnished, black

Art.-Nr. / No.	mm	mm	g	VE	EUR
7061 00 01	10	75	120	10	15,20
7061 00 02	11	75	125	10	15,20
7061 00 03	12	75	130	10	15,20
7061 00 04	13	75	140	10	15,20
7061 00 05	14	75	150	10	16,80
7061 00 06	15	75	155	10	18,10
7061 00 07	17	75	175	10	18,10
7061 00 08	19	75	200	10	18,50

Kraft-Einsätze, TORX Impact Sockets, TORX

1/2"



7060

Passend für Innen-TORX-Schrauben, für alle elektrisch oder mit Druckluft angetriebenen Maschinenschrauber (Schlagschrauber), Sicherung mit Verbindungsstift und O-Ring, Chrom-Vanadium-Spezialstahl, brüniert / schwarz

For heavy duty applications, for inside TORX screws, suitable for all types of electric and pneumatic screw driving machines (impact wrenches), Chrome-Vanadium special steel, surface burnished, black

Art.-Nr. / No.	E	mm	g	VE	EUR
7060 00 01	E 10	38	68	10	9,50
7060 00 02	E 12	38	70	10	9,50
7060 00 03	E 14	38	75	10	9,50
7060 00 07	E 16	38	80	10	9,70
7060 00 04	E 18	38	115	10	9,70
7060 00 05	E 20	38	130	10	9,70
7060 00 06	E 24	38	150	10	10,20

1/2"-Satz Kraft-Einsätze, 6-tlg. 1/2" Impact Socket Set, 6-pcs.

1/2"



7060

Satz mit den gängigsten Kraft-Einsätzen für Außen-TORX-Schrauben, für alle elektrisch oder mit Druckluft angetriebenen Maschinenschrauber (Schlagschrauber), Sicherung mit Verbindungsstift und O-Ring, Chrom-Vanadium-Spezialstahl, brüniert / schwarz, im stabilen Metallkasten

Tool Set with the most popular 1/2" impact sockets for outside TORX screws, suitable for all types of electric and pneumatic screw driving machines (impact wrenches), with impact retaining rings and pins, Chrome-Vanadium special steel, surface burnished, black, in metal case

Art.-Nr. / No.	g	VE	EUR
7060 00 40 6-tlg. / pcs.	900	1	58,50

Inhalt / contents
E 10, 12, 14, 18, 20, 24

Kraft-Einsätze, TORX Impact Sockets, TORX

1/2"







7062

Passend für Außen-TORX-Schrauben, für alle elektrisch oder mit Druckluft angetriebenen Maschinenschrauber (Schlagschrauber), Sicherung mit Verbindungsstift und O-Ring, Chrom-Vanadium-Spezialstahl, brüniert / schwarz

For heavy duty applications, for outside TORX screws, suitable for all types of electric and pneumatic screw driving machines (impact wrenches), Chrome-Vanadium special steel, surface burnished, black

Art.-Nr. / No.	TX	mm	g	VE	EUR
7062 00 01	TX 20	55	68	10	12,20
7062 00 02	TX 25	55	70	10	12,20
7062 00 03	TX 27	55	75	10	12,20
7062 00 04	TX 30	55	80	10	12,50
7062 00 05	TX 40	55	115	10	12,50
7062 00 06	TX 45	55	130	10	12,50
7062 00 07	TX 50	55	150	5	14,80
7062 00 08	TX 55	55	160	5	14,80
7062 00 09	TX 60	55	170	5	14,80
7062 00 10	TX 70	55	180	5	15,50

Art.-Nr. / No.					g VE	EUR	7067
7067 00 01	3/4"	1/2"	360	1	18,50		Für alle elektrisch oder mit Druckluft angetriebenen Maschinenschrauber (Schlagschrauber), Sicherung mit Verbindungsstift und O-Ring, Chrom-Vanadium-Spezialstahl, brüniert / schwarz Suitable for all types of electric and pneumatic screw driving machines (impact wrenches), Chrome-Vanadium special steel, surface burnished, black
7067 00 02	3/4"	1"	440	1	24,50		



Kraft-Verbindungsstücke Impact Socket Converters



Art.-Nr. / No.				g VE	EUR	7068
7068 00 01	105	600	1	52,50		Für alle elektrisch oder mit Druckluft angetriebenen Maschinenschrauber (Schlagschrauber), Sicherung mit Verbindungsstift und O-Ring, Chrom-Vanadium-Spezialstahl, brüniert / schwarz Suitable for all types of electric and pneumatic screw driving machines (impact wrenches), Chrome-Vanadium special steel, surface burnished, black





Kraft-Kardangeln Impact Universal Joint



Art.-Nr. / No.				g VE	EUR	7069
7069 00 01	175	890	5	32,00		Für alle elektrisch oder mit Druckluft angetriebenen Maschinenschrauber (Schlagschrauber), Sicherung mit Verbindungsstift und O-Ring, Chrom-Vanadium-Spezialstahl, brüniert / schwarz Suitable for all types of electric and pneumatic screw driving machines (impact wrenches), Chrome-Vanadium special steel, surface burnished, black
7069 00 02	250	1180	5	39,00		
7069 00 03	330	1480	5	49,00		

Kraft-Verlängerungen Impact Extensions



Art.-Nr. / No.					g VE	EUR	7065
7065 00 01	17	50	390	5	16,50		Passend für Außensechskant-Schrauben, mit Sechskant-Profil, nach DIN 3129 / ISO 2725-2, für alle elektrisch oder mit Druckluft angetriebenen Maschinenschrauber (Schlagschrauber), Sicherung mit Verbindungsstift und O-Ring, Chrom-Vanadium-Spezialstahl, brüniert / schwarz For heavy duty applications, for outside hexagon screws, 6-pt., according to DIN 3129 / ISO 2725-2, suitable for all types of electric and pneumatic screw driving machines (impact wrenches), Chrome-Vanadium special steel, surface burnished, black
7065 00 22	18	50	390	5	16,50		
7065 00 02	19	50	390	5	16,50		
7065 00 03	22	50	395	5	17,10		
7065 00 04	24	52	400	5	17,10		
7065 00 05	27	54	400	5	17,10		
7065 00 06	30	54	450	5	17,10		
7065 00 07	32	56	500	5	19,50		
7065 00 21	33	56	500	5	19,50		
7065 00 08	36	56	530	5	20,10		
7065 00 09	41	58	615	5	21,50		
7065 00 20	42	58	615	5	24,20		
7065 00 10	46	63	750	5	26,50		

Kraft-Steckschlüssel-Einsätze Impact Sockets



Steckschlüssel
Socket Sets

Kraft-Steckschlüssel / Impact Sockets

Kraft-Steckschlüssel-Einsätze Impact Sockets, long type

3/4"



SK-Profil



7066

Lange Ausführung, passend für Außensechskant-Schrauben, mit Sechskant-Profil, für alle elektrisch oder mit Druckluft angetriebenen Maschinenschrauber (Schlagschrauber), Sicherung mit Verbindungsstift und O-Ring, Chrom-Vanadium-Spezialstahl, brüniert / schwarz

Long type, for heavy duty applications, for outside hexagon screws, 6-pt., suitable for all types of electric and pneumatic screw driving machines (impact wrenches), Chrome-Vanadium special steel, surface burnished, black

Art.-Nr. / No.	mm	mm	g	VE	EUR
7066 00 07	17	95	626	5	24,10
7066 00 08	19	95	662	5	24,10
7066 00 01	22	95	670	5	24,10
7066 00 02	24	95	690	5	24,10
7066 00 03	27	95	760	5	24,50
7066 00 04	30	95	830	5	27,60
7066 00 05	32	95	870	5	28,10
7066 00 15	33	95	870	5	31,10
7066 00 06	36	95	980	5	34,30
7066 00 09	41	95	1120	5	36,50
7066 00 10	46	95	1440	5	45,20

3/4"-Satz Kraft-Einsätze, 17-tlg. 3/4" Impact Socket Set, 17-pcs.

3/4"



7066

Satz mit den gängigsten 3/4"-Kraft-Steckschlüssel-einsätzen, kurze und lange Form; für alle elektrisch oder mit Druckluft angetriebenen Maschinenschrauber (Schlagschrauber), mit Verbindungsstiften und O-Ringen, Chrom-Vanadium-Spezialstahl, brüniert / schwarz, im stabilen Metallkasten

Tool Set with the most popular 3/4" impact sockets, short and long type, suitable for all types of electric and pneumatic screw driving machines (impact wrenches), with impact retaining rings and pins, Chrome-Vanadium special steel, surface burnished, black, in metal case

Art.-Nr. / No.	g	VE	EUR
7066 00 40	17-tlg. / pcs.	9000	1 369,00
7099	Stift/Ring Pin/Ring	1x 17-33mm	
7065	Kurze Ausführung / Short type: 17; 19; 22; 24; 27; 30; 32mm		
7066	Lange Ausführung / Long type: 17; 19; 22; 24; 27; 30; 32; 33mm		

Kraft-Einsätze, extra lang Impact Sockets, long type

3/4"

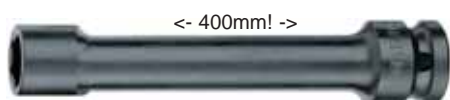

7066/1

Besonders lange Ausführung, z.B. für tiefliegende Radschrauben/Muttern an Nfz, mit Sechskant-Profil, für alle elektrisch oder mit Druckluft angetriebenen Maschinenschrauber (Schlagschrauber), Sicherung mit Verbindungsstift und O-Ring, Chrom-Vanadium-Spezialstahl, brüniert / schwarz

Long type, e.g. for deeply located wheel nuts/bolts on trucks, 6-pt., suitable for all types of electric and pneumatic screw driving machines (impact wrenches), Chrome-Vanadium special steel, surface burnished, black

Art.-Nr. / No.	mm	mm	g	VE	EUR
7066 01 01	24	400	800	1	59,50
7066 01 02	27	400	850	1	59,50
7066 01 03	30	400	920	1	59,50
7066 01 04	32	400	980	1	62,30
7066 01 05	33	400	1100	1	62,30
7066 01 06	36	400	1200	1	65,10



Kraft-Einsätze, Innensechskant Impact Sockets, inside hexagon

3/4"



7080

Passend für Innensechskant-Schrauben (DIN 7426 / ISO 3109), für alle elektrisch oder mit Druckluft angetriebenen Maschinenschrauber (Schlagschrauber), Sicherung mit Verbindungsstift und O-Ring, Chrom-Vanadium-Spezialstahl, brüniert / schwarz

For heavy duty applications, for inside hexagon screws (DIN 7426 / ISO 3109), suitable for all types of electric and pneumatic screw driving machines (impact wrenches), Chrome-Vanadium special steel, surface burnished, black

Art.-Nr. / No.	mm	mm	g	VE	EUR
7080 00 01	10	100	120	5	13,00
7080 00 03	12	100	130	5	13,00
7080 00 05	14	100	150	5	14,25
7080 00 07	17	100	175	5	14,25
7080 00 08	19	100	200	5	14,25
7080 00 10	22	100	200	5	17,10
7080 00 12	24	100	200	5	17,10
7080 00 14	27	100	200	5	17,90

Art.-Nr. / No.	TX		g	VE	EUR	7081
	mm					
7081 00 01	TX 55	70	150	1	26,50	<p>Speziell für Nfz, passend für Außen-TORX-Schrauben, für alle elektrisch oder mit Druckluft angetriebenen Maschinenschrauber (Schlagschrauber)</p> <p>Especialmente para camiones, para tornillos TORX externos, adecuados para todos los tipos de máquinas accionadas eléctricamente y neumáticamente (llaves de impacto)</p> <p>Zum Beispiel / e.g. TX 55: Renault Magnum TX 60: Actros TX 70: Ford, DAF, MAN, Daimler Benz TX 80: Iveco, MAN TGA TX 100: Iveco, MAN TGA</p>
7081 00 02	TX 60	70	200	1	29,30	
7081 00 03	TX 70	70	230	1	29,30	
7081 00 04	TX 80	70	290	1	32,70	
7081 00 05	TX 90	70	350	1	34,80	
7081 00 06	TX 100	70	400	1	35,20	

Kraft-Einsätze, TORX Impact Sockets, TORX



Art.-Nr. / No.	E		g	VE	EUR	7082
	mm					
7082 00 01	18	75	150	1	22,50	<p>Speziell für Nfz, z. B. zum Lösen und Anziehen von Zylinderkopfschrauben; E 18 für MAN M-Reihe; E 20 für MAN F-Reihe; Chrom-Vanadium-Spezialstahl, brüniert / schwarz</p> <p>For trucks, e. g. for cylinder head bolts; E 18 for MAN M-types; E 20 for MAN F-types; Chrome-Vanadium special steel, surface burnished, black</p>
7082 00 02	20	120	240	1	22,50	

Kraft-Einsätze, TORX Impact Sockets, TORX



Art.-Nr. / No.	mm	g	VE	EUR	7083	
7083 00 01	M14	120	150	1	25,00	<p>Speziell für Nfz, z. B. XZN M 17 zum Lösen und Anziehen von Zylinderkopfschrauben (DB-Motoren 400, 420, 500; MB-Nr. 422 589 01 0900) und XZN M 19 für Schwungscheiben bei MB (DB-Motoren 300, 400, 900; MB-Nr. 422 589 02 0900), Chrom-Vanadium-Spezialstahl, brüniert / schwarz</p> <p>For trucks, e. g. XZN M 17 for cylinder head bolts (Mercedes Benz engines 400, 420, 500; MB-No. 422 589 01 0900) and XZN M 19 for balance wheel and vibration shock (Mercedes Benz engines 300, 400, 900; MB-No. 422 589 02 0900); Chrome-Vanadium special steel, surface burnished, black</p>
7083 00 02	M16	120	175	1	27,10	
7083 00 03	M17	120	220	1	28,50	
7083 00 04	M19	120	250	1	29,30	

Kraft-Einsätze, B&S-XZN Impact Sockets, B&S XZN



Art.-Nr. / No.	g	VE	EUR	7072		
7072 00 01	1"	3/4"	50	10	39,50	<p>Für alle elektrisch oder mit Druckluft angetriebenen Maschinenschrauber (Schlagschrauber), Sicherung mit Verbindungsstift und O-Ring, Chrom-Vanadium-Spezialstahl, brüniert / schwarz</p> <p>Suitable for all types of electric and pneumatic screw driving machines (impact wrenches), Chrome-Vanadium special steel, surface burnished, black</p>

Kraft-Verbindungsstück Impact Socket Converter



Kraft-Steckschlüssel / Impact Sockets

Kraft-Kardangelnk Impact Universal Joint

□ 1"



7073

Für alle elektrisch oder mit Druckluft angetriebenen Maschinenschrauber (Schlagschrauber), Sicherung mit Verbindungsstift und O-Ring, Chrom-Vanadium-Spezialstahl, brüniert / schwarz

Suitable for all types of electric and pneumatic screw driving machines (impact wrenches), Chrome-Vanadium special steel, surface burnished, black

Art.-Nr. / No.	↔ mm	⚖ g	📦 VE	EUR
----------------	---------	--------	---------	-----

7073 00 01	140	1400	1	59,80
------------	-----	------	---	-------

Kraft-Verlängerung Impact Extension

□ 1"



7074

Für alle elektrisch oder mit Druckluft angetriebenen Maschinenschrauber (Schlagschrauber), Sicherung mit Verbindungsstift und O-Ring, Chrom-Vanadium-Spezialstahl, brüniert / schwarz

Suitable for all types of electric and pneumatic screw driving machines (impact wrenches), Chrome-Vanadium special steel, surface burnished, black

Art.-Nr. / No.	↔ mm	⚖ g	📦 VE	EUR
----------------	---------	--------	---------	-----

7074 00 01	175	1500	1	54,00
7074 00 02	250	2000	1	65,00
7074 00 03	330	2550	1	75,00

Kraft-Steckschlüssel-Einsätze Impact Sockets

□ 1"



7070

Passend für Außensechskant-Schrauben, mit Sechskant-Profil, nach DIN 3129 / ISO 2725-2, für alle elektrisch oder mit Druckluft angetriebenen Maschinenschrauber (Schlagschrauber), Sicherung mit Verbindungsstift und O-Ring, Chrom-Vanadium-Spezialstahl, brüniert / schwarz

For heavy duty applications, for outside hexagon screws, 6-pt., according to DIN 3129 / ISO 2725-2, suitable for all types of electric and pneumatic screw driving machines (impact wrenches), Chrome-Vanadium special steel, surface burnished, black

Art.-Nr. / No.	⊘ mm	↔ mm	⚖ g	📦 VE	EUR
----------------	---------	---------	--------	---------	-----

7070 00 01	19	58	675	5	27,30
7070 00 02	22	58	675	5	27,30
7070 00 03	24	58	678	5	27,30
7070 00 04	27	60	680	5	27,30
7070 00 05	30	60	680	5	29,00
7070 00 06	32	60	680	5	29,00
7070 00 16	33	60	680	5	29,00
7070 00 07	36	65	780	5	29,20
7070 00 08	38	65	780	5	32,50
7070 00 09	41	67	920	5	35,10
7070 00 10	46	74	1090	1	36,20
7070 00 11	50	80	1245	1	39,20
7070 00 12	55	84	1700	1	52,10
7070 00 13	60	84	1800	1	62,00
7070 00 14	65	87	1940	1	79,30
7070 00 15	70	90	2280	1	85,90

Kraft-Steckschlüssel-Einsätze Impact Sockets, long type

□ 1"





7071

Lange Ausführung, passend für Außensechskant-Schrauben, mit Sechskant-Profil, für alle elektrisch oder mit Druckluft angetriebenen Maschinenschrauber (Schlagschrauber), Sicherung mit Verbindungsstift und O-Ring, Chrom-Vanadium-Spezialstahl, brüniert / schwarz

Long type, for heavy duty applications, for outside hexagon screws, 6-pt., suitable for all types of electric and pneumatic screw driving machines (impact wrenches), Chrome-Vanadium special steel, surface burnished, black

Art.-Nr. / No.	⊘ mm	↔ mm	⚖ g	📦 VE	EUR
----------------	---------	---------	--------	---------	-----

7071 00 00	19	100	960	1	36,20
7071 00 01	22	100	960	1	36,20
7071 00 02	24	100	1000	1	36,20
7071 00 03	27	100	1070	1	41,20
7071 00 04	30	100	1130	1	41,20
7071 00 05	32	100	1170	1	41,20
7071 00 11	33	100	1170	1	41,20
7071 00 06	36	100	1270	1	43,10
7071 00 07	41	100	1430	1	47,50
7071 00 08	46	100	1570	1	52,70
7071 00 09	50	100	1700	1	55,10
7071 00 10	55	100	1700	1	65,30

Art.-Nr. / No.		g VE		EUR	7090
7090 00 01	17-tlg. / pcs.	8900	1	278,00	
3/4"	2x	Verbindungsstück Socket Converter			
1"	2x	Verbindungsstück Socket Converter			
	Bit	1x	17, 19, 22, 24mm		
	Bit	1x	TX 60, TX 70, TX 80; TX 90; TX 100		
	Bit	1x	E 18, E 20; E 22; E 24		



Für alle wichtigen Einsatzbereiche beim Lkw, z. B. Lösen und Anziehen von Zylinderkopfschrauben; für Schwungscheiben usw., Sicherung der Bits durch Innensechskantschraube (Stiftschlüssel im Satz enthalten) - schnelles Wechseln möglich; mit je 2 Adaptern in 3/4" und 1" (!); Chrom-Vanadium-Spezialstahl, brüniert / schwarz, in stabilem Metallkasten

For all main truck applications, e. g. cylinder head bolts, balance wheels and vibration shocks, etc.; with easy change replaceable bits (bits are fixed by a screw and are exchangeable), allen key included, with each 2 connectors in 3/4" and 1" (!); Chrome-Vanadium special steel, surface burnished, black, in metal case



LKW-Satz, Spezial-Kraft-Einsätze

Special Set for Trucks, Impact Sockets

  3/4"



Mit auswechselbaren Bits
Set Screw for Bit Replacement



Art.-Nr. / No.	"	mm	g	VE	EUR	7099
Ringe / Rings						
7099 00 03	1/2	10 - 14	1	10	0,70	
7099 00 04	1/2	15 - 30	2	10	0,80	
7099 00 13	3/4	alle / all	3	10	1,30	
7099 00 14	1	alle / all	8	10	1,90	
Stifte / Pins						
7099 00 05	1/2	10 - 14	1	10	0,35	
7099 00 06	1/2	15 - 30	2	10	0,35	
7099 00 07	3/4	alle / all	4	10	0,70	
7099 00 08	1	alle / all	7	10	0,70	

Passend für Kraft-Steckschlüssel-Einsätze, nach DIN 3129 / ISO 2725-2, für alle elektrisch oder mit Druckluft angetriebenen Maschinenschrauber (Schlag-schrauber)

Suitable for impact sockets, according to DIN 3129 / ISO 2725-2, suitable for all types of electric and pneumatic screw driving machines (impact wrenches)

Sicherungs-Gummiringe und -Stifte sind nicht im Lieferumfang der Kraft-Steckschlüssel-Einsätze enthalten! Bitte gesondert bestellen.
Retaining rings and retaining pins are not included in impact sockets or impact accessories! Please order separately.

Kraft-Sicherungsringe u. -stifte

Impact Retaining Pins and Rings

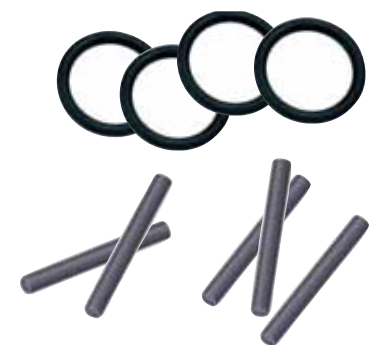

Kfz-Spezialwerkzeuge	Seite Page	Automotive Tools
Karosserie	170-177	Car Body
Scheiben	178-179	Windscreen
Bremsen	180-184	Brakes
Räder	185-187	Wheels
Fahrwerk	188-189	Chassis
Auspuff	190	Exhaust System
Lambda-Sonden	191	Lambda Probes
Schlauchklemmen	192-193	Hose Clamps
Batterie	194	Battery
Kühlsystem	195	Cooling System
Fahrzeugelektronik	196-200	Electricity
Motor / Motorsteuerung	201-207	Engine / Timing Tools
Ventile	208	Valves
Öldienst	209-211	Oil Service
Zünd- und Glühkerzen	213-215	Spark and Glow Plugs
Düsen / Einspritzleitungen	216-217	Injection Nozzles and Pipes
Spezialwerkzeuge für Nutzfahrzeuge	218-220	Special Tools for Trucks



Inhalt Index



Kfz-Spezialwerkzeuge
Automotive Tools

Karosserie / Scheiben Car Body / Windscreen



Türbolzen-Ausziehgerät Impact Puller for door hinge bushes



242/243

Schlag-Ausziehbügel, schwere Ausführung, zum sicheren Ein- und Ausbau von Kfz-Türbolzen; zum Austreiben von Spannhülsen der Türscharniere; Oberfläche verzinkt, mit Ausziehbolzen

Impact Puller for removing door hinge bushes; special steel, surface galvanized, with extraction pin

Für / For:
VW / AUDI, OPEL, PEUGEOT, RENAULT etc.

Art.-Nr. / No.	mm	mm	g	VE	EUR
----------------	----	----	---	----	-----

0243 00 02	2-tlg. / pcs.		840	1	19,50
------------	---------------	--	-----	---	-------

Schlag-Ausziehbügel / Impact Puller					
0243 00 01		16 360	800	1	18,50

Ausziehbolzen / Extraction Pin					
0242 00 01		5 100	40	10	2,10

Türscharnier-Einsteckwerkzeug Insert Door Hinge Wrench



244

Zum drehmomentkontrollierten Ein- und Ausbau von Türen sowie zur Türeinrichtung, mit Spezial-Bit, mit 9x12mm Vierkantaufnahme für Drehmomentschlüssel 6185 oder Einsteck-Griff 6184, Chrom-Vanadium-Stahl 31 CrV 3, matt verchromt

For torque controlled installing and removing of the doors and for door alignment; with plug -and-socket-connection 9x12mm to accommodate insert tools, can be used with MATADOR 6185 and 6184; Chrome-Vanadium-Steel 31 CrV 3 (1.2208), chrome finish

Für / For:
VW / AUDI, MERCEDES BENZ etc.

Art.-Nr. / No.	mm	g	VE	EUR
----------------	----	---	----	-----

0244 00 05	TX 45	95	100	1	19,80
0244 00 06	XZN 10	95	100	1	19,80

Ersatzhalter / Spare door hinch					
0244 00 95		95	100	1	17,80

Ersatzbits / Spare bits					
0245 00 11	TX 45		10	1	3,50
0245 00 14	XZN 10		10	1	3,50

Türscharnier-Knarrensatz, 6-tlg. Door Hinge Ratchet Set, 6 pcs



245

Spezial-Satz für Türscharnierarbeiten, besonders für schwer zugängliche Schrauben, mit Umschaltknarre für Bits (240mm) und den wichtigsten Spezial-Bits (5/16") in TX 40 / TX 45; XZN 5 / 8 / 10, in Tasche

Special reversible ratchet (240mm) to reach narrow spaces while working on door hinges, contains the most important bits (5/16") in TX40 / TX 45, XZN 5 / 8 / 10; carefully selected

Für / For:
VW / AUDI, MERCEDES BENZ, PORSCHE etc.

Art.-Nr. / No.	g	VE	EUR
----------------	---	----	-----

0245 00 01	6-tlg. / pcs.	600	1	39,95
------------	---------------	-----	---	-------





Ersatzknarre / Spare ratchet				
0245 00 02		590	1	29,95

Ersatzbits / Spare bits					
0245 00 10	TX 40		10	1	3,50
0245 00 11	TX 45		10	1	3,50
0245 00 12	XZN 5		10	1	3,50
0245 00 13	XZN 8		10	1	3,50
0245 00 14	XZN 10		10	1	3,50

Art.-Nr. / No.	 mm	 mm	 g	 VE	EUR	246
0246 00 01	15	150	90	1	9,95	<p>Zum Einstellen der vorderen und hinteren Türen, extra schmal, durch Ringprofil höhere Drehmomentwerte, mit Aufhängeloch, Chrom-Vanadium-Stahl 31 CrV 3, matt verchromt</p> <p>For adjusting of the front and back doors, very slim design, ring profile for better torque transmission, with hole, Chrome-Vanadium-Steel 31 CrV 3 (1.2208), matt chrome finish</p> <p>Für / For: VW (Golf 2004-, Golf Plus 2005-, Jetta 2005-)</p>

Spezial-Türeinsteckschlüssel Special Door Adjusting Wrench





Art.-Nr. / No.	 mm	 "	 g	 VE	EUR	546
0546 00 01	200	8	75	5	19,80	<p>Zum Entfernen von Tür- und Fensterfedern, Griffe aus geprägtem Stahlblech, Zangenmaul aus Spezialstahl, gehärtet, brüniert, vernickelt</p> <p>For the removal and application of Omega-retaining rings at door and window handles, e. g. at BMW, Ford, Opel, VW/Audi etc., nickle plated</p>



Türfederzange Door Spring Pliers



Art.-Nr. / No.	 mm	 g	 VE	EUR	549
0549 00 01	230	180	1	34,90	<p>Lösezange, zum beschädigungsfreien Lösen von Befestigungsstopfen an Türverkleidungen, Zierleisten, Schmutzfängern etc., Spezialstahl, vernickelt</p> <p>For removing fixing bolts on door panels, mouldings and bumper rubber strips, special steel</p> <p>Für / For: VW / AUDI / MERCEDES BENZ etc.</p>

Türverkleidungs-Lösezange Pliers for door panels



Art.-Nr. / No.	 mm	 g	 VE	EUR	587/4
0587 00 04	240	410	1	42,75	<p>Für Arbeiten an besonders schwer zugänglichen Stellen, z. B. Anpassen von Türen, Heckklappen und Motorhauben, ohne die Zange zu entfernen, Einhandbedienung, Schnell-Lösehebel, hält zwei überlappende Bleche; Spezialstahl, glanzvernickelt / Backen brüniert</p> <p>For gripping two lap joints, when fitting motorcar parts the adjustment of doors, tailgates and engine bonnets can be completed without removing the pliers; high grade tool steel, nickel plated / jaws black finish</p>



Axial-Gripzange Axial Grip Pliers



Axial-Gripzange
Axial Grip Pliers



587/5

Zum Fixieren von Karosseriefalzen und U-Profilen, insbesondere zum Anpassen von Türschweller, Radläufen und Dächern, Punktschweißen zwischen den Zangenbacken leicht möglich, axial verlaufende Spannkraft für Arbeiten an engen Stellen; Spezialstahl, glanzvernickelt / Backen brüniert

Clamps two butt or adjacent joints, special head and linear motion allow use for many shapes even in awkward sections; perfect for auto body repair and welding work, single hand push-button release; high grade tool steel, nickel plated / jaws black finish

Art.-Nr. / No.	mm	g	VE	EUR
0587 00 05	220	450	1	35,00
Spannweite capacity:	0-15			
Ausladung jaw width:	9			



Axial-Gripzange
Axial Grip Pliers



587/6

Zum rechtwinkligen Greifen von zwei Blechen mit gleicher Stärke, axial verlaufende Spannkraft für Arbeiten an engen Stellen; Spezialstahl, glanzvernickelt / Backen brüniert

Clamps two sheet metal pieces of equal thickness at 90°, special head and linear motion allow use for many shapes even in awkward sections; perfect for auto body repair and welding work; single hand push-button release, high grade tool steel, nickel plated / jaws black finish

Art.-Nr. / No.	mm	g	VE	EUR
0587 00 06	200	460	1	45,00
Spannweite capacity:	0-10			
Ausladung jaw width:	15			



Axial-Gripzange
Axial Grip Pliers



587/7

Zum Greifen von zwei überlappenden oder anliegenden Blechen mit Falzen, axial verlaufende Spannkraft für Arbeiten an engen Stellen; Spezialstahl, glanzvernickelt / Backen brüniert

Clamps two flanged lap joints, special head and linear motion allow use for many shapes even in awkward sections; perfect for auto body repair and welding work, single hand push-button release; high grade tool steel, nickel plated / jaws black finish

Art.-Nr. / No.	mm	g	VE	EUR
0587 00 07	210	425	1	38,00
Spannweite capacity:	0-15			
Ausladung jaw width:	7			



Axial-Gripzange
Axial Grip Pliers



587/8

Zum Greifen von zwei überlappenden oder anliegenden Blechen mit Falzen, axial verlaufende Spannkraft für Arbeiten an engen Stellen; Spezialstahl, glanzvernickelt / Backen brüniert





Clamps two flanged, lapped or adjacent joints, special head and linear motion allow use for many shapes even in awkward sections; perfect for auto body repair and welding work, single hand push-button release; high grade tool steel, nickel plated / jaws black finish



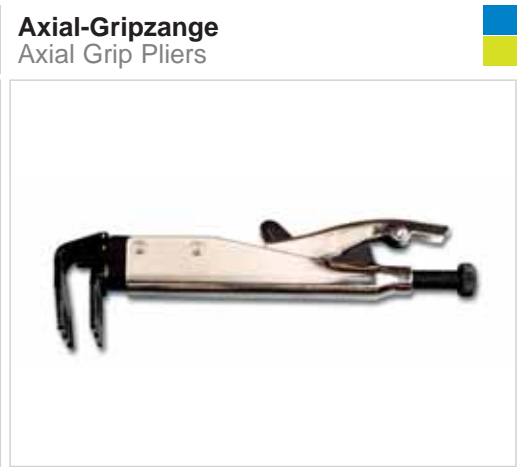

Art.-Nr. / No.	mm	g	VE	EUR
0587 00 08	235	500	1	39,00
Spannweite capacity:	0-15			
Ausladung jaw width:	25			



Art.-Nr. / No.	mm	g	VE	EUR	
0587 00 09	195	475	1	45,00	<p>589/9 Axial-Gripzange Axial Grip Pliers</p> <p>Zum Greifen überlappender Bleche, ermöglicht 4 Schweißpunkte ohne Entfernen der Zange, axial verlaufende Spannkraft für Arbeiten an engen Stellen; Spezialstahl, glanzvernickelt / Backen brüniert</p> <p>Clamps lap joints allowing 4 consecutive spot welds without tool removal, special head and linear motion allow use for many shapes even in awkward sections; perfect for auto body repair and welding work; single hand push-button release, high grade tool steel, nickel plated / jaws black finish</p>
Spannweite capacity:	0-15				
Ausladung jaw width:	36				



Art.-Nr. / No.	mm	g	VE	EUR	
<p>732 Ausbeulwerkzeuge Body and Fender Tools</p> <p>Geschmiedete Ausbeulwerkzeuge, blau lackiert, mit geschliffenen oder karierten Arbeitsflächen, aus Vergütungsstahl C 45 (W 1.0503), Stiel aus Eschenholz</p> <p>Heat-treated steel according to DIN 17200 (1.0503), blue coated, with ash handle, with ground and milled faces</p>					
0732 00 01	165 x 28	680	1	38,50	<p>0732 00 01</p> 
0732 00 03	135 x 35	350	1	46,50	
0732 00 04	160 x 40	450	1	48,50	<p>0732 00 04</p> 
0732 00 06	100 x 32 x 25	300	1	38,50	
0732 00 07	96 x 40 x 35	380	1	58,50	<p>0732 00 07</p> 
0732 00 08	155 x 40 x 30	430	1	44,20	
Ersatzstiel / Spare handle	300	60	1	5,90	<p>0732 00 08</p> 
0732 10 30					

Art.-Nr. / No.	mm	g	VE	EUR	
<p>734 Universal-Handfäuste Universal Hand Anvils</p> <p>Geschmiedete Handfäuste, blau lackiert, mit geschliffenen oder karierten Arbeitsflächen, aus Vergütungsstahl C 45 (W 1.0503)</p> <p>Forged Hand Anvils, blue laquered, with ground or milled faces, made of heat-treated C 45 steel (W 1.0503)</p>					
0734 00 02					<p>0734 00 02</p> 
0734 00 05					
0734 00 06					<p>0734 00 06</p> 
0734 00 07					
0734 00 08					<p>0734 00 08</p> 
0734 00 10					
0734 00 11					<p>0734 00 11</p> 
0734 00 14					
0734 00 15					<p>0734 00 15</p> 
0734 00 17					



Löffel- und Biegeeisen Body and FenderSpoons

735

0735 00 01



0735 00 02



Geschmiedete Ausführung, blau lackiert, mit geschliffenen Arbeitsflächen, aus Vergütungsstahl C 45 (W1.0503)

Forged Body and Fender Spoons, blue laquered, with ground faces, made of heat-treated C 45 steel (W 1.0503)

0735 00 03



0735 00 04



Art.-Nr. / No.	mm	g	VE	EUR
0735 00 01	400 x 25 x 58	1000	1	41,00
0735 00 02	440 x 58 x 150	1900	1	91,00
0735 00 03	500 x 58	2200	1	98,00
0735 00 04	270 x 30 x 18	550	1	43,00
0735 00 05	300 x 50	850	1	55,00
0735 00 06	390 x 25 x 58	950	1	79,00

0735 00 05



0735 00 06



Ausbeulwerkzeug-Satz, 7-tlg. Body and Fender Tool Set, 7 pcs

736/1



Satz mit den wichtigsten Ausbeulwerkzeugen, Made in Germany, im stabilen Metallkasten

Set with the most important body and fender tools, professional high quality tools, Made in Germany, in metal case

Inhalt / contents:

- Ausbeulhammer / Bumping Hammers
- Kunststoff-Treib- und Ausbeulhammer / Plastic Hammer
- Handambosse / Hand anvils

Art.-Nr. / No.	g	VE	EUR
0736 00 01	7-tlg. / pcs.	8500	1 210,00

Ausbeulwerkzeug-Satz, 9-tlg. Body and Fender Tool Set, 9 pcs

736/2



Satz mit den wichtigsten Ausbeulwerkzeugen, Made in Germany, im stabilen Metallkasten

Set with the most important body and fender tools, professional high quality tools, Made in Germany, in metal case

Inhalt / contents:

- Ausbeulhammer / Bumping Hammers
- Handambosse / Hand anvils
- Biegeeisen / Bending iron
- Kunststoff-Treib- und Ausbeulhammer / Plastic Hammer

Art.-Nr. / No.	g	VE	EUR
0736 00 02	9-tlg. / pcs.	11500	1 358,00

Art.-Nr. / No.	mm	g	VE	EUR	
					740
0740 00 01	350	820	1	49,00	<p>Verstellbar, mit Spannschraube, mit Feile (grob / Hieb 1, radial verzahnt), Spezialstahl</p> <p>Adjustable, with tightening screw, with file (coarse / cut 1, radial cut), special steel</p>
0740 00 02	350	560	1	25,00	<p>Karosserie-Feilenhalter, verstellbar, mit Spannschraube, ohne Feile, Spezialstahl</p> <p>Body work file holder, adjustable, with tightening screw, without file, special steel</p>
0740 00 03	350	260	1	25,50	<p>Grob / Hieb 1, radial verzahnt, DIN 7264 Form A Coarse / cut 1, radial cut, DIN 7264 Form A</p>
0740 00 05	350	260	1	22,50	<p>Grob / Hieb 1, schräg verzahnt, DIN 7264 Form A Coarse / cut 1, diagonal cut, DIN 7264 Form A</p>
0740 00 06	350	260	1	25,50	<p>Halbrund (hohl) / Hieb 1, radial verzahnt, Form F Half-round (hollow) / cut 1, radial cut, Form F</p>

Karosserie-Feilenhalter Body Work File Holder



Art.-Nr. / No.	mm	g	VE	EUR	
					741
0741 00 01	280	1200	1	119,00	<p>Kombiniertes Absetzlochwerkzeug zum Absetzen und Lochen von Blechen bis 1mm Stärke; Handhabung ohne Kraftaufwand - Einhandbedienung -, gehärtete Absetzbacken; Absetztiefe 13mm; Backenbreite 22mm</p> <p>Labor saving tool, crimps edges on sheet metals up to 1mm thickness, crimping capacity 13mm, with rotating head, allows to punch holes in panels also, one hand usage, width 22mm</p>

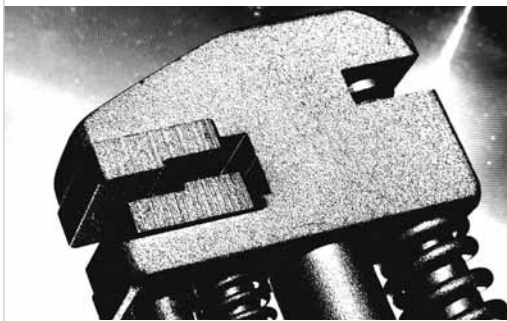

Loch- und Absetzzeuge Punch and Flange Tool



Art.-Nr. / No.	mm	"	g	VE	EUR	
						745 / 746
0745 00 02	250	10	550	1	22,50	<p>Schneide gehärtet, mit Feder, lackiert, Schenkel tauchisoliert, rechtsschneidend</p> <p>Hardened shear head, lacquered, right hand cutting</p>
<p>Schneidleistung / cutting capacity: Aluminium / stainless metal sheets: 1,2mm Bleche / metal sheets: 1,8mm</p>						
0746 00 01	260	10.1/4	460	1	28,50	<p>Blechknabber, für runde und rechteckige Ausschnitte, ermöglicht bei leichter Handhabung saubere Schnitte mit gratfreien Kanten ohne Verformung</p> <p>Tin Snips, materials are cut without deformation, clean cut edges - no additional work needed on the cut profile, easy handling</p>
<p>Schneidleistung / cutting capacity: Aluminium / stainless metal sheets: 1,2mm Bleche / metal sheets: 2,0mm</p>						
<p>Ersatzmesser / Spare blade</p>						
0746 00 02			10	1	6,50	

Lochblechscherer / Blechknabber Hole Cutting Snips / Tin Snips



Universal-Hebelblehschere Universal Lever Tin Snips



747

Für Figuren und kurze, gerade Schnitte, große Radien, mit verschraubtem Gesenk und Hebelübersetzung, Griffe mit Kunststoff-Überzug, Scherenkopf im Gesenk geschmiedet, Schneiden auf HRC 60-62° gehärtet, Spezialstahl

For figure cutting and short, straight cuts, large radius, with lever transmission system, handles with plastic cover, shear head drop forged, temper of cutting edges HRC 60-62, special steel

Schneidleistung / cutting capacity:
Aluminium / highgrade steel: 1,2mm
Bleche / sheet steel: 1,8mm

Art.-Nr. / No.	mm	"	g	VE	EUR
----------------	----	---	---	----	-----

0747 00 01 (R)	250	9.3/4	515	1	35,00
0747 00 02 (L)	250	9.3/4	515	1	35,00

R = rechtsschneidend / right hand cutting
L = linksschneidend / left hand cutting



- Gratfreier Schnitt
- microverzahnte Klinge verhindert Abgleiten beim Schnitt
- Cut without any burr
- Micro serrated cutting edges prevent slipping off while cutting

Ideal-Durchlaufschere Figure Lever Tin Snips



748

Für Figuren und kurze, gerade Schnitte, enge Radien, mit verschraubtem Gesenk und Hebelübersetzung, Griffe mit Kunststoff-Überzug, Scherenkopf im Gesenk geschmiedet, Schneiden auf HRC 60-62° gehärtet, Spezialstahl

For figure cutting and short, straight cuts, small radius, with lever transmission system, handles with plastic cover, shear head drop forged, temper of cutting edges HRC 60-62, special steel

Schneidleistung / cutting capacity:
Aluminium / highgrade steel: 1,2mm
Bleche / sheet steel: 1,8mm

Art.-Nr. / No.	mm	"	g	VE	EUR
----------------	----	---	---	----	-----

0748 00 01	250	10	470	1	35,00
------------	-----	----	-----	---	-------



- Gratfreier Schnitt
- microverzahnte Klinge verhindert Abgleiten beim Schnitt
- Cut without any burr
- Micro serrated cutting edges prevent slipping off while cutting

Karosserie-Blechmeißel Car Body Chisel



846

Zum Trennen von Blechen, Schweißpunkten sowie Schweißfugen, mit Handschutz, Klinge 7x26mm, Lufthärtestahl, Schlagkopf vergütet, lackiert, Schneide geschliffen

For cutting sheet metal, welding spots, welding grooves etc., with hand guard, blade size 7x26mm, self hardening steel, lacquered

Art.-Nr. / No.	mm	g	VE	EUR
----------------	----	---	----	-----

0846 00 01	240	150	1	16,20
------------	-----	-----	---	-------



Mit Handschutz
With hand guard

Schweißpunktfräser / -bohrer Welding Spot Cutter



860 / 862

Schweißpunktfräser, Krone aus HSS, schwarz, mit 7mm Sechskantschaft und auswechselbarer Fräskrone, zum Ausräsen von Karosserieteilen

Welding Spot Cutter, cutting crown HSS, black, with 7mm hexagon shank and changeable cutting crown, for welding spot reaming of car bodies

Schweißpunktbohrer, extra stabile Konstruktion, gratfreies Bohren ohne Ankrömen; für alle Bleche

Extra stable special drill, extreme high precision, for sheet steel, brass, aluminium, zinc, copper, plastic sheets etc.

Art.-Nr. / No.	mm	mm	g	VE	EUR
----------------	----	----	---	----	-----

0860 00 01	10	72	23	5	14,50
------------	----	----	----	---	-------

Ersatzkrone / Milling Crown 0860 00 02				5	6,90
---	--	--	--	---	------

Ersatz-Zentrierstift / Centering Pin 0860 00 03				5	4,00
--	--	--	--	---	------

0862 00 03	6	66	20	10	18,90
------------	---	----	----	----	-------

0862 00 04	8	80	24	10	19,50
------------	---	----	----	----	-------

Details siehe S. 120 /
For details pls. refer to page 120

Art.-Nr. / No.	mm	g	VE	EUR	
0872 00 01	250	670	1	55,00	872 Blindniethandzange Professional Handriveter
Ersatzbacken / Spare jaws 0872 00 90			1	3,50	

Profi-Blindnietzange mit 3 Ersatzbacken, Zangen-gehäuse aus hochwertigem Alu-Druckguss, schmaler Zangenkopf für schwer zugängliche Nietstellen, Öffnungsfeder für selbsttätigen Dornauswurf

Professional riveter, body made of aluminium die casting, slim head design for difficult access areas, opening spring, with 3 spare jaws

Blindnieten-Durchmesser / Blind Rivets diameter:
 Aluminium / highgrade steel: 2,4-4,8mm
 Stahl / steel: 3,0-4,0mm
 Kupfer / copper: 3,0-4,0mm
 Inox / inox: 3,0-4,0mm





Art.-Nr. / No.	mm	g	VE	EUR	
0842 00 01	250	150	1	9,50	842 Türverkleidungs-Lösewerkzeug Tool for door panels

Türverkleidungs-Lösehebel, zum schnellen und einfachen Ausbau der Türverkleidungen, z.B. hintere feststehende Türfensterscheibe mit Fensterführung; Maulöffnung 28mm, Spezialstahl

Lever, for fast and easy removing of mouldings and door panels, can be used for plugs and plastic clips, jaw opening 28mm, special steel

Für / For:
VW/AUDI/SEAT/SKODA etc.





Art.-Nr. / No.	mm	g	VE	EUR	
0843 00 01	160x60	100	1	9,95	843 Montage-Keile Plastic Wedges
0843 00 04	230	50	1	9,95	

Zum schnellen und einfachen Lösen von Blenden, Zierleisten, Innenraumverkleidungen usw., vermeidet Kratzer an Lack und Blech, aus sehr resistentem Kunststoff.

For fast and easy removing of mouldings and door covering, avoids damage of lacquered surfaces

Eine Seite aufgebogen (z. B. zum Lösen von Tür-/Teppich-Verkleidungsstopfen), andere Seite mit flacher Nute zum Eindrücken von Stopfen

One side open / bent (for loosening door / cover clips), one side with flat pin to fix plastic clips





Art.-Nr. / No.	mm	g	VE	EUR	
0843 00 03	250	150	1	14,95	843/3 Montage-Keil mit Filzauflage Plastic Wedge with felt surface

Zum schnellen und einfachen Lösen von Zierleisten und Türverkleidungen, aus sehr resistentem Kunststoff, eine Seite spitz, andere Seite mit Filzauflage zum beschädigungsfreien Aufschlagen von Zier- bzw. Chromleisten

For fast and easy removing of mouldings and door covering, application of plugs and plastic clips, avoids damage of lacquered surfaces, plastic and metal parts; one side pointed, one side with felt surface to fix plastic panels, cross section approx. 20x20mm

Mit Filzauflage für Zierleisten
With felt surface



Scheiben / Windscreen

Spezial-Schraubendreher TX 8 Special Screwdriver TX 8



620

Für Karosserie-Montearbeiten, insbesondere im Innenraum, z.B. Ein- und Ausbau der Verkleidung der Lenksäule, mit Kunststoffheft, schwarze Spitze, Klinge verchromt, Chrom-Vanadium

For low-lying screws in dashboard or car body, esp. for installing and removing the cover of the steering post, with plastic handle, black tip, blade chrome plated, Chrome Vanadium

Für / For:
VW / AUDI / SEAT etc.

Art.-Nr. / No. TX mm mm g VE EUR

0620 09 02 8 155 240 200 1 7,95

5-Stern-Schraubendreher 5-Star Screwdriver T-Handle



630

Spezial-Schraubendreher mit T-Griff, mit 5-Sternprofil (IP 20), z.B. zum Ein- und Ausbau der Außenspiegel bei Mercedes Benz

With T-Handle, for inside 5-star screws with centre pin, e.g. for installing and removing the exterior mirror on Mercedes Benz

Für / For:
MERCEDES BENZ (W203, 211, 2005-) etc.

Art.-Nr. / No. T mm g VE EUR

0630 00 01 20 250 50 10 9,50

Dichtungs- und Glasschaber Scraper for Gasket and Glass



840 / 841

Zum Entfernen von Dichtungsrückständen, besonders lang, Arbeitsflächen geschliffen, mit schlagfestem Kunststoffheft in schwarz

For removal of waste on washers and gaskets, blade ground, with impact resistant plastic handle

Glasschaber aus Metall mit Klingenschutz, mit Kunststoffheft, auswechselbare Klingen, 40mm breit, zum Lösen von Etiketten, Abziehbildern usw.

Glass scraper, metal, very solid, plastic handle, with blade protection, blades exchangeable, blade width 40mm, perfect for cleaning of car windows etc.

Art.-Nr. / No. mm g VE EUR

0840 00 01 250 110 5 12,50

0841 00 01 120 30 5 13,90

Ersatzklinge / Spare blade
0841 00 95 5 10 0,50

Scheiben-Austrennmesser Windscreen Removal Tool



858



Profi-Kaltschneidmesser zum Austrennen von geklebten Autoscheiben, mit stufenlos verstellbarer Klinge (kann an Karosseriehöhe angepasst werden und schützt somit Lack und Gummidichtungen im A-Säulenbereich), mit Zug-Griff, sekundenschneller Wechsel der Klinge, ergonomischer Handgriff

For the extraction of glued windscreens, knife with pulling handle, new lever with quick release handle, avoids the back edge of the knife blade from touching or scratching the body/paintwork due to adjustable height of the blade; ergonomic handle

Art.-Nr. / No. g VE EUR

0858 00 01 120 1 68,50

2 Stück Edelstahl-Ersatzklingen /
2 pcs of spare blades, stainless steel
0858 00 95 19,25mm 5 1 9,95

Art.-Nr. / No.										859
		g	VE	EUR						
0859 60 01	5-tlg. / pcs.	900	1	89,00						
<p>Qualitäts-Vierkantdraht / High grade 4-pt. wire 0858 00 04 0,6mm 50m 400 1 19,90</p>										

5-tlg. Satz, geeignet für alle geklebten Windschutzscheiben sowie die meisten Heck- u. Seitenscheiben, ideal auch bei Fahrzeugen mit tiefem Cockpit

5 pcs set, suitable for all glued windscreens

Inhalt / contents:

- 2 selbstschließende Sicherheits-Zuggriffe für Vierkant-Draht / 2 self-locking wire handles
- Qualitäts-Vierkant-Schneidedraht / 4-pt. wire
- Gegenhalter für Draht / Wire counter holder
- Robuster Drahtstarter mit T-Griff / Wire Feeder Tool

Ausglaswerkzeug-Satz Windscreen Removal Kit





Art.-Nr. / No.										731/300
		g	VE	EUR						
0731 03 00	11-tlg. / pcs.	2200	1	295,00						

11-tlg.-Universal-Satz, zum Abziehen der vorderen und hinteren Scheibenwischer, für ca. 450 verschiedene Wischer, 300 Fahrzeugtypen und 30 Automarken, für Pkw und Nfz, mit Anwendungstabelle, in schwarzem Kunststoffkoffer

11-pcs. universal set, for pulling off windscreen wiper arms and rear window wiper arms, for more than 450 different wiper arms, 300 vehicles and 30 car brands, table of use is inserted, in black plastic case

Scheibenwischerarm-Abzieher-Satz Windscreen Wiper Arm Pulling Set



Art.-Nr. / No.										863
	mm	g	VE	EUR						
0863 00 01	150-650	50	10	7,90						



Teleskopstab mit Neodym-Magnetkopf, Haftkraft 500gr, 6mm Durchmesser, zum Einstellen der Düsen von Scheibenwaschanlagen (zeigt die Strahlrichtung der Düse auf der Scheibe an), mit Hemdenclip, aus Spezialstahl, verzinkt

Telescopic handle with Neodym magnetic head (6mm diameter), capacity 500gr, for adjusting the nozzles of the washing system, can be used to demonstrate the jet direction to the window, adjusting needle and protective cap, with pocket clip, special steel, zinc plated



Düseneinsteller Waschanlage Nozzle Adjusting Tool



Art.-Nr. / No.										864/865
	mm	g	VE	EUR						
0864 00 01	324	663	1	75,00						
0865 00 01	390	751	1	135,00						

Saugheber für diverse Lasten, geeignet für alle Materialien mit planen und gasdichten Oberflächen, mit starren Saugköpfen, Hebekraft max. 60kg

For all kinds of loads, for all materials, firm suction caps, for plain panes, capacity max. 60kg

Für gewölbte Oberflächen, mit beweglichen Saugköpfen; Hebekraft max. 45kg

Suitable for all materials with curved surfaces, capacity max. 45kg

Saugheber Suction Lifters

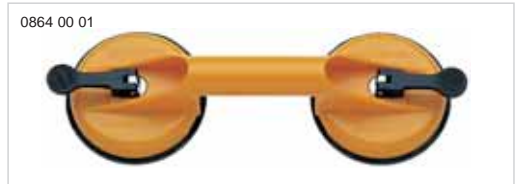

Bremsen / Räder / Fahrwerk

Brakes / Wheels / Chassis



Offene Bremsleitungsschlüssel Flare Nut Wrenches



250

Für Bremsleitungsverschraubungen, verstärkte Ausführung, gerade Form insbesondere für Verschraubungen an der Vorderachse, gekröpfte Form insbesondere zum Erreichen der Verschraubungen am Radbremszylinder vorbei an der umlaufenden Kante der Ankerplatte, für Vorder- und Hinterachse, mit Sechskant und geradem Schlitz, Chrom-Vanadium-Stahl 31 CrV 3, matt verchromt

For screwed connections on brake lines - especially to reach the screws at front and back axle, reinforced design, with 6-pt., Chrome-Vanadium-Steel 31 CrV 3 (1.2208), matt chrome finish

Art.-Nr. / No.	mm	mm	g	VE	EUR
----------------	----	----	---	----	-----

Gerade Form / straight type					
0250 00 01	10 x 11	160	180	10	23,10
0250 00 04	12 x 13	160	105	10	23,10

Gebogene Form / offset type					
0250 00 20	10 x 11	175	75	10	25,50



Bremsen-Entlüftungsschlüssel Brake Bleeding Wrenches

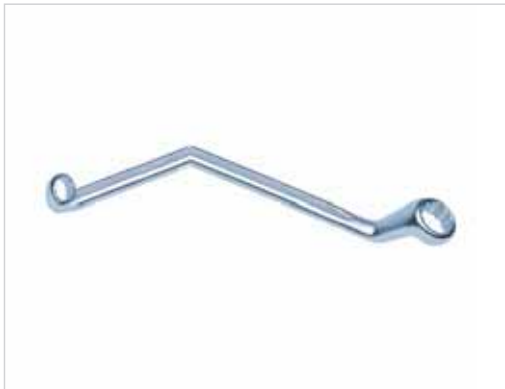

250/30

Normal tief gekröpft und extra tief gekröpft, für Alu- und Stahlfelgen, beidseitig gleiche Schlüsselweite; keine Demontage der Räder notwendig; zur Erneuerung von Radbremszylindern, Hauptbremszylindern, Leitungsanschlüssen etc., Chrom-Vanadium-Stahl 31 CrV 3, matt verchromt

For alu and steel fellies, brake releasing without removing the wheels, for the replacement of wheel brake cylinders, tube connections etc., box ends are offset for access to bleeder fittings, with equal dimensions on both sides; Chrome-Vanadium-Steel 31 CrV 3 (1.2208), matt chrome finish

Art.-Nr. / No.	mm	mm	g	VE	EUR
----------------	----	----	---	----	-----

0250 00 30	7	190	75	5	13,50
0250 00 31	8	208	75	5	13,50
0250 00 32	9	208	75	5	13,50
0250 00 33	10	236	75	5	14,00
0250 00 34	11	236	75	5	14,50

Offener Doppelringschlüssel Flare Nut Ring Spanners



251

Für Rohrverschraubungen, Überwurfmutter und -schrauben, z.B. für Rohrkrümmer an der Flügelpumpe der Lenkung für BMW sowie für Verschraubungen an Einspritzleitungen, Chrom-Vanadium-Stahl 31 CrV 3, matt verchromt

For tube connections, union nuts and male fittings for pipes, e.g. for wingpump manifold of the BMW steering and for all threaded connectors on injector pipes, Chrome-Vanadium-Steel 31 CrV 3 (1.2208), matt chrome finish

Für / For:
MERCEDES BENZ (~MB-Nr. 000 589 0703 00)

Art.-Nr. / No.	mm	mm	g	VE	EUR
----------------	----	----	---	----	-----

0251 00 06	14 x 17	200	145	10	14,20
0251 00 07	17 x 19	210	155	10	16,10

Art.-Nr. / No.	mm	mm	g	VE	EUR	
0255 00 01	10	300	320	1	38,00	255

Universal-Werkzeug, für verschiedene Fahrzeugtypen; Chrom-Vanadium-Stahl 31 CrV 3, matt verchromt

Universal spanner, for various vehicles, Chrome-Vanadium-Steel 31 CrV 3 (1.2208), matt chrome finish

Für / For:
OPEL (Astra G, Vectra B), AUDI (100), MAZDA etc.

Bremseinstellschlüssel

Brake Adjusting Spanner

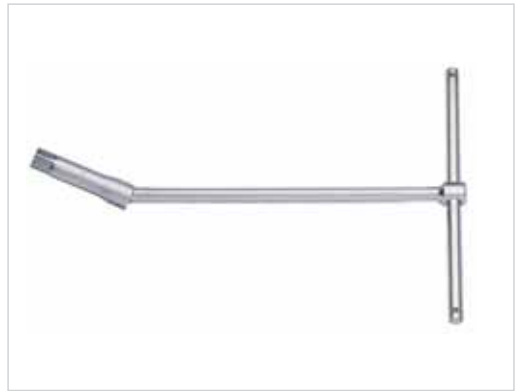

Art.-Nr. / No.	g	VE	EUR	
0570 30 02	950	1	98,00	ModuFlex L 570

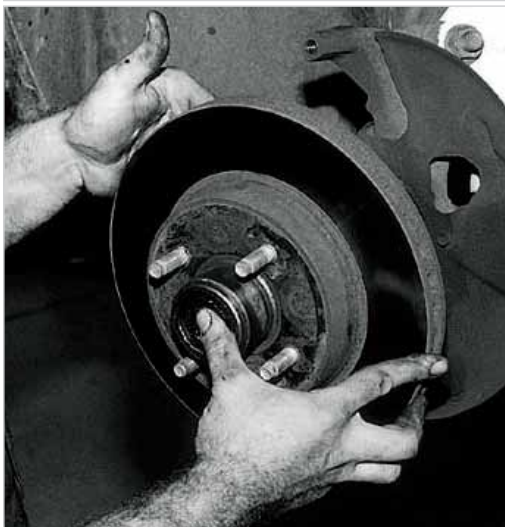
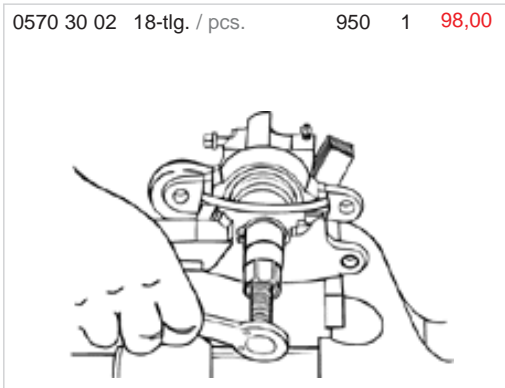

18-tlg. Universal-Satz mit zahlreichen Adaptern, mit zwei Spindeln mit Axiallager (Links- und Rechtsgewinde), für die meisten Fahrzeugtypen einsetzbar; zum Wechseln der Bremsbeläge an Fahrzeugen mit Schwimmsätteln an der Hinterachse. Anwendung: Bremskolben mit Hilfe der Spindel und eines Adapters in Nullstellung bringen und neue Bremsbeläge montieren; Adapter für alle gängigen Fahrzeuge enthalten, inkl. 3/8"-Knarrenadapter, um verschlissene Bremsbeläge zu entfernen. Auch für VW Golf IV und V sowie Opel Astra. Mit MTS-System, d. h. zweifarbig-e Einlage in blau / schwarz ("sehen, was fehlt"), Einlage herausnehmbar, passt in alle gängigen Werkstattwagen, im stabilen Kunststoffkoffer

Universal 18-piece brake caliper rewind tool kit with right and left-hand drive; allows rewinding of the piston back into the bore on most disc brake calipers, allows servicing and replacement of worn pads on both wind back and push back type brakes; working pressure: 75-120 psi; fits most vehicles; with 3/8" ratchet adapter. Also suitable for VW Golf IV and V and Opel Astra. With MTS-System (two coloured hard foam module "see what is missing"), module removeable, fits into most common trolleys, in high quality plastic case

3/8"-Bremskolbenrückstellsatz

3/8"-Brake Caliper Rewind Tool Kit

3/8"



Art.-Nr. / No.	mm	"	g	VE	EUR	
0570 00 01	215	8.1/2	240	5	18,20	570/1
0570 00 02	350	14	400	5	30,50	

Zum Ein- und Aushängen der Bremsbacken-Rückholfelder bei aufgenieteten Bremsbelägen, für Trommelbremsen, mit Spezialeinfassung und Stützkrone, geeignet für genietete und geklebte Bremsbeläge, Oberfläche verchromt

For installing and removing the brake shoe recuperating spring on riveted brake linings, chrome plated

Bremsfedernzange

Brake Spring Pliers



Bremsen / Brakes

Bremsfedernzange Brake Spring Pliers



570/3

Für aufgenietete und aufgeklebte Bremsbeläge von Trommelbremsen, mit beweglicher Krallen, mit Spezial-einfassung und Stützkronen, verchromt

For riveted and glued brake linings on drum brake, with movable claw, easily removes and installs shoe return springs on most drum brakes, chrome plated

Art.-Nr. / No.	mm	"	g	VE	EUR
0570 00 03	330	13	470	1	44,50

Bremsseilfedernzange Brake Cable Spring Pliers



570/4

Zum Ein- und Aushängen von Handbremsseilen der Trommelbremsen, Spezialstahl, Gewerbe und Backen gehärtet, brüniert; Griffe vernickelt

For mounting and dismounting of the hand brake cable of drum brakes; compresses and removes spring on parking brake cable to help replace brake shoe arm; fits vehicles using cable / spring parking brake, assembly with rear drum brakes; features thin, head-treated jaws to fit into springs

Für / For:
VW / AUDI / SEAT, BMW, CITROEN, NISSAN, PEUGEOT, RENAULT, ROVER etc.

Art.-Nr. / No.	mm	g	VE	EUR
0570 00 04	215	175	5	31,00

Bremsfedernzange Brake Spring Pliers



570/5

Bremsfedernzange, zur Montage und Demontage der Blattfedern an den Belägen der Trommelbremsen, mit Montageanschlag, vernickelt / brüniert

Brake Spring Pliers, for mounting and removing of plate springs in drum brakes, nickel plated / black

Für / For:
MERCEDES BENZ (A), RENAULT (Clio, Twingo) etc.

Art.-Nr. / No.	mm	g	VE	EUR
0570 00 05	230	220	1	43,90

Splinttreiber Parallel-Pin Punches



718

Für Sicherungsstifte der Scheibenbremsen und Bremsbeläge in der Schwimm-Sattelbremse, geschliffene Triebspitze, DIN 6450 C, mit 8-kant-Schaft, lackiert

For the safety bolts of brake linings on floating caliper breaks, DIN 6450 C, taper section ground, with octagonal shape, lacquered

Ø3mm: Scheibenbremsen hinten / Rear disk brakes, MERCEDES-BENZ
Ø4mm: Scheibenbremsen / Disk brakes
Ø3 / 5,8mm: mit Führungszapfen / with guide pin OPEL

Art.-Nr. / No.	Ø mm	mm	g	VE	EUR
0718 00 20	3	175	65	10	6,95
0718 00 21	4	175	65	10	6,95
0718 00 22	3 / 5,8	175	60	10	6,95

Art.-Nr. / No.	↔ mm	⚖ g	📦 VE	EUR	852
0852 00 01	225	100	10	7,50	<p>Zum Entfernen von Bremsstaub und Schmutz im Bremssattel, für Scheibenbremssättel, schmale Ausführung, mit Kunststoffgriff und Aufhängebohrung</p> <p>For removal of brake dust and dirt from the caliper shaft, for disk brakes, slim design, with plastic handle and suspension hole</p>

Bremssattelbürste Brake Caliper Brush



Art.-Nr. / No.	↔ mm	⚖ g	📦 VE	EUR	854
0854 00 01	240	65	10	22,00	<p>Zum Entfernen von Bremsstaub, Schmutz und Rost im Bremssattel, für Scheibenbremssättel, Hieb: grob, einseitig (zum Schutz der Staubmanschette am Bremskolben), schräg verzahnt, 12mm breit, Spezialstahl, mit Kunststoffgriff und Aufhängebohrung</p> <p>For removal of brake dust, dirt and rust from the caliper shaft, for disk brakes, coarse level cut on one side (to prevent damage of dust boot), 12mm width, special steel, with plastic handle and suspension hole</p>

Bremssattelfeile Brake Caliper File



Art.-Nr. / No.	Dosen / tins	📦 ml	VE	EUR	8146/1
8146 00 01	1	500	1	2,50	<p>Der wirtschaftliche Problemlöser mit Wirkung:</p> <ul style="list-style-type: none"> - Löst Rost und festsitzende Verbindungen aller Art - Macht alles dauerhaft gleitfähig - Hocheffektiv gegen Quietschen und Knarren - Nachhaltiger Verschleißschutz - Schützt vor Korrosion - Abgefüllt in Deutschland <p>The cost-effective problem solver with effect:</p> <ul style="list-style-type: none"> - Removes rust and all other fixed compounds - Lubricates everything effectively - Highly effective against squeaking and creaking noises, effective wear and corrosion protection - Made in Germany
Karton / carton					
8146 00 21	10	500	1	24,00	
Palette / Pallett					
8146 00 31	680	500	1	1500,00	

Rostlöser Rust Remover



Art.-Nr. / No.	Dosen / tins	📦 ml	VE	EUR	8146/2
8146 00 02	1	500	1	2,95	<p>Statt mühseliger Arbeit - die starke Hilfe gegen verschmutzte Bauteile:</p> <ul style="list-style-type: none"> - Reinigt und entfettet Brems-, Kupplungs- und Getriebeteile, Anlasser, Vergaser etc. - Schnell abtrocknend - Mit speziellen Lösungsmitteln für hohe Wirksamkeit - Leichtentzündlich / abgefüllt in Deutschland <p>Instead of hard work: the auxiliary for dirty parts:</p> <ul style="list-style-type: none"> - Cleans and degreases brake, clutch and transmission parts, starter motors, carburetors etc. - Dries quickly - Even removes resinous deposits - Flammable / Made in Germany
Karton / carton					
8146 00 22	10	500	1	28,00	
Palette / Pallett					
8146 00 32	680	500	1	1800,00	

Bremsenreiniger Brake Cleaner / Anti-Rust Aerosol



Räder / Wheels

Bremsen-Servicesatz, 6-tlg. Set of Service Brake Tools, 6 pcs



8005

6-tlg. Satz mit den wichtigsten Werkzeugen für den Bremsenservice, inkl. GRATIS-Bremsenreiniger

6 pcs set with the most common tools for brake service, incl. free Brake Cleaner

Inhalt / contents:

- Bremsleitungsschlüssel / Flare Nut Wrench 10x11
- Bremssattelbürste / Brake Caliper Brush
- Bremssattel-Feile / Brake Caliper File 240mm
- Kunststoff-Abklemmzange / Line Clamp 0-60mm
- Metall-Abklemmvorrichtung / Hose Clamp Device
- GRATIS Bremsenreiniger / Free Brake Cleaner

Art.-Nr. / No.



g VE EUR

8005 00 05 6-tlg. / pcs. 800 1 41,95

Radmutternschlüssel für LKW Wheel Nut Wrenches for trucks



340/342

Für Nutzfahrzeuge, doppelseitig, 6-kant, Länge 400mm, für Drehstift-Durchmesser 18mm, Chrom-Vanadium-Stahl 31 CrV 3, matt verchromt

For trucks, double ended, 6 point, length 400mm, for tommy bar diameter 18mm, Chrome-Vanadium-Steel 31 CrV 3 (1.2208), matt chrome finish

Drehstifte, Chrom-Vanadium-Stahl 31 CrV 3, matt verchromt

Tommy Bars, Chrome-Vanadium-Steel 31 CrV 3 (1.2208), matt chrome finish

Art.-Nr. / No. mm " AF g VE EUR

Art.-Nr. / No.	mm	" AF	g	VE	EUR
0340 00 01	24x27	15/16x1.1/16	1150	1	29,90
0340 00 02	27x32	1.1/16x1.1/4	1150	1	35,00
0340 00 03	32x38	1.1/4x1.1/2	1150	1	39,00
0340 00 07	30x32		1150	1	35,80
0340 00 08	32x33		1150	1	37,10
0340 02 01	28x33	5/8x3/4	1600	1	36,90

Art.-Nr. / No.	Ømm	mm	g	VE	EUR
0342 00 02	18	500	1000	5	12,70
0342 00 07	18	600	1190	5	14,20

Kreuzschlüssel für PKW Four Way Rim Wrench for cars



350

Geschweißte Ausführung, für PKW, Transporter und Großraumlimousinen, mit SK-Profil (dadurch weit höhere Lebensdauer von Werkzeug und Radmutter - greift auch rundgedrehte Muttern), gehärtet, Spezialstahl, matt verchromt

Four Way Rim Wrench, for cars, with SK-Profil (thereby much longer service life of the wrench as well as the wheel nut), hardened, special steel, matt chrome plated

Art.-Nr. / No. mm mm g VE EUR

Art.-Nr. / No.	mm	mm	g	VE	EUR
0350 10 01	17x19x 21x1/2"	380	1300	5	12,50

Kreuzschlüssel für PKW Four Way Rim Wrenches for cars



352

Mit geschmiedetem Mittelstück, hoch belastbar, auf 500Nm geprüft (!), für PKW sowie leichte LKW und Landmaschinen, DIN 3119 / ISO 6788, Köpfe, Arme und Mittelstück gehärtet, Köpfe poliert, Spezialstahl, matt verchromt

With forged middle part, high capacity, tested up to 500Nm, for cars, light trucks and tractors; heads, DIN 3119 / ISO 6788, arms and middle part hardened, polished heads, special steel, matt chrome plated

Art.-Nr. / No. mm mm g VE EUR

Art.-Nr. / No.	mm	mm	g	VE	EUR
0352 00 01	17x19x 22x13/16"	400	1250	5	72,50
0352 00 02	17x19x 22x1/2"	400	1250	5	72,50



Art.-Nr. / No.	mm	kg	VE	EUR
0355 00 01	560	3	1	59,00
19 x 22 x 24 x 27mm = 3/4 x 7/8 x 15/16 x 1.1/16"				
0355 00 02	750	5	1	78,00
24 x 27 x 32 x 38mm + 13/16" = 15/16 x 1.1/16 x 1.1/4 x 1.1/2" + 13/16"				
0355 00 03	750	5	1	78,00
24 x 27 x 30 x 32mm + 13/16" = 15/16 x 1.1/16 x 1.3/16 x 1.1/4" + 13/16"				
0355 00 04	750	5	1	78,00
24 x 27 x 32mm x 3/4" + 13/16" = 15/16 x 1.1/16 x 1.1/4 x 3/4" + 13/16"				
0355 00 11	750	5	1	75,00
27 x 30 x 32 x 33mm = 1.1/16 x 1.3/16 x 1.1/4 x 1.5/16"				

355

Kreuzschlüssel für LKW
Four Way Rim Wrenches for trucks

Geschweißte Ausführung, für LKW, gehärtet, DIN 3119 / ISO 6788, Spezialstahl, lackiert

Four Way Rim Wrench, for trucks, fully hardened, special steel, varnished



Art.-Nr. / No.	mm	mm	kg	VE	EUR
0356 00 01	24x27x 30x32	750	5,6	1	135,00
0356 00 02	24x27x 32x 3/4"	750	5,6	1	135,00
0356 00 03	27x30x 32x33	750	5,6	1	135,00
0356 00 04	27x30x 32x3/4"	750	5,6	1	135,00

356

Kreuzschlüssel für LKW
Four Way Rim Wrenches for trucks

Mit geschmiedetem Mittelstück, hoch belastbar, auf 2000Nm geprüft (!), für LKW, DIN 3119 / ISO 6788, Köpfe, Arme und Mittelstück gehärtet, Köpfe poliert, Spezialstahl, matt verchromt

With forged middle part, high capacity, tested up to 2000Nm, for heavy trucks, DIN 3119 / ISO 6788, arms and middle part hardened, polished heads, special steel, matt chrome plated



Art.-Nr. / No.	mm	kg	VE	EUR
0357 00 01	24x27x 30x32	6	1	198,00
0357 00 02	24x27x 32x3/4"	5,9	1	203,00

357

Kreuzschlüssel für LKW
Four Way Rim Wrenches for trucks

Zerlegbarer Radmutterkreuzschlüssel für LKW, massives Mittelstück, mit Schraubsicherung, satzweise in robuster Segeltuchtasche, passt in jedes Fach

Divisible Four Way Rim Wrench for trucks, forged middle part, high capacity, set in strong canvas wallet, practical storage in busses and trucks



Art.-Nr. / No.	mm	kg	VE	EUR	
0358 00 01	24x27	15/16x1.1/16	3,9	1	58,00
0358 00 07	30x32		3,9	1	64,00
0358 00 08	32x33		3,9	1	65,00

358

Verlängerbarer Radmutter Schlüssel
Extendable Wheel Nut Wrench

4-tlg. Radmutter Schlüssel mit verlängerbarem Drehstift, für LKW, direkt entwickelt mit der Nutzfahrzeugindustrie, 400mm Radmutter Schlüssel für tiefliegende Schrauben, 2 Drehstifte und 1 Rohr als Mittelstück, in drei Stufen verlängerbar auf 1.200mm, Spezialstahl, auf 1.200Nm getestet, passt platzsparend in Staukasten

4 pcs set, wheel nut wrench with extendable tommy bar, for trucks, developed with leading OEM, 400mm wheel nut wrench reaches even deep screws, 2 tommy bars and 1 pipe as middle part, special steel, in 3 steps extendable up to 1,200mm, high capacity, tested up to 1,200Nm, fits in most storages

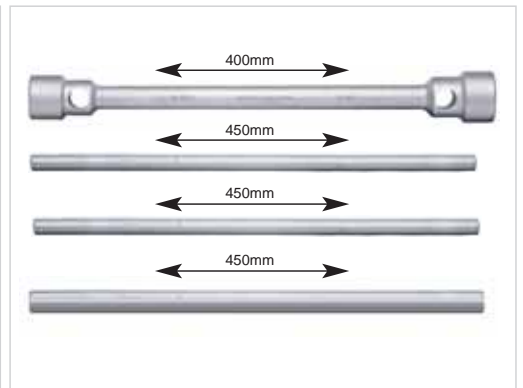

Auswuchtgewichtzange Balancing Weight Pliers



573

Zum Befestigen, Lösen, Verschieben und Abschneiden der Auswuchtgewichte an den Radfelgen, auch zum Aufweiten und Zusammendrücken der Haltefedern. Version mit Kunststoffschlagkopf insbesondere für Alu-Felgen und lackierte Gewichte. Chrom-Vanadium-Stahl 31 CrV 3, matt verchromt

For fixing, shifting, removing and cutting weights on wheel rims, also for expanding and compressing retaining springs. Type with plastic head esp. for alu rims and laquered weights. Chrome-Vanadium-Steel 31 CrV 3 (1.2208), matt chrome finish

Art.-Nr. / No.	mm	"	g	VE	EUR
0573 00 01	240	9.1/2	310	5	38,00
Mit Kunststoffschlagkopf / With plastic head					
0573 00 02	240	9.1/2	310	5	40,50
Ersatz-Schlagkopf / Spare plastic head					
0573 00 95			10	1	3,75

Reifenprofil-Tiefenmesser Brass Tyre Profile Depth Gauge



574

Blendfreie Ablesung, Messbereich 0-30mm, Ablesung in 0,1mm Schritten zur genauen Profiltiefen-Bestimmung, Anschlagfläche 23mm, leicht und sehr handlich, stabile Ausführung aus Messing, in Aufbewahrungstasche

Surfaces fine ground, glare-free reading, measuring depth 0-30mm, with dove-tail guiding, with verniere reading (graduation in 0.1mm steps), light weight, made of hard brass - very solid, in practical bag

Art.-Nr. / No.	mm	g	VE	EUR
0574 00 01	100	54	1	8,50

Spezial-Flachzange Special Flat Nose Pliers



585

Spezial-Flachzange mit Nute, z.B. für Radmutter-Schutzkappen an Alu-Felgen, verhindert Beschädigungen und Kratzer; auch für Ein- und Ausbau von Flachsicherungen geeignet; Backenlänge/-breite: 85/9mm, Spezialstahl, Kunststoffgriff

Enables the damage-free removal of wheel nut caps on aluminium rims; with groove, also suitable for flat protections etc., jaw length/width: 85/9mm, special steel, plastic handle

Für / For:
VW / AUDI, OPEL etc.

Art.-Nr. / No.	mm	"	g	VE	EUR
0585 00 14	160	8	200	1	9,95



Reifenmontierhebel Tyre Levers



752

Zum Auf- und Abziehen der Reifen, an Stahl- und insbesondere Alu-Felgen, Spitzen gehärtet, Chrom-Vanadium-Stahl 31 CrV 3, matt verchromt

For tire installation and removing, for steel and aluminium rims, tips hardened, Chrome-Vanadium-Steel 31 CrV 3 (1.2208), matt chrome finish

Anmerkung: Nicht als Hebeleisen geeignet - siehe hierzu MATADOR 754 - 759
Note: Not suitable as pry bar - pls. refer to MATADOR No. 754 - 759

Art.-Nr. / No.	mm	"	g	VE	EUR
0752 00 02	300	12	430	5	9,70
0752 00 03	400	16	650	5	11,80
0752 00 04	500	20	1000	5	14,20
0752 00 05	600	24	1200	5	17,70

Art.-Nr. / No.	↔		⚖	📦	g VE	EUR	753
	mm	"					
0753 00 02	400	16	620	5	13,60		
0753 00 03	500	20	790	5	16,50		
0753 00 04	600	24	970	5	18,80		

Schwere Ausführung, besonders für LKW, zum Auf- und Abziehen der Reifen, an Stahl- und insbesondere Alu-Felgen, Spitzen gehärtet, Chrom-Vanadium-Stahl 31 CrV 3, matt verchromt

Heavy pattern, especially for trucks, for tire installation and removing, for steel and aluminium rims, tips hardened, Chrome-Vanadium-Steel 31 CrV 3 (1.2208), matt chrome finish

Anmerkung: Nicht als Hebeleisen geeignet - siehe hierzu MATADOR 754 - 759
Note: Not suitable as pry bar - pls. refer to MATADOR No. 754 - 759



Reifenmontierhebel Tyre Levers



Art.-Nr. / No.	↔		⚖	📦	g VE	EUR	754
	mm	"					
0754 00 02	400	16	425	5	15,20		
0754 00 03	500	20	550	5	20,60		
0754 00 04	600	24	750	5	25,60		

Profilierte Ausführung mit T-Profil, besonders stabil, im Gesenk geschmiedet, zum Auf- und Abziehen der Reifen, an Stahl- und insbesondere Alu-Felgen, auch als Hebeleisen für vielfältige Einsatzbereiche verwendbar; Chrom-Vanadium-Stahl 31 CrV 3, matt verchromt

Double T-profile for high stability, heavy pattern, especially for trucks, for tire installation and removing, for steel and aluminium rims, also suitable for general purposes, Chrome-Vanadium-Steel 31 CrV 3 (1.2208), matt chrome finish

Reifenmontierhebel Tyre Levers



Art.-Nr. / No.	↔		⚖	📦	g VE	EUR	757-759
	mm	"					
0758 00 01	400	16	550	5	39,10		
0757 00 01	500	20	1050	5	29,80		
0759 00 01	400	16	510	5	26,20		

Rundkopf-Hebeleisen, für vielfältige Einsatzbereiche verwendbar; Chrom-Vanadium-Stahl 31 CrV 3
Pry Bar Round Head, Chrome-Vanadium-Steel 31 CrV 3 (1.2208), matt chrome finish

Mit 8-kant Schaft, Chrom-Vanadium-Stahl 31 CrV 3, matt verchromt
With octagonal shank, Chrome-Vanadium-Steel 31 CrV 3 (1.2208), matt chrome finish

Mit 4-kant Schaft, Chrom-Vanadium-Stahl 31 CrV 3, matt verchromt
With 4-pt. shank, Chrome-Vanadium-Steel 31 CrV 3, matt chrome finish

Hebeleisen Pry Bars



Art.-Nr. / No.	↔		⚖	📦	g VE	EUR	759/10
	mm						
0759 00 10	4-tlg. / pcs.		1800	1	49,50		
	200, 300, 450, 600mm						

Vielfältig einsetzbar, für Trenn- und Stemmarbeiten, z. B. im Instandsetzungsbereich von Lkw (z. B. für Spurstangen, Silentlager, Kugelenke, Fahrerhaus-Lager); durchgehende 4-kt.-Klinge für besonders hohe Belastung, Kunststoffgriff; Chrom-Vanadium-Stahl 31 CrV 3, matt verchromt

For heavy use, e.g. during repair work on trucks (for bearing bushings, cab bearings, cardan shaft slackness etc.); 4-pt. blade, with plastic handle, Chrome-Vanadium-Steel 31 CrV 3 (1.2208), matt chrome finish

Hebeleisen-Satz, 4-tlg. Set of Pry Bars, 4 pcs



Federspanner-Satz Coil Spring Compressor Set



563

3-tlg., zur Montage und Demontage aller gebräuchlichen Schraubfedern von Fahrzeugen bis max. 1500 kg Eigengewicht

3 pieces, for assembling and disassembling all usual coil springs for cars up to 1500 kg max. weight

Art.-Nr. / No.	mm	"	g	VE	EUR
----------------	----	---	---	----	-----

0563 00 30	300	12	4350	1	98,00
------------	-----	----	------	---	-------

Universal-Federspanner Universal Spring Compressor



563

Für MacPherson-Federbein- und Querlenkerachsen mit einem Feder-Ø von 110-180mm; Fahrzeuge bis max. 2000kg Eigengewicht; max. Belastung 3,5t; Antrieb SW 19; Stoßdämpfer-Wechsel ohne Ausbau des Federbeines; Sicherheitsbügel zum Schutz vor Verrutschen; Schlagschrauber-Bedienung erlaubt

For MacPherson suspension units; range of uses: MacPherson suspensions with spring-Ø from 110-180mm; for changing shock absorbers without removing the suspension strut; with safety guard; use of impact driver permitted

Art.-Nr. / No.	mm	mm	kg	VE	EUR
----------------	----	----	----	----	-----

0563 00 10	240	110-180	3,5	1	198,00
------------	-----	---------	-----	---	--------

Universal-Federspanner Universal Spring Compressor



563

Universal-Federspanner mit Sicherheitsbügel; für Fahrzeuge mit einem Eigengewicht bis max. 2.000 kg geeignet; entspricht den Forderungen der "Sicherheitsregeln für die Fahrzeuginstandhaltungen" (ZH1/454) der Berufsgenossenschaft; sicheres Greifen durch breite Auflagefläche und Prismenform der Dreipunktauflage; max. Belastung: 1,8t; Antrieb: SW 19

Universal spring compressor with safety guard; for vehicles with an unladen weight of 2 tons; max. capacity of 1,8 tons; drive 19mm; safe grip

Art.-Nr. / No.	mm	mm	kg	VE	EUR
----------------	----	----	----	----	-----

0563 00 40	200	110-180	2,8	1	168,00
0563 00 50	300	110-180	3,1	1	178,00
0563 00 60	400	110-180	3,4	1	188,00

Universal-Sturz-Einstellwerkzeug Universal Lintel Adjusting Tool



731

Besonders stabile Ausführung: Spindel mit Rechts- und Linksgewinde M 14, kein Verbiegen. Sturz-Einstellarbeiten am Fahrzeug können alleine durchgeführt werden - hohe Zeitersparnis - Werkzeug einfach zwischen Karosserie und Radfelge setzen; Köpfe / Enden PVC-beschichtet zum Felgenschutz

Very solid type, for adjusting and setting camber angles, spindle with left/right thread M 14; work can be done only by one person, just place the tool between the strut / body and the wheel rim. PVC-covered single heads / ends are - no damaging of the rims

Art.-Nr. / No.	mm	g	VE	EUR
----------------	----	---	----	-----

0731 00 03	60-210	980	1	69,00
------------	--------	-----	---	-------

Inhalt / contents:
 1x Sturzeinstellwerkzeug / Spindel
 1x Sechskantmutter / Bolt 60mm
 1x Sechskantmutter / Bolt 75mm
 1x Sechskantmutter / Bolt 85mm

Art.-Nr. / No.	kg	VE	EUR	ModuFlex L 880	
0880 30 01 25-tlg. / pcs.	18	1	298,00		

Universell anwendbarer Radlagersatz zur Demontage und Montage von Radlagern, Buchsen, Gummilagern, Schwingungsdämpfern, Federtellern, Kopflager, Kugellagern, Walzenlagern, Stift- und Bolzenlagern etc. ohne Ausbau der Federbeine, Sturzeinstellung entfällt; Anwendung direkt am Fahrzeug; mit extrem stark ausgelegter Gewindespindel mit Feingewinde für hohe Kraftwirkung, komplett mit den wichtigsten Adaptern; Druckhülsen, Abdrückbolzen für Radnaben etc.; mit Montageanleitung. Mit MTS-System, d. h. zweifarbige Einlage in blau / schwarz ("sehen, was fehlt"), Einlage herausnehmbar, passt in alle gängigen Werkstattwagen, im stabilen Kunststoffkoffer

For the change of built-in wheel bearings, removing of strut unit as well as adjustment of king pin inclination not necessary. You can take off the hub, remove the old bearing, install the new one, and reinstall the hub, all while the knuckle assembly remains on the car. Cuts 50% off service time when replacing wheel bearings. With MTS-System (two coloured hard foam module "see what is missing"), module removeable, fits into most common trolleys, in high quality plastic case

Inhalt / contents:
 9x Adapter / adapters (55,5 - 59 - 62 - 65 - 66 - 71,5 - 73 - 78 - 84mm)
 1x Drückhülse / housing 76mm
 2x Druckgehäuse / housing 86 - 91mm
 1 x Gewindespindel / threaded spindle 295mm
 Diverse Abdrückbolzen und Kleinteile / several parts

Universal-Radlagerwerkzeug-Satz

Universal Wheel Bearing Extractor Set

Art.-Nr. / No.	mm	g	VE	EUR	4078	
4078 00 31	48	66	10	11,80		

Für das beschädigungsfreie Aufweiten von Federbein- und Traggelenkaufnahmen (z.B. Trennen des Federbeins vom Radlagergehäuse); Klinge schwarz, Chrom-Vanadium-Stahl 31 CrV 3, matt verchromt

For spreading of the front shock absorber tube from the wheel bearing housing, blade black, Chrome-Vanadium-Steel 31 CrV 3 (1.2208), matt chrome finish

Für / For:
 VW / AUDI, FORD, PEUGEOT etc.

Aufspreizer für Federbeine

Spreader for shock absorbers

1/2"

Art.-Nr. / No.	mm	g	VE	EUR	5079	
5079 09 01	M 18 80	95	1	24,80		

Spezialeinsatz zur De- und Montage der Radnaben / Radlagereinheiten (Halteschraube an der Hinterachse); wird am Achszapfen angesetzt und mit der Montageschraube am Achszapfen montiert; für B&S-XZN - Schrauben, für Handbetätigung, Chrom-Vanadium-Stahl 31 CrV 3, matt verchromt

Special Socket for pulling the wheel hubs / wheel bearing units off stub axle; for B&S-XZN screws, for manual drive, Chrome-Vanadium-Steel 31 CrV 3 (1.2208), matt chrome finish

Für / For:
 VW / AUDI (Touran, A3) etc.

Spezialeinsatz XZN für Federbeine

Special Socket XZN for wheel hubs

3/4"

Auspuff / Lambdasonden / Schlauchklemmen

Exhaust System / Lambda Probes / Hose Clamps



Auspuff-Klemmfedernspanner Spring Spanner for exhaust systems

564/1

Art.-Nr. / No. \longleftrightarrow mm $\left[\begin{array}{c} \text{g} \\ \text{VE} \end{array} \right]$ EUR

3/8"



Für die Montage und Demontage der Klemmfedern am Kugelflansch, z. B. VW-Auspuffanlagen, bei denen der Auspuff nicht verschraubt ist, sondern mit Federn an den Abgaskrümmern geklemmt wird; die Spannkraft der Klemmfedern ist sehr hoch und nur mit diesem Spezialwerkzeug sicher zu lösen; mit 3/8"-Antrieb / SW 17 beidseitig, Spezialstahl, verzinkt

For mounting and dismounting of the steel clamps on the exhaust systems, e.g. VW; 3/8" drive / 17mm spanner to be used on both sides; special steel, zinc plated

0564 00 01 140-330 750 1 52,00

Auspuff-Ziehhaken, universal Universal Mounting Hook

564/2

Art.-Nr. / No. \longleftrightarrow mm $\left[\begin{array}{c} \text{g} \\ \text{VE} \end{array} \right]$ EUR



Zur Montage und Demontage von Haltegummis an Abgasanlagen; anwendbar bei den meisten Fahrzeugtypen; mit tauchisoliertem Griff, Spezialstahl

For mounting and dismounting of the rubber retainers of exhaust pipes and equipment; universal hook - suitable for most car types; handle isolated, special steel

0564 00 02 300 200 1 11,50

Spannkeile-Satz, 3-tlg. Wedge Set, 3 pcs

564/3

Art.-Nr. / No. $\left[\begin{array}{c} \text{g} \\ \text{VE} \end{array} \right]$ EUR



Zur Montage und Demontage der Auspuff-Federklammern am Kugelflansch von VW-Abgasanlagen

For mounting and dismounting of the steel clamps with and without location hole on the flange on VW-AUDI exhaust manifolds

Für / For:
VW / AUDI

0564 00 03 3-tlg. / pcs. 650 1 19,50

Art.-Nr. / No.	mm	g	VE	EUR	808/10
0808 00 10	255	800	1	55,00	<p>Zum Trennen insbesondere von Auspuffrohren bis 80mm Ø und bis 2,5mm Wandstärke, auch für Rohre aus VA-Stahl, Kupfer und PVC; besonders geeignet für die Demontage von alten Auspuffanlagen; aus vergüteten Stahl; durch Grip-Zange geringer Kraftaufwand - die Flügelschraube ermöglicht das leichte Nachstellen; Schneidradchen aus hochfesten Spezialstahl; vernickelt</p> <p>For cutting exhaust pipes up to 80mm Ø and 2,5mm thickness; for V2A-steel, copper and PVC, especially for dismantling old exhaust systems; T-screw and grip plier technique enable easy adjustment during cutting process; high grade tool steel, nickel plated</p>
Ersatzkette / Spare chain 0808 00 11		190	1	49,00	

Ketten-Rohrabschneider Chain Pipe Cutter



Art.-Nr. / No.	mm	mm	g	VE	EUR	3081/4081
3/8": 3081 00 60 Schlitz/ Groove:	22	80	225	1	19,00	<p>Für Arbeiten an Lambda-Sonden, Diesel-Einspritzdüsen und Thermo-Schaltern; auch an schwer zugänglichen Stellen, Einsätze extra tief, geschlitzt für Kabeldurchführung, mit flacher Nut und ohne Fase - ermöglicht sicheren Halt des Werkzeugs; 6-kant, Chrom-Molybdän-Stahl 42 CrMo 4; brüniert</p> <p>For working on catalytic converters, Lambda probes, fuel injector nozzles and thermostat switches on electric cooler fans, especially for probes with non-detachable cable, perfect connection with the hexagone profile of the Lambda probe due to cut step and chamfer-free profile; 6-pt., special steel, black phosphated</p> <p>z.B. / e.g.</p> <ul style="list-style-type: none"> - für den Ein- und Ausbau von Lambda-Sonden / for the installation and removal of lambda probes: 3081 00 60 - 22mm 3081 00 61 - 22mm 3081 00 62 - 22mm mit Winkel / angular short 4081 00 69 - 22mm mit Winkel / angular long 3081 00 63 - 27mm - zur Montage von Diesel-Einspritzdüsen ohne Beschädigung der Kraftstoff-Rücklaufrohrchen / for installing Diesel-fuel injector nozzles: 4081 00 60 - 27mm - für Thermo-Schalter / For installation and removal of the thermostat switch (Opel Corsa B, Astra F+G, Vectra A+B): 4081 00 70 - 29mm
3081 00 61 Schlitz/ Groove:	22	90	225	1	19,00	
3081 00 62 Höhe/ Height:	22	80	225	1	19,00	
3081 00 63	27	74	225	1	22,00	
1/2": 4081 00 69 Höhe/ Height:	22	58	225	1	21,00	
4081 00 60 Schlitz/ Groove:	27	90	225	1	22,00	
4081 00 70 Schlitz/ Groove:	29	90	225	1	25,00	
MTS-Satz komplett / Full set in MTS module 4081 00 95 7-tlg. / pcs.			1500	1	98,50	

Lambdasonden-Einsätze Oxygen / Lambda Sockets

3081 00 60	<input type="checkbox"/>	3/8"	
3081 00 61	<input type="checkbox"/>		
3081 00 62	<input type="checkbox"/>		
3081 00 63	<input type="checkbox"/>		
4081 00 69	<input type="checkbox"/>	1/2"	
4081 00 60	<input type="checkbox"/>		
4081 00 70	<input type="checkbox"/>		



Schlauchklemmen / Hose Clamps

Schlauchklemmenzange Hose Clamp Pliers



548/1

Für einfache Schlauchschellen und insbesondere für Federbandschellen an Kühlmittelschläuchen, mit drehbaren Haltebolzen, Spannungsbereich 6-12mm, Chrom-Vanadium-Stahl 31 CrV 3, vernickelt

For universal clamps and especially for spring band hose clamps, with moveable jaws, Chrome-Vanadium-Steel 31 CrV 3 (1.2208), nickle plated

Für / For:
VW / AUDI, OPEL

Art.-Nr. / No.	mm	g	VE	EUR
0548 00 01	200	180	5	32,60

Schlauchklemmenzange CLIC-R Hose Clamp Pliers CLIC-R



548/11

Geschmiedete Ausführung, zum Schließen und Öffnen von wiederverwendbaren CLIC-Schlauchschellen; insbesondere bei Kraftstoffleitungen; mit integrierter Öffnungsfeder; kompakte Bauweise - auch auf engstem Raum einsetzbar; mit Kunststoffgriffhüllen, Spannungsbereich 5-30mm; Spezialstahl, verchromt

Drop forged, for multi-use CLIC hose clips, esp. on fuel lines, with integrated opening spring; compact construction, also in narrow spaces; with plastic coated handles; Ø 5-30mm; special steel, chrome finish

Für / For:
VW / AUDI, MERCEDES BENZ, OPEL etc.

Art.-Nr. / No.	mm	g	VE	EUR
0548 00 11	175	205	5	38,90

Schlauchklemmenzange Oetiker Hose Clamp Pliers Oetiker



548/2

Für wiederverwendbare Schellen (z. B. Oetiker-Serie), sicheres Öffnen und Schließen von stufenlosen Spannschellen ohne Ohr - z. B. für Achsmanchetten, Spezialstahl, vernickelt

For multi-use clamps (e.g. Oetiker series) without ear; safe opening and closing; e.g. for axle gaskets; special steel, nickle plated

Für / For:
VW / AUDI, MERCEDES BENZ, TOYOTA etc.

Art.-Nr. / No.	mm	g	VE	EUR
0548 00 02	180	172	1	41,70



Schlauchklemmenzange Hose Clamp Pliers



548/3

Für selbstspannende Schlauchschellen mit flachen 3 Klemm-Enden (Typ W) - liegen direkt auf dem Schlauch; Zange mit Prismen-Aufnahme, insbesondere für Kraftstoffleitungen, Kühl- und Waschwasserschläuchen; Spannungsbereich 8-18mm; Spezialstahl, vernickelt

For tips contacting directly the tube (Type W), with prism seat for spring band clamps, esp. for fuel lines etc., special steel, nickle plated

Für / For:
VW / AUDI, MERCEDES BENZ, TOYOTA etc.

Art.-Nr. / No.	mm	g	VE	EUR
0548 00 03	195	165	1	31,90



Art.-Nr. / No.	mm	g	VE	EUR	
0548 00 04	210	560	1	38,90	<p>548/4 Schlauchklemmzange Hose Clamp Pliers</p> <p>Mit drehbaren Aufnahmen, für selbstspannende Schlauchschellen mit flachen 3 Klemm-Enden (Typ W) - liegen direkt auf dem Schlauch; insbesondere für Tankbelüftungsschläuche, Kraftstoffleitungen, Kühl- und Waschwasserschläuchen; Spannungsbereich 8-18mm; Spezialstahl, vernickelt</p> <p>With moveable jaws, for tips contacting directly the tube (Type W), with prism seat for spring band clamps, esp. for fuel lines etc., capacity 8-18mm; special steel, nickle plated</p> <p>Für / For: VW / AUDI, MERCEDES BENZ, TOYOTA etc.</p>



Art.-Nr. / No.	mm	g	VE	EUR	
0548 00 20	255	560	1	83,00	<p>548/20 Schlauchklemmzange Hose Clamp Pliers</p> <p>Für schwer zugängliche, selbstspannende Schlauchschellen im Motorraum, Einhandbedienung; insbesondere im Bereich von Kühl- und Heizungssystemen, Spannweite 18-52mm, selbstverstellbares Gewerbe, mit Bowdenzug (610mm) und Arretierung, Spezialstahl, vernickelt</p> <p>For self-gripping spring band hose clamps; one-hand operation; esp. for areas with restricted access; e.g. on cooling and heating circuits, with self adjusting joint and bowden cable wire control, nickle plated</p> <p>Für / For: VW / AUDI, MERCEDES BENZ, TOYOTA etc.</p>
Ersatzbowdenzug / Spare bowden puller 0548 00 21		45	1	10,50	
Ersatz-Klammer / Spare clamp 0548 00 22		10	1	7,50	



Art.-Nr. / No.	mm	mm	g	VE	EUR	
0587 00 10	0-15	150	50	5	12,10	<p>587 Schlauchklemmzange Hose Clamp Pliers</p> <p>Zum Abklemmen von flexiblen Leitungen wie z.B. Heizungs- und Benzinschläuche, gelbe Signalfarbe, aus Kunststoff</p> <p>For clamping flexible lines e.g. heater and fuel injection, yellow signal colour, plastic</p>
0587 00 20	0-30	180	85	5	16,40	
0587 00 30	0-60	255	130	5	19,90	
3-tlg. Satz / Set 3-pcs. 0587 01 00			300	1	45,80	



Art.-Nr. / No.	mm	g	VE	EUR	
0849 00 02	bis ca. 25	40	1	6,00	<p>849 Schlauchklemmen-Vorrichtungen Hose Clamp Devices</p> <p>Abklemm-Vorrichtung für Schläuche bzw. Benzinleitungen; besonders stabile Ausführung mit Gewindebügel aus stabilem Rundstahl; Andrückplatte aus Blech, dadurch erhöhter Anpressdruck; griffige Anschraub-Muttern aus Kunststoff mit innenliegender Stahl-Gewindebüchse</p> <p>Hose Clamp Device, for gasoline lines, very solid pattern with threading bow (solid round steel), raised contact pressure due to sheet metal plate, well gripping plastic nuts and inside steel threaded sleeve</p> <p>Für / For: VW / AUDI, MERCEDES BENZ, TOYOTA etc.</p>
0849 00 03	bis ca. 40	90	1	6,50	



Batterie / Kühlsystem / Battery / Cooling System



Autolichtprüfer Car Light Tester

632

Art.-Nr. / No.	mm	mm	mm	g	VE	EUR
----------------	----	----	----	---	----	-----

0632 00 01	3	50	115	20	10	2,40
------------	---	----	-----	----	----	------



Autolichtprüfer, mit Kabel, 6-24 Volt, zur Kontrolle von Licht- und Zündanlagen, z.B. zum Prüfen von Zündkerzen auf Funktion und Verschmutzung für Standard-Zündkerzen mit einer Elektrode, Linse und Metallclip, vernickelt

Car Light Tester, with cable, 6-24 V, for checking lighting and ignition systems, with metal clip, nickel plated



Spannungsprüfer Voltage Tester

633

Art.-Nr. / No.	mm	g	VE	EUR
----------------	----	---	----	-----

0633 00 01	120	75	10	6,05
------------	-----	----	----	------



Zum Prüfen der Spannung, 6 bis 24V-Ausführung mit Spitze, geschraubter Schutzkappe, festem Kabel und Klemme, Klinge aus Chrom-Vanadium 31 CrV 3, W.-Nr. 1.2208

Voltage tester, testing range 6 to 24V, with tip, protective cap, fixed cable and clip, blade Chrome-Vanadium steel 1.2208

Batterietester Battery Cell Tester

633/10

Art.-Nr. / No.	g	VE	EUR
----------------	---	----	-----



0633 00 10	1220	1	185,00
------------	------	---	--------



Zur Diagnose des Ladesystems und des Spannungszustandes der Batterie; Messbereich 6 und 12 Volt bis 1.000 CCA; mit deutlicher Skala; 100 Ampere; für Motorräder und Pkw

Fast diagnosis of the charging system and state of the battery; measuring range 6 and 12 Volt up to 1000 CCA; with easy to read display, for up to 100 Ampere; for passenger cars and motorcycles

Art.-Nr. / No.	↔ mm	⚖️ g	📦 VE	EUR	783
0783 00 01	120	20	10	12,50	

Zum Reinigen von Batteriepolklemmen, im Kunststoffbehälter

For cleaning battery terminals, in plastic box

Batterie-Polklemmenbürste Battery Terminal Brush



Art.-Nr. / No.	↔ mm	⚖️ g	📦 VE	EUR	805
0805 00 01	290	60	1	16,50	
0805 00 02	150	40	1	6,50	

Zum Prüfen der Säuredichte, für konventionelle Batterien mit Schraubdeckeln, mit Aräometer

For controlling the acid content of the battery fluid, for conventional batteries with screw caps, with aerometer

Batteriesäure-Prüfer / -Füller Battery Acid Tester / - Filler



Batterie-Füller, zum Füllen herkömmlicher Batterien mit Schraubdeckeln, säurebeständig, mit Gummiball und PVC-Rohr

For filling conventional batteries with screw caps, acid-resistant, with rubber ball and PVC tube



Art.-Nr. / No.	↔ mm	⚖️ g	📦 VE	EUR	806
0806 00 02	130	170	1	33,00	

Zum Messen von Kühlerfrostschutz und Scheibenwischwasser, für alle Ethylenglykol-Frostschutzmittel; hohe Messgenauigkeit bei jeder Kühlwassertemperatur; Ansaugball aus Elastomer- bleibt bei allen Temperaturen elastisch und voll funktionsfähig; hydrastische Sperre verhindert automatisch jedes Ausfließen und das Nachziehen von Luft; 360° drehbar; patentiertes Ansaugsystem; aus schlagfestem Kunststoff, absolut korrosionsbeständig

For testing antifreeze / windshield washer fluids, for all Ethylenglykol-liquids,

Frostschutzprüfer Antifreeze Tester



Art.-Nr. / No.	⚖️ g	📦 VE	EUR	806/10
0806 00 10	300	1	95,00	

Zum Messen von Kühlerfrostschutz (0 bis -50°C), Scheibenwischwasser (0 bis -40°C) und Batteriesäuredichte (1,1 bis 1,4 Kg/L.), 3 Funktionen in einem Gerät; für Autobatterien und Frostschutzmittel auf Propylen- und Ethylenbasis, auch für VW G11 / 12; bewährtes Werkstattprüfgerät; mit justierbarem Okular zur Einstellung der Sehstärke des Anwenders; stabiles Metallgehäuse, mit Entnahmepipette

Designed to test coolant (from 0 to -50°C); windshield washer fluids (from 0 to -40°C) and battery acid (from 1.1 to 1.4 Kg/L.). Approved by vehicle manufacturers; easy reading of results; adjustable diopter for optimal viewing, with PVC tube, metal tube

Refraktometer "3 in 1" Refractometer "3 in 1"





MATADOR Kabelentriegeler bieten Ihnen entscheidende Vorteile:

- hohe Belastbarkeit
- absolute Maßgenauigkeit
- geringe Rautiefe

MATADOR Release Tools offer you special advantages as:

- high durability
- dimensional accuracy
- less peak-to-valley height



Alle Entriegelungswerkzeuge werden nach Beendigung des Fertigungsprozesses im Gleitschleifverfahren behandelt, um Beschädigungen an Kontakten und Gehäusen auszuschließen. Fragen Sie uns, wenn Sie zusätzliche Informationen benötigen.

After the main manufacturing process all our tools are treated in a special way of polishing to avoid any damage on connectors and contacts.

Ask us and we will try to solve your problems.

Universal-Entriegelungssatz PKW Universal Set of Extraction Tools

800/1 ModuFlex L

Art.-Nr. / No.  g  VE EUR



Universal-Satz, die gängigsten Kabelentriegler für PKW, für beschädigungsfreies Entriegeln von Steckkontakten, Störungen durch Fehlverbindungen können schnell und mühelos behoben werden, 10-tlg.

Set of main extraction tools for cars, for release of connectors without any damage, malfunctions due to defective connections can be repaired fast and easily, 10 pcs.



0800 00 01 10-tlg. / pcs. 600 1 **248,00**

Inhalt / Contents:

- 4x Flachsteckwerkzeug / Flat Terminal Extractors (0800 00 12 / 13 / 14 / 15)
- 3x Gabelwerkzeug / Fork Terminal Extractors (0800 00 20 / 25 / 29)
- 1x Hakenwerkzeug / Hook Remover (0800 00 35)
- 2x Rundsteckwerkzeug / Circular Terminal Extractors (0800 00 38 / 41)

Universal-Entriegelungssatz NFZ Set of Standard Extraction Tools

800/2 ModuFlex L

Art.-Nr. / No.  g  VE EUR



Universal-Satz, die gängigsten Kabelentriegler für Nfz, für beschädigungsfreies Entriegeln von Steckkontakten, Störungen durch Fehlverbindungen können schnell und mühelos behoben werden, 10-tlg.

Set of main extraction tools for commercial vehicles and trucks, for release of connectors without any damage, malfunctions due to defective connections can be repaired fast and easily, 10 pcs.



0800 00 02 10-tlg. / pcs. 600 1 **268,00**

Inhalt / Contents:

- 2x Flachsteckwerkzeug / Flat Terminal Extractors (0800 00 10 / 12)
- 3x Gabelwerkzeug / Fork Terminal Extractors (0800 00 17 / 19 / 24)
- 5x Rundsteckwerkzeug / Circular Terminal Extractors (0800 00 38 / 40 / 41 / 43 / 44)

Entriegelungssatz, VW Set of Extraction Tools, VW

800/3 ModuFlex L

Art.-Nr. / No.  g  VE EUR



Die gängigsten Kabelentriegler für VW, für beschädigungsfreies Entriegeln von Steckkontakten, Störungen durch Fehlverbindungen können schnell und mühelos behoben werden, 10-tlg.



Set of main extraction tools for Volkswagen cars, for release of connectors without any damage, malfunctions due to defective connections can be repaired fast and easily, 10 pcs.

0800 00 03 10-tlg. / pcs. 600 1 **268,00**

Inhalt / Contents:

- 3x Flachsteckwerkzeug / Flat Terminal Extractors (0800 00 11 / 12 / 15)
- 6x Gabelwerkzeug / Fork Terminal Extractors (0800 00 18 / 20 / 22 / 24 / 27 / 29)
- 1x Rundsteckwerkzeug / Circular Terminal Extractors (0800 00 38)



Für / For:
VW / AUDI / SEAT / SKODA

Art.-Nr. / No.	 g	 VE	EUR	ModuFlex L 800/4
0800 60 04 20-tlg. / pcs.	850	1	485,00	
<p>Die gängigsten Kabelentriegler für VW, für beschädigungsfreies Entriegeln von Steckkontakten, Störungen durch Fehlverbindungen können schnell und mühelos behoben werden, 20-tlg.</p> <p>Set of main extraction tools for Volkswagen cars, for release of connectors without any damage, malfunctions due to defective connections can be repaired fast and easily, 20 pcs.</p> <p>Für / For: VW (Golf 1-5, Jetta, Polo 3, Passat, Passat VR6, Lupo, Sharan, LT2, T3, T5, Corrado), AUDI (A3, A4, A6, 80, 200)</p>				
<p>Inhalt / Contents:</p> <p>4x Flachsteckwerkzeug / Flat Terminal Extractors (0800 00 11 / 12 / 13 / 15)</p> <p>12x Gabelwerkzeug / Fork Terminal Extractors (0800 00 18 / 20 / 22 / 23 / 24 / 25 / 26 / 27 / 28 / 29 / 30 / 33)</p> <p>4x Rundsteckwerkzeug / Circular Terminal Extractors (0800 00 36 / 37 / 38 / 42)</p>				

Entriegelungssatz, VW

Set of Extraction Tools, VW





Art.-Nr. / No.	 g	 VE	EUR	ModuFlex L 800/5
0800 60 05 10-tlg. / pcs.	600	1	278,00	
<p>Die gängigsten Kabelentriegler für Mercedes Benz, für beschädigungsfreies Entriegeln von Steckkontakten, Störungen durch Fehlverbindungen können schnell und mühelos behoben werden, 10-tlg.</p> <p>Set of main extraction tools for Mercedes Benz cars, for release of connectors without any damage, malfunctions due to defective connections can be repaired fast and easily, 10 pcs.</p> <p>Für / For: MERCEDES BENZ</p>				
<p>Inhalt / Contents:</p> <p>3x Flachsteckwerkzeug / Flat Terminal Extractors (0800 00 12 / 15 / 16)</p> <p>4x Gabelwerkzeug / Fork Terminal Extractors (0800 00 19 / 20 / 29 / 32)</p> <p>2x Rundsteckwerkzeug / Circular Terminal Extractors (0800 00 39 / 41)</p> <p>1x Spezialwerkzeug / Special Tools (0800 00 46)</p>				

Entriegelungssatz, Mercedes Benz

Set of Extraction Tools, Mercedes Benz



Art.-Nr. / No.	 g	 VE	EUR	ModuFlex L 800/6
0800 60 06 20-tlg. / pcs.	850	1	528,00	
<p>Die gängigsten Kabelentriegler für Mercedes Benz, für beschädigungsfreies Entriegeln von Steckkontakten, Störungen durch Fehlverbindungen können schnell und mühelos behoben werden, 20-tlg.</p> <p>Set of main extraction tools for Mercedes Benz cars, for release of connectors without any damage, malfunctions due to defective connections can be repaired fast and easily, 20 pcs.</p> <p>Für / For: MERCEDES BENZ</p>				
<p>Inhalt / Contents:</p> <p>5x Flachsteckwerkzeug / Flat Terminal Extractors (0800 00 11 / 12 / 13 / 15 / 16)</p> <p>8x Gabelwerkzeug / Fork Terminal Extractors (0800 00 19 / 20 / 21 / 25 / 29 / 31 / 32 / 34)</p> <p>1x Hakenwerkzeug / Hook Remover (0800 00 35)</p> <p>4x Rundsteckwerkzeug / Circular Terminal Extractors (0800 00 36 / 38 / 39 / 41)</p> <p>2x Spezialwerkzeug / Special Tools (0800 00 45 / 46)</p>				

Entriegelungssatz, Mercedes Benz

Set of Extraction Tools, Mercedes Benz



Flachsteckwerkzeuge / Flat Terminal Extractors

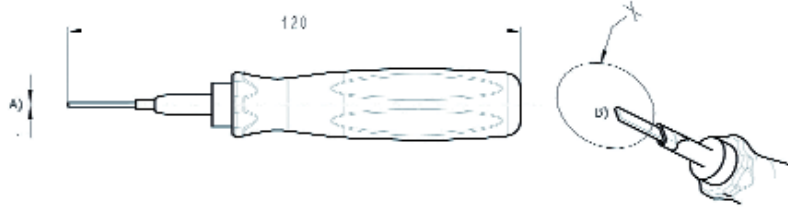

Flachsteckwerkzeuge dienen zur Entriegelung von Kontakten, die nur mit einer Rastzunge im Gehäuse verankert sind. Zum Beispiel zur Entriegelung von Fastin-Faston und Steckhülsen.

Flat terminal extraction tools are designed for the release of contacts that are fixed with one snap-in pin inside the connector. Contact samples are e.g. Quadlock, receptacles, Fastin-Faston, Metri-Pack, SIKO and many more.

A = Stärke / thickness
B = Stegbreiten / breadth of pins
Alle Maßangaben in mm / all measurements in mm

Flachsteckwerkzeuge Flat Terminal Extractors

800

Art.-Nr. / No. A B VE EUR

	Für / For: Audi, DaimlerChrysler, Ford, GM, Jaguar, MAN, Peugeot / Citroen, Rolls Royce, Toyota	0800 00 10	1,00	1,60	1	19,00
		Kontaktmaß / Contact Dimensions: 1,50; 2,80; 4,80mm				
	Für / For: Audi, BMW, DaimlerChrysler, Ford, GM, Jaguar, Rolls Royce, VW	0800 00 11	1,00	2,70	1	19,00
		Kontaktmaß / Contact Dimensions: 2,80; 4,80; 6,30mm				
	Für / For: Alfa Romeo, Audi, BMW, DaimlerChrysler, Ford, GM, Jaguar, Nissan, Porsche, Peugeot / Citroen, Rolls Royce, Toyota, VW	0800 00 12	1,00	3,00	1	19,00
		Kontaktmaß / Contact Dimensions: 1,50; 2,80; 4,80; 6,30; 9,50mm				
	Für / For: Audi, DaimlerChrysler, Ford, GM, Jaguar, Nissan, Peugeot / Citroen, Renault, Rolls Royce, smart, Toyota, Volvo, VW	0800 00 13	1,00	1,90	1	19,00
		Kontaktmaß / Contact Dimensions: 1,50; 2,80; 4,80; 6,30mm				
	Für / For: Audi, BMW, Ford, GM, Jaguar, Nissan, Renault, smart, Toyota, VW	0800 00 14	0,50	0,80	1	19,00
		Kontaktmaß / Contact Dimensions: 0,63; 1,00; 1,50mm				
	Für / For: Alfa Romeo, Audi, BMW, DaimlerChrysler, Ford, GM, Jaguar, Nissan, Porsche, Peugeot / Citroen, Rolls Royce, Toyota, VW	0800 00 15	1,00	1,00	1	19,00
		Kontaktmaß / Contact Dimensions: 0,63; 0,64; 1,00; 1,50; 1,70; 2,80mm				
	Für / For: BMW, Ford, GM, Peugeot / Citroen, Renault, Rolls Royce, Toyota, Volvo, VW	0800 00 16	0,70	1,30	1	19,00
		Kontaktmaß / Contact Dimensions: 0,63 x 0,63; 2,50mm				

Gabelsteckwerkzeuge / Fork Terminal Extractors

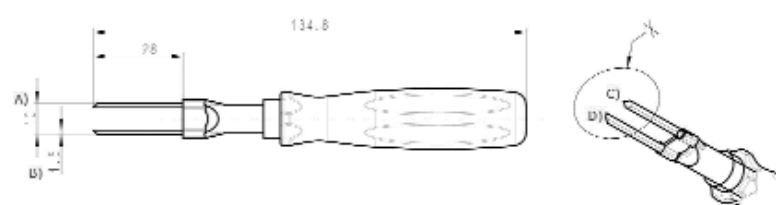

Gabelwerkzeuge wurden zur Entriegelung von Gehäuse und Kontaktsystemen, wie z.B. Junior-Power-Timer, DFK und Ducon entwickelt, die mit mindestens zwei Verrastungen im Gehäuse verankert sind.

Fork Terminal Extractors are designed for the re-oval of contacts which are fixed at least with two detents inside the connector, for example Junior-Power-Timer, DFK and Ducon.

A = Gabelbreite / breadth of forked blade
B = Stegbreiten / breadth of pins
C = Innenmaß / inside measurement
D = Stegtiefen / depth of pins
Alle Maßangaben in mm / all measurements in mm

Gabelsteckwerkzeuge Fork Terminal Extractors















800

Art.-Nr. / No. A B C D VE EUR

	Für / For: Alfa Romeo, Audi, BMW, DaimlerChrysler, Ford, GM, Porsche, smart, VW	0800 00 17	4,70	0,80	3,10	1,70	1	28,00
		Kontaktmaß / Contact Dimensions: 2,80; 4,80mm						
	Für / For: BMW, Ford, Jaguar, Peugeot / Citroen, Renault, Rolls Royce, VW	0800 00 18	4,50	0,70	3,10	1,70	1	28,00
		Kontaktmaß / Contact Dimensions: 2,80; 4,80mm						
	Für / For: DaimlerChrysler, VW	0800 00 19	4,50	0,70	3,10	1,70	1	28,00
		Kontaktmaß / Contact Dimensions: 2,80; 4,80mm						

800

Gabelsteckwerkzeuge
Fork Terminal Extractors

Art.-Nr. / No.	A	B	C	D	VE	EUR		
0800 00 20	5,00	0,90	3,20	1,60	1	28,00	Für / For: Alfa Romeo, Audi, DaimlerChrysler, Ford, GM, Jaguar, Peugeot / Citroen, Renault, Rolls Royce, Toyota, VW	
0800 00 21	8,30	1,00	6,30	2,50	1	28,00	Für / For: DaimlerChrysler, smart	
0800 00 22	4,70	0,60	3,10	1,70	1	28,00	Für / For: Ford, VW asymmetrische Rastzungen / asymmetrical detents	
0800 00 23	5,00	0,90	3,20	1,70	1	28,00	Für / For: Ford, VW asymmetrische Rastzungen / asymmetrical detents	
0800 00 24	5,00	1,00	3,00	1,70	1	28,00	Für / For: Audi, GM, Jaguar, Porsche, VW	
0800 00 25	3,00	0,50	2,00	0,90	1	28,00	Für / For: Ford, GM, Rolls Royce, VW	
0800 00 26	3,00	0,40	2,20	1,00	1	28,00	Für / For: Audi, Ford, GM, smart, VW	
0800 00 27	3,00	0,45	2,10	0,85	1	28,00	Für / For: Audi, DaimlerChrysler, Ford, GM, Renault, Rolls Royce, smart, VW einseitig angeschliffen / grounded on one side	
0800 00 28	2,90	0,55	1,80	0,55	1	28,00	Für / For: Ford, VW	
0800 00 29	4,60	0,80	3,00	1,70	1	28,00	Für / For: Audi, DaimlerChrysler, Ford, GM, Porsche, smart, Volvo, VW	
0800 00 30	6,00	1,20	3,60	2,45	1	28,00	Für / For: VW	
0800 00 31	6,00	1,00	4,00	1,70	1	28,00	Für / For: BMW, DaimlerChrysler, Rolls Royce, smart, VW	
0800 00 32	4,40	0,50	3,40	1,70	1	28,00	Für / For: ISO-Kontakte im Car-Hifi-Bereich/ ISO Terminals in the car hifi section	
0800 00 33	10,00	1,50	7,00	2,45	1	28,00	Für / For: BMW, Ford, Rolls Royce, VW	
0800 00 34	11,80	1,00	9,80	1,60	1	28,00	Für / For: DaimlerChrysler, Ford, GM, Jaguar, Volvo, VW abgewinkelt, Sekundärverriegelung / angle-shaped, spacers / retainers	

Weitere Größen auf Anfrage. Please ask for additional sizes.

Rundsteckwerkzeuge / Circular Terminal Extractors

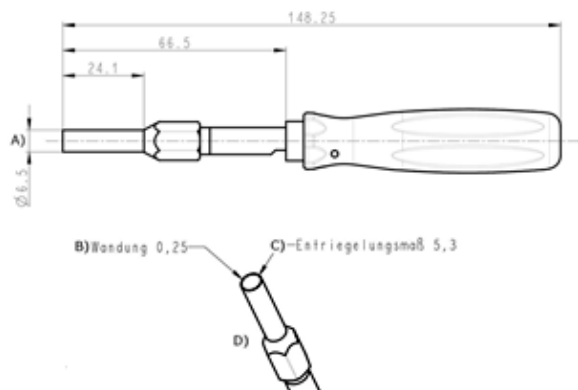









Rundsteckwerkzeuge dienen zur Entriegelung von Stift- und Buchsenkontakten, z.B. Mate-N-Lok oder D-Sub. Es gibt hierbei zwei verschiedene Entriegelungsarten, zum einen die kontaktseitige Entriegelung mit gefederten Entriegelungswerkzeugen mit Ausstoßmechanismus und zum anderen die kabelseitige Entriegelung, wobei die Hülse fest auf dem Werkzeug sitzen muss.

Round Extraction Tools are designed for the removal of pins and sockets, e.g. Mate-N-Lok and D-Sub. There are two different ways to remove the contacts, on the one hand the extraction at the mating area with spring mounted tools with push-out mechanism, on the other hand the removal at the cable side, for which the sleeve is fixed on the tool.

A = Außendurchmesser / outer diameter
 B = Wandung / wall
 C = Innendurchmesser / inner diameter
 Alle Maßangaben in mm / all measurements in mm



Rundsteckwerkzeuge Circular Terminal Extractors

800

	Art.-Nr. / No.	A	B	C	VE	EUR
 Für / For: Audi, DaimlerChrysler einseitig geöffnet / half-slotted	0800 0036	4,50	0,20	4,00	1	28,00
Kontaktmaß / Contact Dimensions: 2,50mm						
 Für / For: Audi einseitig geöffnet / half-slotted	0800 0037	6,00	0,30	5,40	1	28,00
Kontaktmaß / Contact Dimensions: 4,00mm						
 Für / For: BMW, DaimlerChrysler, Ford, GM, Jaguar, Porsche, Peugeot / Citroen, VW	0800 0038	3,30	0,20	2,90	1	28,00
Kontaktmaß / Contact Dimensions: 1,50; 1,60; 2,10mm						
 Für / For: Verschiedene Modelle, dreifach geschlitzt / Different Types, triple-slotted	0800 0039	3,50	0,40	2,70	1	28,00
Kontaktmaß / Contact Dimensions: 1,50mm						
 Für / For: BMW, DaimlerChrysler, Jaguar dreifach geschlitzt / triple-slotted	0800 0040	3,50	0,25	3,00	1	28,00
Kontaktmaß / Contact Dimensions: 1,60; 2,30mm						
 Für / For: BMW, DaimlerChrysler, Ford, Rolls Royce, VW	0800 0041	4,40	0,20	4,00	1	28,00
Kontaktmaß / Contact Dimensions: 2,50; 3,50mm						
 Für / For: BMW, Iveco, MAN, Porsche, VW	0800 0042	5,00	0,20	4,60	1	28,00
Kontaktmaß / Contact Dimensions: 3,50mm						
 Für / For: DaimlerChrysler, Iveco, MAN	0800 0043	6,50	0,25	6,00	1	28,00
Kontaktmaß / Contact Dimensions: 4,50mm						
 Für / For: DaimlerChrysler, Iveco, MAN dreifach geschlitzt / triple-slotted	0800 0044	6,00	0,25	5,50	1	28,00
Kontaktmaß / Contact Dimensions: 4,00mm						

Sondersteckwerkzeuge Special Terminal Extractors

800

	Art.-Nr. / No.	A	B	C	VE	EUR
 Für / For: Ford, Jaguar, Peugeot / Citroen, Renault, Toyota, Volvo Schräge / slope	0800 0035	1,00	1,90		1	31,00
 Für / For: DaimlerChrysler, VW	0800 0045	7,00	1,50	4,00	1	32,00
Gesamtbreite / overall width: 13,00mm						
 Für / For: BMW, DaimlerChrysler, Ford	0800 0046	3,80	2,50	3,00	1	32,00
Kontaktmaß / Contact Dimensions: 2,80mm						

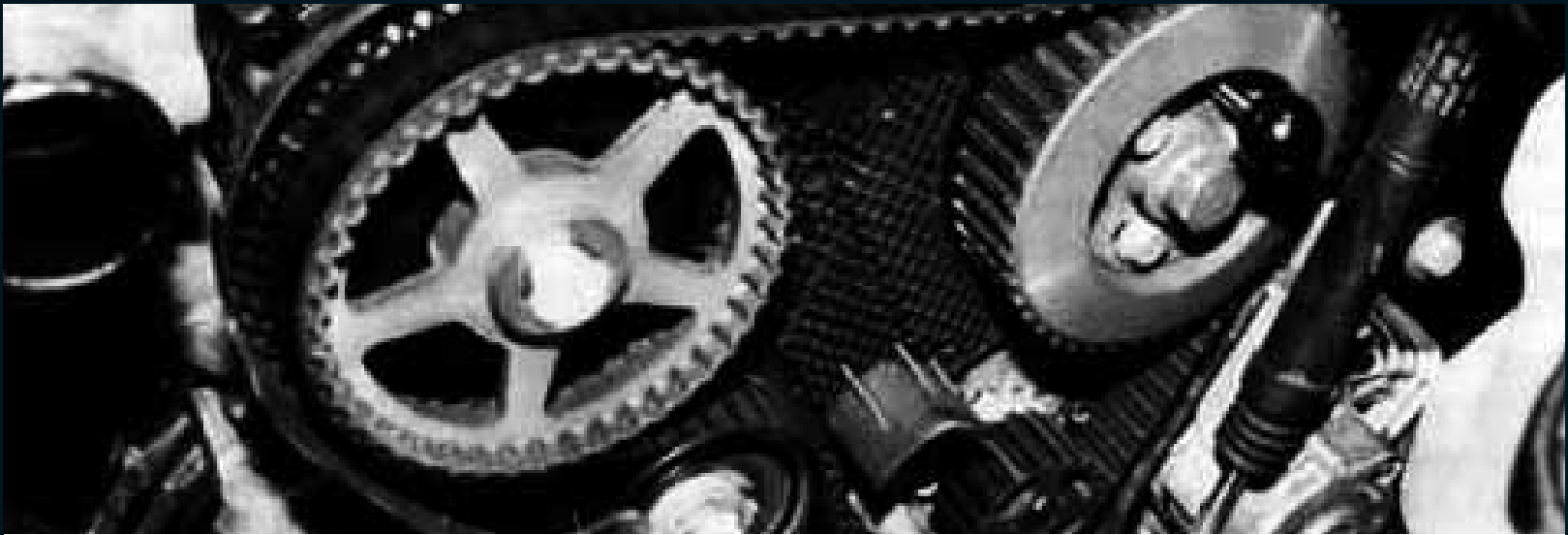

Art.-Nr. / No.	mm	g	VE	EUR	
0153 00 01	240	450	1	44,90	153
0153 00 02	255	450	1	44,90	

Riemenscheiben-Schlüssel
Belt Pulley Back-Up Wrenches

Für Wasser- und Servopumpen zum Gegenhalten beim Lösen und Anziehen der Riemenscheiben, extrem stark gekröpft, für alle Riemenscheiben mit 30mm Innentiefe bzw. 30mm breitem Flachriemen, Spezialstahl

For water- and servo pumps to counter belt pulleys for flat belts while loosening or tightening; deep offset, for all belt pulleys with 30 mm inside depth respective 30mm width flat belt, special steel

Für / For:
VW / AUDI / SEAT / SKODA (~2092-05845-255E)

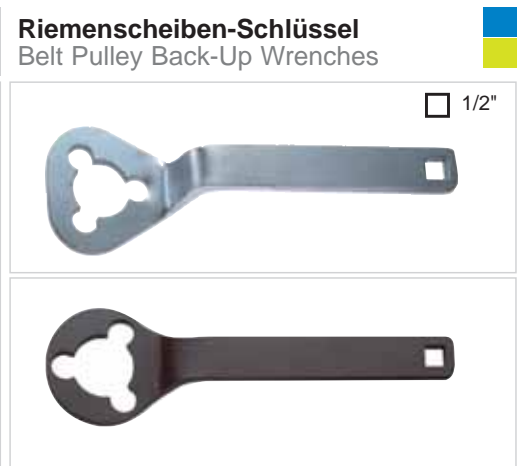

Art.-Nr. / No.	A mm	B mm	g	VE	EUR	
0731 04 00	195	88	2750	1	168,00	731/400

Riemenscheiben-Abzieher-Satz
V-Belt Pulley Puller Set

15-tlg.-Universal-Satz, für Pkw, zum Abziehen von Riemenscheiben, für Scheiben mit oder ohne Gewindelöcher, zusätzlich mit Zahnhaken (greifen in die Rillen, wenn ein Hintergreifen mit Standardhaken nicht möglich ist), in schwarzem Kunststoffkoffer

15-pcs. universal set, for vehicles, for V-Belt pulleys with or without threadhole, with groove hooks to fit into the grooves of V-Belt pulley, in black plastic case

A = Spannweite / spread
B = Spanntiefe / reach



Art.-Nr. / No.		g	VE	EUR	
4079 01 00	M10 x 60 XZN	62	1	28,00	4079/4092
4092 01 00	TX50 x 60 TORX	100	1	28,00	

Lichtmaschinen-Montagewerkzeuge
Generator assembling sockets

Zur Montage und Demontage der Freilaufriemenscheibe an der Lichtmaschine; ermöglicht die Arretierung der Lichtmaschine mit dem Schraubendrehereinsatz und gleichzeitiges Lösen / Anziehen der Riemenscheibe über den Vielzahnadapter

For installing and removing of the V-ribbed belt pulley at the built-in or dismantled generator; generator can be locked with the screwdriver socket while operating the belt pulley with the internal adapter

Für / For:
VW / AUDI / SEAT / SKODA, PORSCHE, MERCEDES-BENZ, FORD, RENAULT, VOLVO etc.



Motor allgemein / Engine

Viscolüfter- und Spezialschlüssel Special Wrench for Visco-coupling

133

Art.-Nr. / No.	mm	mm	g	VE	EUR
----------------	----	----	---	----	-----



Spezialschlüssel zum Lösen der Nabenschraube / -mutter; extra schmal gearbeitet (nur 5mm dick), um an die schwerzugänglich Stelle am Viscolüfter zu kommen; hohe Zeitersparnis bei der Montage / Demontage; Spezialstahl, tauchisolierter Griff

For reaction of the visco coupling drive when removing or installing the visco-coupling, flat type (only 5mm thickness), special steel, PVC-coated handle

Für / For:
VW / AUDI / SEAT / SKODA etc.

0133 00 01	32	280	150	1	11,90
0133 00 02	36	280	170	1	11,90

Universal-Zahnriemen-Schlüssel Universal Idler Pulley Wrench

155/1

Art.-Nr. / No.	mm	g	VE	EUR
----------------	----	---	----	-----

1/2"



Zur Einstellung des Zahnriemens an der Spannrolle, mit zwei Zapfen (Abstand 18mm; Ø2,9mm), gekröpft, verlängerbar z.B. mit Gleitgriff oder Knarre (auch zum Abwinkeln); für fast sämtliche Spannrollen; kurze Bauweise und Verlängerungsmöglichkeit ermöglichen viele Einsatzbereiche

For adjusting the toothed belt at the tensioning pulley, with 2 pins (distance 18mm; Ø2,9mm), extendable with sliding T-handle or ratchet, for mostly all belt pulleys; short design allows multipurpose application

Für / For:
VW / AUDI / SEAT / SKODA

0155 00 01	155	200	1	37,80
------------	-----	-----	---	-------

Spannschlüssel Idler Pulley Wrench

155/2

Art.-Nr. / No.	mm	mm	g	VE	EUR
----------------	----	----	---	----	-----



Zur Einstellung der automatischen Spannrolle beim Zahnriemenwechsel, nur 3mm stark, mit 12-kant SW 32mm; Spezialstahl

For expanding the automatic idler pulley on the toothed belt, slim design - only 3mm, 12-point 32mm, special steel

Für / For:
VW / AUDI / SEAT / SKODA

0155 00 02	32	180	100	1	35,00
------------	----	-----	-----	---	-------

Ringschlüssel für Einspritzpumpe Special wrench for injection pump

254

Art.-Nr. / No.	mm	mm	g	VE	EUR
----------------	----	----	---	----	-----



Einseitiger Ringschlüssel, für die Befestigungsschrauben an der Einspritzpumpe beim Ein- und Ausbau des Zahnriemens, 13mm x 165mm; Chrom-Vanadium-Stahl 31 CrV 3, matt verchromt

For the fastening screws at the injection pump, allows to replace the toothed belt or adjust the injection start; Chrome-Vanadium-Steel 31 CrV 3 (1.2208), matt chrome finish

Für / For:
VW / AUDI

0254 00 01	12	195	70	1	12,95
------------	----	-----	----	---	-------

254

Art.-Nr. / No.	mm	g	VE	EUR
0254 00 20	12	30	1	37,80



Spezialschlüssel für Turboladerverschraubungen an VW / Audi-Dieselmotoren; kurze Form, neues Modell - kein Ausbau des Kühlerausdehnungsgefäßes notwendig, von nun an sehr einfache De- und Montage, ideal für Schraube unterhalb des Turboladers

Special wrench for screwing on the turbo-charger in diesel engines of VW / AUDI; new model, short type, from now on very convenient assembling and disassembling for screw underneath the turbo-charger

Für / For:
VW / AUDI

Schlüssel Turboladerverschraubung
Special wrench for turbo charger

3/8"



2094

Art.-Nr. / No.	mm	mm	g	VE	EUR
2094 00 01	10	37	14	10	5,90
2094 00 02	15	37	14	10	5,90
2094 00 03	20	37	14	10	5,90
2094 00 04	25	37	14	10	6,10
2094 00 05	27	37	14	10	6,10
2094 00 06	30	37	14	10	6,10
2094 00 07	40	37	14	10	6,50
2094 00 08	50	37	14	10	6,50

8-tlg. Satz auf Klemmschiene /
8-pcs. set on socket rail

2094 00 10	T 10-50	37	115	1	49,50
------------	---------	----	-----	---	-------

Passend für Innen-5-Stern-Schrauben mit Zapfen (IP-Profil), für Lichtmaschine, Motorsteuerung, Luftmengenmesser, Türverkleidung usw.; Chrom-Vanadium-Stahl 31 Cr-V 3 (1.2208), matt verchromt

For the operation of inside 5-star screws with pin, for dynamo, engine control, air flow sensor etc.; Chrome-Vanadium 31 Cr-V 3 (1.2208), chrome-plated

Für / For:
VW/AUDI, FORD, VOLVO, MERCEDES BENZ (Actros, Atego) etc.

5-Stern-Schraubendreher-Einsätze
5-Star Screwdriver Sockets

1/4"



8146/3

Art.-Nr. / No.	Dosen / tins	ml	VE	EUR
8146 00 03	1	500	1	4,35
Karton / carton				
8146 00 23	10	500	1	42,00
Palette / Pallett				
8146 00 33	680	500	1	2650,00

Helles und geruchsloses Schmiermittel:
- Korrosionshemmend und intensiv haftend
- Beseitigt Quietsch- und Knarrgeräusche
- Zur Schmierung von Gleitlagern und Zahnrädern bei niedrigen und hohen Drehzahlen, auch unter Druckaufnahme geeignet (VKA-Test bis ca. 800N)
- Ideal zur Langzeitschmierung
- Hochentzündlich / abgefüllt in Deutschland

Clear and odourless lubrication agent for adv. tasks:
- Gets rid of squeaking and creaking noises
- For the lubrication of slide bearings, cogwheels for low and high revolutions and high pressure absorption (VKA test up to 800N), Made in Germany

Kriech- und Haftfett
Flowing and Binding Lubricant



8146/4

Art.-Nr. / No.	Dosen / tins	ml	VE	EUR
8146 00 04	1	500	1	8,50
Karton / carton				
8146 00 24	10	500	1	82,00
Palette / Pallett				
8146 00 34	680	500	1	4900,00

Synthetisches Universal-Schmier und Schutzmittel
- Hochwertige, widerstandsfähige Teflonschicht
- Dauerhafte Schmierwirkung
- Verhindert ein Einfrieren beweglicher Teile
- Schafft feuchtigkeitsabweisende Oberflächen
- Leichtentzündlich / abgefüllt in Deutschland

Synthetic allround lubrication and protection agent
- High quality, resistant Teflon layer
- Sustained lubrication effect
- Prevents the freezing of movable metal arts
- Ensures moisture repellent surfaces
- Protects locks, hinges, mounting parts etc.
- Flammable / Made in Germany

PTFE-Fett-Spray
PTFE-Lubrication Spray



Motorsteuerung / Engine Timing Tools

Zahnriemen-Werkzeug-Satz Toothed Belt Tool Set



910

Für Zahnriemenwechsel an 4-Zyl. TDI-Pumpe-Düse-Motoren; exaktes Arretieren des Kurbelwellen-Zahnriemenrades mit der Kurbelwellenfixierung, der Spannrollensperre und dem Arretierdorns möglich; stellt sicher, daß die Steuerzeiten des Motors bei Zahnriemenwechsel oder Motorinstandsetzung nicht verstellt werden

For drive belt exchange, e.g. on VW pump jet engines since 1999, ensures that engine timing is not altered during drive belt exchange or engine repair

Für / For:
VW / AUDI / SEAT / SKODA, FORD (Galaxy)

Art.-Nr. / No.

g VE EUR

Art.-Nr. / No.	g	VE	EUR
0910 00 01 3-tlg. / pcs.	450	1	69,00
Kurbelwellenfixierung / Crankshaft Fixing Device 0910 00 02	200	1	55,00
Spannrollensperre / Locking Plate 0910 00 03	20	1	8,00
Arretierdorn / Arresting Pin 0910 00 04	50	1	11,50

Nockenwellen-Arretierung Camshaft Adjustment Device



911/1

Zum Arretieren der Nockenwellenräder beim Zahnriemenwechsel an 4-Ventil-4-Zylinder-Einspritzmotoren; der Einsatz dieser Vorrichtung ist für eine genaue Motorsteuerung zwingend notwendig und spart Zeit und Kosten; Spezialstahl, brüniert

For adjusting the camshaft pulleys during drive belt exchange of 4-valve-4-cylinder fuel injection engines; using this device is absolutely necessary to ensure an exact engine timing and saves time and costs; special steel, black phosphated

Für / For:
VW / SKODA

Art.-Nr. / No.

g VE EUR

Art.-Nr. / No.	g	VE	EUR
0911 00 01	340	1	35,00

Nockenwellen-Arretierung Camshaft Adjustment Device



911/2/3

Zum Arretieren der Nockenwellenräder beim Zahnriemenwechsel an 2-V oder 5-V-Benzinmotoren (z.B. AUDI V6); Spezialstahl

For adjusting the camshaft pulleys during drive belt exchange of 2- or 5-valve engines (e.g. AUDI V6); special steel

Für / For:
VW / AUDI

Art.-Nr. / No.

g VE EUR

Art.-Nr. / No.	g	VE	EUR
0911 00 02 2-V	1900	1	85,00
0911 00 03 5-V	2200	1	78,00

Nockenwellen-Lineal Fixing Gauge for Camshaft



912/1

Zum Einstellen der Nockenwelle, z.B. beim Zahnriemenwechsel, mit Haltekette, Spezialstahl

To locate and fix the camshaft in the right position during drive belt exchange or engine repairs of TDI diesel engines, special steel

Für / For:
VW / AUDI (2,5 TDI V6, 3,3 TDI V8)

Art.-Nr. / No.

g VE EUR

Art.-Nr. / No.	g	VE	EUR
0912 00 01	350	1	25,00

Art.-Nr. / No.	 g	 VE	EUR	912/2
0912 00 02	350	1	65,00	





Zum Justieren der Nockenwelle, z. B. bei Zahnriemenwechsel oder Arbeiten an der Motorsteuerung; anstelle der Vakuumpumpe einsetzen - Demontage des Ventildeckels entfällt; vermeidet Beschädigungen der aufvulkanisierten Dichtung oder des Ventildeckels, kein Nachdrehen der Nockenwelle

Camshaft Setting Bracket, timing adjustment even when vacuum pump and camshaft are still in place; just offer the camshaft setting bracket to the camshaft slot by sliding it along the dowel screws

Für / For:
VW / AUDI / SEAT / SKODA

Nockenwellen-Lineal Camshaft Adjustment Device



Art.-Nr. / No.	 g	 VE	EUR	912/3/4
0912 00 03	150	1	46,00	
0912 00 04	70	1	25,00	



Zum Justieren der Nockenwelle in OT-Stellung, z. B. bei Zahnriemenwechsel oder Arbeiten an der Motorsteuerung; einfach am hinteren Nockenwellenende einschieben; Spezialstahl

For adjusting the camshaft pulleys during drive belt exchange; just place tool behind the camshaft, special steel

Für / For:
VW / AUDI / SEAT / SKODA

Nockenwellen-Lineale Camshaft Adjustment Devices



Art.-Nr. / No.	 g	 VE	EUR	912/5
0912 00 05	75	1	25,00	

Zum Arretieren der Kurbelwelle bei VW / AUDI V6-Benzin oder V6- / V8-Diesel-Motoren, z.B. während des Zahnriemenwechsels oder bei Motorarbeiten, Spezialstahl

For adjusting the camshaft pulleys during drive belt exchange in the TDC position, used in conjunction with tools T 40011, T 40028, and T 40030; special steel

Für / For:
VW / SKODA / AUDI (2,5 TDI; V6; A8 3,3; TDI V8)

Fixierschraube / Arretierdorn Crank Locking Pin



Art.-Nr. / No.	 M	 mm	 g	 VE	EUR	4079
4079 90 13	M 16	80	95	1	9,20	

Spezialeinsatz zur De- und Montage der Befestigungsschrauben für das Antriebsrad der Nockenwelle; auch für den Ein- und Ausbau des hinteren Bremssattels (VW Touareg); für B&S-XZN - Schrauben, für Handbetätigung, Chrom-Vanadium-Stahl 31 CrV 3, matt verchromt

Special Socket for pulling the wheel hubs / wheel bearing units off stub axle; for B&S-XZN screws, for manual drive, Chrome-Vanadium-Steel 31 CrV 3 (1.2208), matt chrome finish

Für / For:
VW / AUDI (Touareg / Phaeton V10) etc.

Spezialeinsatz XZN für Nockenwelle Special Socket XZN for camshaft



Motorsteuerung / Engine Timing Tools

Satz Arretierdorne Locking Pin Set for Belt Tensioner



912/6

Satz Arretierdorne: Absteckstift für reibgedämpftes Spannsystem - Pumpe-Düse Motoren, Arretierdorn für das Zahnriemenspannelement sowie Arretierdorn für das Spannelement zur Demontage des Keilrippenriemens

Set of 3 locking pins for holding the tension on the camshaft belt and serpentine (auxiliary) belts on VAG engines

Für / For:
VW / AUDI / SKODA / SEAT

Art.-Nr. / No.		g	VE	EUR
0912 00 06	3-tlg. / pcs.	350	1	9,95

Universal-Gegenhalteschlüssel Camshaft Pulley Holding Tool

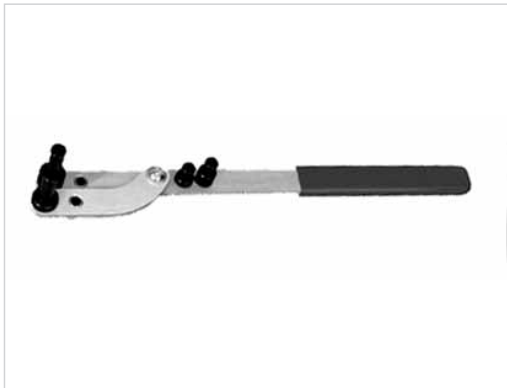

913

Universal-Schlüssel zum Gegenhalten der Zahnriemenräder an der Nockenwelle, Einspritzpumpe etc., für alle gelochten Zahnriemenräder mit einem Lochdurchmesser von mindestens 14mm; Spezialstahl

This universal tool can be used to hold the pulleys on Camshafts, Injection Pumps etc. when loosening the centre retaining bolt; fits timing pulleys with a hole diameter of 14mm; rotates timing gear to reach TDC

Für / For:
VW / AUDI / SKODA / SEAT, FORD, OPEL, PEUGEOT, CITROEN, RENAULT, VOLVO etc.

Art.-Nr. / No.	mm	mm	g	VE	EUR
0913 00 01	410	14	350	1	49,95

Universal-Arretierwerkzeug Timing Gear Clamp

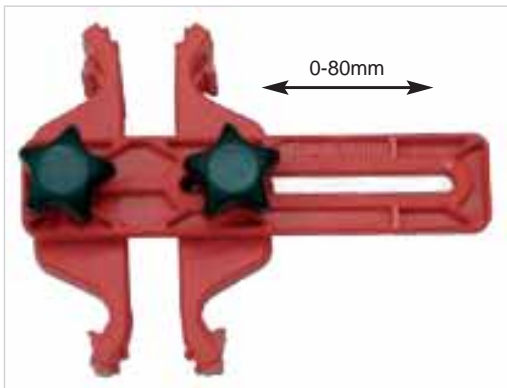

914

Zum Arretieren der Nockenwellenräder bei Zahnriemenwechsel, Motorarbeiten usw., für doppelte Nockenwellen, ermöglicht die Reparatur nur durch eine Person, spart Arbeitszeit und Kosten, schützt vor Motorschäden infolge falscher Steuerzeiten, universell einsetzbar für viele Fahrzeugtypen, Kunststoff

Allows belt replacement to be carried out by one person, reduces repair time and prevents engine damage caused by mis-timing; can be used on twin cam and quad cam engines to hold valve timing during belt replacement; patented uni-fit design suits a large range of varying cam gear; friction locking system allows infinite locking positions, special polymer

Art.-Nr. / No.		g	VE	EUR
0914 00 01		350	1	65,90

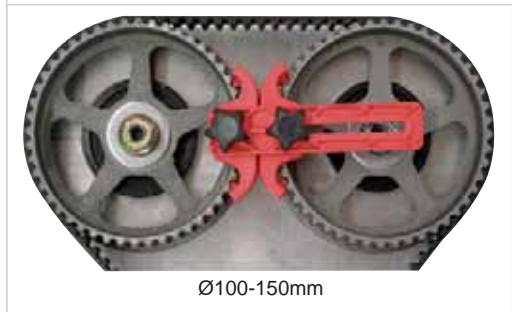

Zahnriemen-Spannungsprüfer Cam Belt Tension Gauge



915

Zum Prüfen und Einstellen der Zahnriemen-Vorspannung, vermeidet Schäden z.B. an der Wasserpumpe und am Ventiltrieb; reduziert Laufgeräusche des Zahnriemens; einsetzbar für nahezu alle Fahrzeugtypen, insbesondere für Diesel-Motoren

Special tensioning gauge, can be used to adjust the tension on the cam belt where the movement of the timing belt is measured by load; suitable for belts with various widths, e.g. diesel engines

Art.-Nr. / No.	mm	g	VE	EUR
0915 00 01	250	350	1	69,00

Art.-Nr. / No.	A		B		g	VE	EUR	731/350
	mm	mm	mm	mm				
0731 03 50	130	44	900	1	122,00			

A = Spannweite / spread
 B = Spanntiefe / reach

Zum Abziehen der Nockenwellenräder, mit vier Spezialhaken, Spezialstahl, verzinkt
 For pulling the camshaft wheels, with 4 special legs, special steel, zinc plated

Für / For:
 VW / AUDI (TDI 4, 6 , 8 ZYLINDER; Otto V6, V8)

Nockenwellen-Abzieher

Puller for Camshaft Wheels

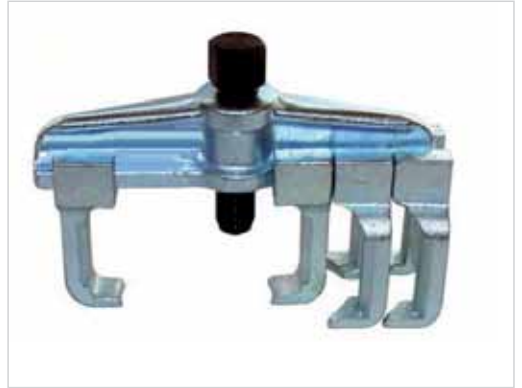

Art.-Nr. / No.	mm		g	VE	EUR	916
	mm	mm				
0916 00 01	32	10	200	1	25,00	

Universal-Werkzeug, zum Blockieren des Motors bei ausgebautem Getriebe; das Werkzeug greift zum Blockieren in den Starterzahnkranz des Schwungrades; Langloch Ø10 x 32mm; Spezialstahl
 Universal tool, for locking the flywheel when the gearbox is dismantled, Ø10 x 32mm, special steel

Schwungrad-Blockierwerkzeug

Flywheel Locking Tool



Art.-Nr. / No.	mm		g	VE	EUR	920
	mm	mm				
0920 00 01	900	5,8	500	1	595,00	

Profi-Fiberglas-Endoskop mit 7.400 Pixel Hochoauflösung (!):
 - Abnehmbare Xenon-Taschenlampe
 - Flexibles halbstarres Kabel, wasser- und hitzefest
 - Extrem kleiner Wendekreis
 - Klemmspiegel
 - Sehfeld: 40°
 Professional Fibreglas Endoscope with 7,400 pixel high resolution:
 - Xenon detachable flashlight
 - Obedient flexible shaft, water & abrasive resistant
 - Clip-on mirror
 - Field of view: 40°

Professionelles Fiberglas-Endoskop

Fibreglas Endoscope

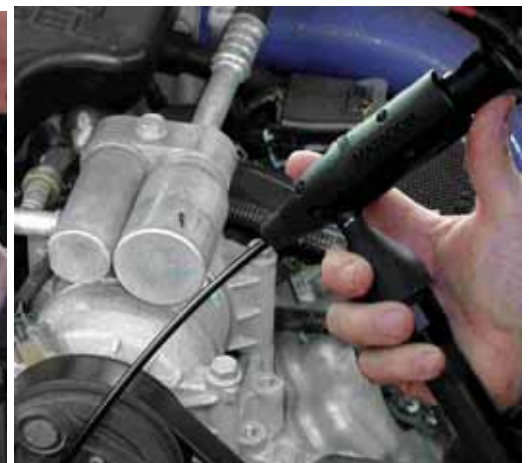

Ventildichtring-Zange
Valve Ring Plier



418

Zum Abziehen von Ventilschaftdichtungen an 2-Ventiler-Motoren, gerade, querverzahnt, gehärtete Backen, vernickelt

For removing valve stem seals on 2-valve engines, straight, serrated, hardened jaws, nickel plated

Für / For:
VW, AUDI, FORD, OPEL, NISSAN etc.

Art.-Nr. / No.	mm	g	VE	EUR
----------------	----	---	----	-----

0418 00 01	250	350	1	38,20
------------	-----	-----	---	-------

Ventileinschleifer
Suction Valve Grinder Stocks



419

Zum Einschleifen der Ventile, beidseitig mit Saugnapf, mit Holzschaft

For grinding the valve seating; both ends with rubber cup, with wooden shaft

Art.-Nr. / No.	mm	mm	g	VE	EUR
----------------	----	----	---	----	-----

0419 00 01	16x21	200	63	1	1,95
0419 00 02	28x34	200	63	1	2,35

Kolbenringzangen
Piston Ring Pliers



565

Zum Abnehmen und Auflegen von Kolbenringen, Spezialstahl, vernickelt, mit Kunststoff-Griffhüllen

For removing and mounting piston rings, special steel, nickel plated, with plastic handles

Art.-Nr. / No.	mm / "	mm / "	g	VE	EUR
----------------	--------	--------	---	----	-----

0565 00 01	50-100 2-4"	200 8"	230	1	21,90
0565 00 02	90-140 3.1/2-5.1/2"	240 9.1/2"	370	1	29,80

Kolbenring-Spannbänder
Piston Ring Compressors



567

Zum Einsetzen von Kolben und Ringen in den Zylinder, stufenlose Feststellung, mit Spannschlüssel, hochfester Federbandstahl

For inserting the piston with ring into the cylinder, stepless adjustment, with key, high grade tool steel

Art.-Nr. / No.	mm / "	mm	g	VE	EUR
----------------	--------	----	---	----	-----

0567 00 01	40 - 75 1.1/2 - 3"	50	140	1	14,10
0567 00 02	60 - 125 2.1/4 - 5"	80	320	1	19,20
0567 00 03	90 - 175 3.1/2 - 7"	80	360	1	22,90
0567 00 04	90 - 175 3.1/2 - 7"	165	680	1	38,10

Art.-Nr. / No.	↔ mm	⚖ g	📦 VE	EUR	262
0262 00 01	220	460	1	24,95	<p>Für die Einfüll- und Ablassschrauben an Getriebe, Differential und Ölwanne, mit verschiedenen Abmessungen (8,7; 9,5; 10,5; 11,5; 13; 6,8; 15,2; 16,5; 19,7mm); Spezialstahl, matt verchromt</p> <p>For the oil filter and oil drain plugs on gearbox, differential and oil pan; with different dimensions (8,7; 9,5; 10,5; 11,5; 13; 6,8; 15,2; 16,5; 19,7mm); special steel, matt chrome finish</p>

Universal-Öldienstschlüssel Universal Oil Service Wrench



Art.-Nr. / No.	⊘ mm	↔ mm	⚖ g	📦 VE	EUR	265/266
0265 00 01	14 x 17	240	230	1	24,00	<p>Zum Lösen und Anziehen der Ölstopfen am M 8-Getriebe (Typ 100, 110, 115-117, 615-617; -MB-Nr. 000 589 24 07 00)</p> <p>To loose and tight the filler plug and oil drain on M 8 gearbox (Types 100, 110, 115-117, 615-617; -MB-Nr. 000 589 24 07 00)</p>
0266 00 01	8 x 10	270	435	10	16,50	

Spezial-Öldienstschlüssel Special Drain Plug Wrenches



Art.-Nr. / No.	↔ mm	⚖ g	📦 VE	EUR	425
0425 00 01	max. 240	250	1	24,95	<p>Für Ölfilter und sonstige Rundverschraubungen, mit verstellbarem Gewebeband aus Baumwolle, gummi-beschichtet, rutschfest, Griff kunststoffbeschichtet</p> <p>For oil filters and other round shaped bodies, with cotton textile tape, rubber coated, nonskidding, cushion grip handle</p>
0425 00 03	max. 650	280	1	29,95	
Ersatzband / Spare strap					
0425 00 02	max. 240	30	1	8,50	
0425 00 04	max. 650	55	1	10,50	



Universal Ölfilter-Bandschlüssel Universal Strap Wrenches



Art.-Nr. / No.	↔ mm	⚖ g	📦 VE	EUR	426
0426 00 01	max. 240	400	1	39,95	<p>Für Ölfilter und sonstige Rundverschraubungen, mit geschmiedetem Handgriff, besonders für Nfz / Landmaschinen geeignet; mit verstellbarem Gewebeband aus Baumwolle, gummi-beschichtet, rutschfest; Chrom-Vanadium-Stahl 31 CrV 3, matt verchromt</p> <p>For oil filters and other round shaped bodies, with forged handle, especially for commercial vehicles and agricultural machinery; with cotton textile tape, rubber coated, nonskidding; Chrome-Vanadium-Steel 31 CrV 3 (1.2208), matt chrome finish</p>
0426 00 03	max. 800	450	1	45,95	
Ersatzband / Spare strap					
0426 00 02	max. 240	40	1	8,50	
0426 00 04	max. 800	90	1	12,50	

Universal Ölfilter-Bandschlüssel Universal Strap Wrenches



Universal-Ölfilter-Schlüssel
Universal Oil Filter Wrench



428/3

Zum Lösen von schwer zugänglichen Ölfiltern;
Spezialstahl, brüniert

For loosening oil filters, special steel, black phosphated

Art.-Nr. / No.	∅ mm	g	VE	EUR
----------------	---------	---	----	-----

0428 00 03	80 – 130	680	1	28,20
------------	----------	-----	---	-------

Universal-Ölfilter-Schlüssel
Universal Oil Filter Wrench



428/5

Mit Links- und Rechtsgang. Antriebe Außen-6-kant SW 19mm und Innen-4-kant 3/8"; Spannbereich ca. Ø 65-140mm. Die drei "Arme" aus speziellem, hochfestem Stahl haben einen rechteckigen Querschnitt und krallen sich dadurch insbesondere beim Lösen der Ölfilter in das Blech, was ein Abrutschen unmöglich macht; Spezialstahl, brüniert

Right- and left hand tightening, outside hexagon drive 19mm, inside square drive 3/8", cap. from diameter 65-140mm. The three arms made from special high strength steel, with rectangular cross-section, therefore clawing especially during un-tighten of the oil filter into the metal sheet, no slip off; special steel

Art.-Nr. / No.	∅ mm	g	VE	EUR
----------------	---------	---	----	-----

0428 00 05	65-140	350	1	54,00
------------	--------	-----	---	-------



Kartuschen-Schlüssel Nfz
Cartridge Wrench for trucks



428/145

Besonders stabile Ausführung, zum Lösen von Granulat-Kartuschen bei Nutzfahrzeugen mit Druckluft-trockner, negative Armstellung, Spezialstahl, brüniert

Heavy pattern, for loosening the granulates cartridge on commercial vehicles with compressed air dryer; special steel, black phosphated

Für / For:
MERCEDES BENZ (~MB 655 589 0061 00), MAN (~8099606-0307)

Art.-Nr. / No.	∅ mm	mm	g	VE	EUR
----------------	---------	----	---	----	-----

0428 01 45	80 – 150	85	940	1	179,00
------------	----------	----	-----	---	--------



Ölfilter-Kettenschlüssel
Oil Filter Chain Wrench







470

Passend für alle PKW, mit extrem reissfester Kette, sehr hochwertige Ausführung für eine lange Lebensdauer im täglichen Werkstatteinsatz; mit 32 Ketten-gliedern, 1/2"-Antrieb

Heavy duty, can be used on pipe and fittings with the force applied in either direction on the handle; fits for all car oil filters; 32 chain links, with 1/2" square drive

Art.-Nr. / No.	∅ mm	mm	g	VE	EUR
----------------	---------	----	---	----	-----

0470 00 01	50 – 100	235	320	1	26,80
------------	----------	-----	-----	---	-------

Art.-Nr. / No.	 mm	 mm	 g	 VE	EUR	429
0429 00 01	14	74	120	1	12,90	Für Ölfilter mit Ø 74mm, 14-kt., für die gängigsten Ölfilterpatronen passend For oil filters with Ø 74mm, 14-pt., for most cars VW/AUDI/SEAT/SKODA, MERCEDES BENZ, OPEL, PORSCHE, FORD, PEUGEOT, RENAULT, FIAT, LANCIA, TOYOTA, NISSAN, MAZDA, SUZUKI etc.
0429 00 09	14	74	165	1	16,90	Besonders flache Form, für Ölfilter mit Ø 74mm, 14-kt., für die gängigsten Ölfilterpatronen passend Flat type, for oil filters with Ø 74mm, 14-pt. MANN-, KNECHT-, OPEL Longlife-Filter / -filters, VW/AUDI/SEAT/SKODA, MERCEDES BENZ, OPEL, PORSCHE, FORD, FIAT, TOYOTA etc.
0429 00 05 0429 00 04	32 36	50	165	1	21,00	Zum Ein- und Ausbau des Ölfilterdeckels, 6-kt., Chrom-Vanadium-Stahl 31 CrV 3, matt verchromt For mounting and dismounting of the top of the oil filter; 6-pt., CV steel 1.2208, matt chrome finish 32mm: VW/AUDI (Passat), OPEL (Astra, Corsa) 36mm: MERCEDES BENZ (116), BMW; OPEL, VW
0429 00 08	12	76	150	1	20,30	Für Ölfilter mit 12 Rillen, Ø 76mm, kein Ausbau des Ansaugrohrs notwendig For oil filters with 12 grooves, Ø 76mm; no dismounting of suction tube necessary VW/AUDI/SEAT/SKODA (Purflux-Filter LS 918), MERCEDES BENZ 6 Zylinder-Motoren M 102/103

Ölfilter-Einsätze Oil Filter Sockets



Art.-Nr. / No.	 mm	 mm	 g	 VE	EUR	429/10
0429 00 10	27	400	700	1	29,50	Spezienschlüssel zum Ein- und Ausbau des Ölfilters der Haldex-Kupplung, für Allrad-Fahrzeuge, Spezialstahl, matt verchromt Angled ring spanner for loosening and tightening Haldex coupling oil filters, for 4-wheel drive cars, special steel, matt chrome finish Für / For: VW (Bora, Golf IV / V, Sharan, Touran) / AUDI (TT)

Ölfilter-Schlüssel Haldex-Kupplung Oil Filter Wrench for Haldex coupler



Art.-Nr. / No.	 mm	 g	 VE	EUR	4086
4086 00 01	85	80	10	15,00	Für Ölfilter an VW/AUDI-Dieselmotoren (Lösen mit Schlagschrauber, Anziehen mit Drehmomentschlüssel), Chrom-Vanadium-Stahl 31 CrV 3, matt verchromt For oil filter on VW/AUDI-diesel engines, loose with impact wrench, tight with torque wrench, Chrome-Vanadium-Steel 31 CrV 3 (1.2208), matt chrome finish Für / For: VW / AUDI

Spezial-Ölfilter-Einsatz VW Special Oil Filter Socket VW



Zünd- und Glühkerzen / Spark and Glow Plugs

Zündkerzenschlüssel Spark Plug Wrenches

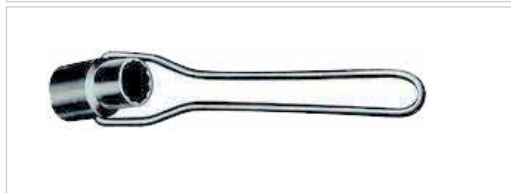

366

Standard-Zündkerzenschlüssel, für Zündkerzen mit 16mm (5/8")-Schlüsselweite, Chrom-Vanadium-Stahl 31 CrV 3, matt verchromt

Universal spark plug wrench, for most applications, for 16mm (=5/8") spark plugs, Chrome-Vanadium-Steel 31 CrV 3 (1.2208), matt chrome finish

Art.-Nr. / No.	mm	mm	g	VE	EUR
----------------	----	----	---	----	-----

Mit Drehstift / with tommy bar 0366 00 01	16x 20,8	230	290	5	9,95
--	----------	-----	-----	---	------

Mit Bügel / with handle 0366 00 02	16x 20,8	215	200	5	11,50
---------------------------------------	----------	-----	-----	---	-------

Zündkerzenschlüssel Spark Plug Wrench

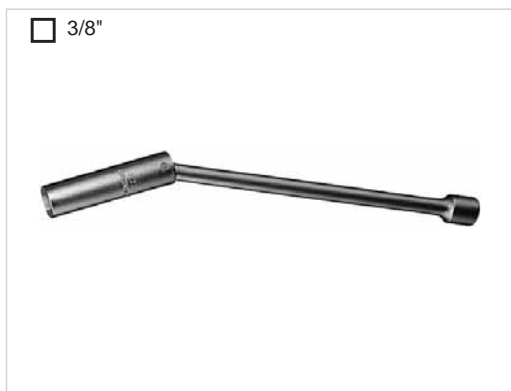

367

Mit Kugelgelenk für schwer zugängliche Zündkerzen, mit 16mm (5/8")-Schlüsselweite, Chrom-Vanadium-Stahl 31 CrV 3, matt verchromt

With ball joint, for difficult accessible spark plugs (16mm - 5/8"), Chrome-Vanadium-Steel 31 CrV 3 (1.2208), matt chrome finish

Art.-Nr. / No.	mm	mm	g	VE	EUR
----------------	----	----	---	----	-----

0367 00 16	16 = 5/8"	270	285	5	38,00
------------	-----------	-----	-----	---	-------

Für / For:
VW/AUDI/SEAT, BMW, FORD, OPEL, ROVER,
RENAULT, HONDA, MAZDA, NISSAN etc.

Zündkerzenschlüssel Spark Plug Wrench



372

Extra lange Ausführung, mit Haltegummi, für Zündkerzen mit 16mm (5/8")-Schlüsselweite, mit Loch für Drehstift, Chrom-Vanadium-Stahl 31 CrV 3, matt verchromt

Long type, with rubber ply, for 16mm (=5/8") spark plugs, with hole for tommy bar, Chrome-Vanadium-Steel 31 CrV 3 (1.2208), matt chrome finish

Art.-Nr. / No.	mm	mm	g	VE	EUR
----------------	----	----	---	----	-----

0372 00 02	16=5/8	270	180	1	11,50
------------	--------	-----	-----	---	-------

Für / For:
VW/AUDI (16V), BMW, FORD, OPEL, ROVER,
RENAULT, HONDA, MAZDA, NISSAN etc.

Zündkerzenschlüssel Spark Plug Wrenches



373 / 383

Zum mühelosen Zündkerzenwechsel an französischen Fahrzeugen, für Zündkerzen mit 14mm-Schlüsselweite, mit Gummihalterung und Loch für Drehstift, Chrom-Vanadium-Stahl 31 CrV 3, matt verchromt

For easy removing of spark plugs in French cars, for 14mm spark plugs, with rubber mounting, Chrome-Vanadium-Steel 31 CrV 3 (1.2208), matt chrome finish

Art.-Nr. / No.	mm	mm	g	VE	EUR
----------------	----	----	---	----	-----

0373 00 01	14	90	50	5	15,90
------------	----	----	----	---	-------

0383 00 02	14	250	145	5	20,20
------------	----	-----	-----	---	-------

Für / For:
RENAULT, PEUGEOT, CITROEN

Art.-Nr. / No.	mm	"	g	VE	EUR	
0568 20 01	205	8	230	5	25,30	568

Zum Abziehen und Aufstecken von Zündkerzensteckern, insbesondere für Wärmeschutzstecker, mit 2-Komponenten-Griff, brüniert

For installing and removing of spark plug sockets, esp. suitable for hot terminals, with dual compound handle, black

Für / For:
VW/AUDI, OPEL, PORSCHE etc.



Zündkerzenstecker-Zange

Spark Plug Pliers



Art.-Nr. / No.	mm	g	VE	EUR	
0569 00 01	200	220	5	35,00	569/1

Zum Abziehen und Aufstecken von geraden Zündkerzensteckern, insbesondere am betriebswarmem Motor, verchromt

For installing and removing of spark plug sockets, especially on hot engines, chrome plated

Für / For:
MERCEDES-BENZ etc

Zündkerzenstecker-Zange

Spark Plug Pliers



Art.-Nr. / No.	mm	g	VE	EUR	
0569 00 02	300	260	1	38,90	569/2

Abziehwerkzeug für Zündkerzen-Stecker mit ca. 110mm langem Kunststoff-Griff und einer Gesamtlänge von ca. 300mm; für sehr tief liegende Stecker mit Metallmantel geeignet, Kunststoffgriff, matt verchromt

Spark Plug Socket Extractor, 110mm, total length 300mm, suitable for very low lying metal covered spark plugs, with plastic handle, matt chrome finish

Für / For:
VW/AUDI/SEAT/SKODA, FORD, MERCEDES



Zündkerzenabzieher

Spark Plug Socket Extractor

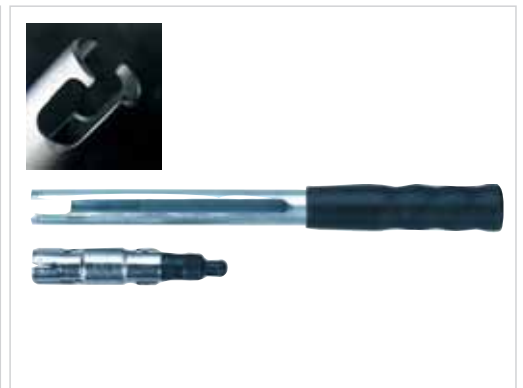

Art.-Nr. / No.	mm	g	VE	EUR	
0781 00 01	150	20	10	2,30	781

Zum Reinigen von Elektroden und Kontakten an Zündkerzen, gewellte Messing-Drahtborsten, 3-reihig, Besatzhöhe 15mm, mit Holzgriff

For cleaning of electrodes and contacts on spark plugs, special corrugated brass wire bristles, 3 rows, trim size 15mm, wooden body

Zündkerzenbürste

Spark Plug Brush



Zünd- und Glühkerzen / Spark and Glow Plugs

Zündkerzen-Einsätze Spark Plug Sockets

3/8"



3081

Für den Zündkerzenwechsel, mit Gummi oder Dauermagnet, lange Ausführung, Chrom-Vanadium-Stahl 31 CrV 3, matt verchromt

For changing of spark plugs, with rubber or permanent magnet, long type, Chrome-Vanadium-Steel 31 CrV 3 (1.2208), matt chrome finish

Art.-Nr. / No. mm mm g VE EUR

Mit Gummi / with rubber					
3081 00 04	16 - 5/8	80	160	10	13,75
3081 00 05	18 - 11/16	80	170	10	13,75
3081 00 02	20,8 - 13/16	80	185	10	13,75
Mit Magnet / with permanent magnet					
3081 00 01	16 - 5/8	80	160	10	16,45
3081 00 03	20,8 - 13/16	80	185	10	16,45

Zündkerzen-Einsätze Spark Plug Sockets

1/2"



4081

Für den Zündkerzenwechsel, mit Gummi oder Dauermagnet, lange Ausführung, Chrom-Vanadium-Stahl 31 CrV 3, matt verchromt

For changing of spark plugs, with rubber or permanent magnet, long type, Chrome-Vanadium-Steel 31 CrV 3 (1.2208), matt chrome finish

Art.-Nr. / No. mm mm g VE EUR

Mit Gummi / with rubber					
4081 00 01	16 - 5/8	65	100	10	13,50
4081 00 04	18 - 11/16	68	150	10	13,80
4081 00 03	20,8 - 13/16	68	160	10	14,50
Mit Magnet / with permanent magnet					
4081 00 07	16 - 5/8	65	100	10	16,90
4081 00 06	20,8 - 13/16	68	160	10	17,90

Glühkerzen-Gelenkeinsätze Glow Plug Sockets

3/8"



3096

Zum Aus- und Einbau von Glühkerzen, mit Kugelmutter zum sicheren Halt der Glühkerze; mit Kardangeln für maximalen Schwenkwinkel, Chrom-Vanadium-Stahl 31 CrV 3, matt verchromt

For installing and removing glow plugs, with ball clamping to hold the glow plug, with universal joint, Chrome-Vanadium-Steel 31 CrV 3 (1.2208), matt chrome finish

Art.-Nr. / No. mm mm g VE EUR

3096 00 01	8	89	80	1	24,95
3096 00 02	9	89	80	1	24,95
3096 00 03	10	70	80	1	24,95
3096 00 04	12	70	80	1	24,95
3096 00 05	9	50	40	1	21,50

Für / For:
VW / AUDI (TDi), MERCEDES BENZ (CDI) etc.

3/8"-Glühkerzensatz MTS 3/8"-Glow Plug Socket Set

3/8"



3096 ModuFlex S

Zum Aus- und Einbau von Glühkerzen, 8mm für die Stromschienen-Verschraubung, 12mm für die Glühkerzen; insbesondere für Glühkerzen, die zwischen Motorblock und Diesel-Einspritzpumpe liegen, Spezialstahl, matt verchromt





For installing and removing glow plugs, 8mm for conductor rail screws, 12mm for glow plugs, esp. for glow plugs between the engine unit and the diesel injection pump, special steel, matt chrome finish

Art.-Nr. / No. g VE EUR

3096 60 10	5-tlg. / pcs.	300	1	115,00
------------	---------------	-----	---	--------

Inhalt / Contents:
8x89, 9x89, 10x70, 12x70, 9x50mm

Für / For:
VW / AUDI (TDi), MERCEDES BENZ (CDI) etc.

Art.-Nr. / No.	 mm	 mm	 g	 VE	EUR	3096/10
----------------	--	--	---	--	-----	---------

3096 00 10	8	190	300	1	65,00	
3096 00 11	10	190	300	1	67,00	

Zum sicheren Ausdrehen / Ausziehen von besonders festsitzenden Glühkerzen; reduziert die Gefahr abgerissener Glühkerzen und verhindert somit die Gewindereparatur; Chrom-Vanadium-Stahl 31 CrV 3, matt verchromt

For safe installing and removing of glow plugs, reduces the risk of broken glow plugs and holds the glow plug safe; Chrome-Vanadium-Steel 31 CrV 3 (1.2208), matt chrome finish

Werkzeug erreicht auch tiefliegende Glühkerzen
Tool fits into narrow spaces



Glühkerze wird im Werkzeug fixiert
Glow Plug will be fixed inside the tool



Spezial-Glühkerzenauszieher Special Glow Plug Tool

3/8"



Fixierte Glühkerze lässt sich einfach herausdrehen
Fixed Glow Plug can be removed easily



Art.-Nr. / No.	 mm	 mm	 g	 VE	EUR	3096/20
----------------	--	--	---	--	-----	---------

3096 00 20	8x12	255	160	1	34,50	
------------	------	-----	-----	---	-------	--

Speziell für den Aus- und Einbau schlecht erreichbarer Glühkerzen (z.B. hinter der Einspritzpumpe); SW 8mm für die Stromschienenverschraubung - SW 12mm für die Glühkerzen; leicht gekröpft, 6-kant, Chrom-Vanadium-Stahl 31 CrV 3, matt verchromt

Especially for installing and removing of deeply located glow plugs in areas with restricted access; 8mm for conductor rail screws - 12mm for glow plugs; offset, 6-pt., Chrome-Vanadium-Steel 31 CrV 3 (1.2208), matt chrome finish

Für / For:
VW / AUDI (TDi), MERCEDES BENZ (CDI) etc.

Glühkerzen-Ringratschenschlüssel Ratchet Wrench for Glow Plugs



Art.-Nr. / No.	 g	 VE	EUR	3096/30
----------------	---	--	-----	---------

3096 00 30	18-tlg. / pcs.	250	1	98,00	
------------	----------------	-----	---	-------	--

Zum Instandsetzen beschädigter bzw. zum Erneuern zerstörter Glühkerzengewinde; mit Gewindevorbohrer (M10x1,00), Gewindebohrer (M12x1,00) und 16 Gewindeeinsätzen M10/12x1,00; in Holzkassette

For the repair of glow plug threads in aluminium cylinder heads; with special screw taps to change the M10 into a M12 thread, in wooden case

3096 00 31	10-tlg. / pcs.	20	1	29,95	
------------	----------------	----	---	-------	--

Ersatzgewindeeinsätze, M10/M12x1,00x14mm / Spare thread inserts, M10/M12x1,00x14mm

Für / For:
VW / AUDI (TDi), MERCEDES BENZ (CDI) etc.

Glühkerzen-Gewindereparaturset Glow Plug Thread Repair Kit



Düsen / Einspritzleitungen / Injection Nozzles and Pipes

Injektorschlüssel Injection Pipe Spanners

□ 1/2"



253

Für Überwurfmutter an Einspritzleitungen, mit Anschlag zur Vermeidung des Ab- oder Durchrutschens auf der Überwurfmutter; insbesondere für Überwurfmutter von Diesel- bzw. Einspritzleitungen bei PKW und LKW geeignet; extra lang; 12-kant; Spezialstahl, brüniert

Injection Pipe Spanners, with cover on the ring side, no slip off or slip through, especially for flare nuts on diesel engines injection lines, for cars and trucks. Long pattern: 1/2" square drive, 12-point, black phosphated

Art.-Nr. / No.	mm	mm	g	VE	EUR
0253 00 03	17	100	130	1	57,50
0253 00 04	18	100	140	1	58,50
0253 00 05	19	100	150	1	59,00

Leckölzange für Rücklaufleitungen Leak-Off Pliers



537

Zum Abziehen bzw. Aufstecken von Kraftstoff-Rücklaufleitungen an Einspritzdüsen bei Dieselmotoren; gekröpft, mit Seitenschneider, Kunststoffgriff mit Gleitschutz, Spezialstahl, matt verchromt

For installing and removing fuel return lines on injector nozzles, esp. for diesel engines; flat round, cranked with side cutter, with insulated handle with slip guard, special steel, matt chrome finish

Für / For:
VW / AUDI, MERCEDES BENZ, FORD, OPEL,
VOLVO, PEUGEOT, DAIHATSU, MAZDA, TOYOTA

Art.-Nr. / No.	mm	g	VE	EUR
0537 00 01	200	220	1	31,50

Schnellanschlusszange Leak Oil Pliers



538

Zum Entriegeln und Aufstecken von Kraftstoff-Leitungskupplungen, z.B. beim Kraftstofffilterwechsel, tauchisolierter Griff, Spezialstahl, matt verchromt

For installing and removing fuel return lines on injector connection on fuel pipes, plastic coated handle, special steel, matt chrome finish

Für / For:
VW / AUDI, MERCEDES BENZ, FORD, OPEL,
VOLVO, PEUGEOT, DAIHATSU, MAZDA, TOYOTA

Art.-Nr. / No.	mm	g	VE	EUR
0538 00 01	155	180	1	44,50

Einsätze für Einspritzdüsen Sockets for injection nozzles

□ 1/2"







4081

Für Einspritzdüsen an Dieselmotoren, lange Ausführung, 4081/30 besonders hinterdreht zur Aufnahme der Rücklaufanschlüsse, 12-kant, Chrom-Vanadium-Stahl 31 CrV 3, matt verchromt

For injection nozzles on diesel engines, long type, 4081/30 special turned to accommodate the small return pipes for injection nozzles on diesel engines; 12-pt., Chrome-Vanadium-Steel 31 CrV 3 (1.2208), matt chrome finish

Für / For:
VW / AUDI, MERCEDES BENZ, FORD, OPEL,
VOLVO, PEUGEOT, DAIHATSU, MAZDA, TOYOTA





Art.-Nr. / No.	mm	mm	g	VE	EUR
4081 00 21	27	80	240	5	18,10
4081 00 30	27	80	300	5	20,10

Art.-Nr. / No.	 mm	 mm	 g	 VE	EUR	4081/39/65
4081 00 39	22	110	180	1	34,40	<p>Für Einspritzdüsen an Dieselmotoren, mit Fenster, lange Ausführung, 6-kant, Chrom-Vanadium-Stahl 31 CrV 3</p> <p>For injection nozzles on diesel engines, with window, long type, 6-pt., Chrome-Vanadium-Steel 31 CrV 3 (1.2208)</p> <p>Für / For: MERCEDES BENZ (C/E, 604, 605, 606) etc.</p> <p>MERCEDES BENZ (C/E, 602-06, 611) , VW/AUDI/ SKODA/SEAT, BMW, FORD, OPEL, ROVER, VOLVO etc.</p>
4081 00 65	22	110	200	1	49,00	

Einsätze für Einspritzdüsen

Sockets for injection nozzles





Art.-Nr. / No.	 mm	 mm	 g	 VE	EUR	4081/60
4081 00 60	27	80	375	1	49,00	<p>Mit Aussparungen (35x35mm) zum Aus- und Eindrehen von Diesel-Einspritzdüsen ohne Beschädigung der Rücklauf-Röhrchen. 12-kant, Spezialstahl, brüniert</p> <p>With notch (35x35mm) for screwing of diesel injection nozzles without damaging the return pipe, 12-pt., special steel, black phosphated</p> <p>Für / For: VW/AUDI/SEAT/SKODA, BMW, FORD, DB ACTROS</p>

Einsatz für Einspritzdüsen

Socket for injection nozzles







Art.-Nr. / No.	 mm	 g	 VE	EUR	7053/1
7053 00 01	60	155	1	32,00	<p>Für Druckmutter an Düsenhaltern von Diesel-Einspritzdüsen mit Nadelbewegungsfühler, mit vier Zapfen, extra tief, Innen-Bohrung zum Durchschieben Nadelbewegungsfühler; Spezialstahl, brüniert</p> <p>For nozzle holder nut in diesel engines, with four taps, extra deep; with inside bore for exhaust system; special steel, black phosphated</p> <p>Für / For: EURO II / III, MAN (~80.99603-0121), MERCEDES BENZ (~403 589 04 07 00)</p>

Zapfenschlüssel für Einspritzdüsen

Crown Socket for injection nozzles



Art.-Nr. / No.	 mm	 mm	 g	 VE	EUR	7053/4
7053 00 04	32	120	255	1	48,00	<p>Für Druckmutter an Düsenhaltern von Diesel-Einspritzdüsen mit Nadelbewegungsfühler, mit vier Zapfen, extra tief, Innen-Bohrung zum Durchschieben Nadelbewegungsfühler; Spezialstahl, brüniert</p> <p>For nozzle holder nut in diesel engines, with four taps, extra deep; with inside bore for exhaust system; special steel, black phosphated</p> <p>Für / For: EURO II / III, MAN (~80.99603-0240), MERCEDES BENZ (~442 589 00 07 00)</p>

Zapfenschlüssel für Einspritzdüsen

Crown Socket for injection nozzles

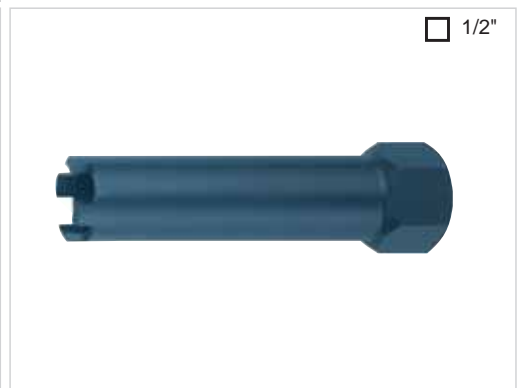

Klemmutter-Schlüssel Clamp Nut Wrenches

- 1/2"
- 3/4"



4089

Art.-Nr. / No.

mm

g VE

EUR

Zum Lösen und Festziehen der Klemmmuttern an den Achsen, Spezialstahl, brüniert

For clamp nuts on front axles, special steel, black phosphated

Für / For:

MERCEDES BENZ (VL 2/7-8, Typen/Types 1013 S-K, 1017 S-K, z.B./e.g. Atego, Nr. 675 330 00 88)

MERCEDES BENZ (VL 2/11, Typ 814, neue Leichtbaureihe/new light models)

DAF, MERCEDES BENZ (VL 3/8, 4/7, 4/9, 4/15, VD 4/14, Typen/Types 363, 385, 387, 839, 391, 393, 395, 617, 620-23, 625, 649, z.B. / e.g. Nr. 652 330 00 88); MAN (81.92901-0066); KÄSSBOHRER / SETRA (Vorderachse/front axle 6,5 / 7,5t in S 210, S215, SG 219-221, S 216 HDS, S 288 DT)

MERCEDES BENZ (Vorderachse/front axle VL 5/1 D-9, VL 5/2-D-9, Typen/Types 2629/6x4, 2635 K/6x4, 3535 K/8x4/4, z.B./e.g. Atego, Nr. 656 330 00 88)

1/2"

4089 00 01

41x50

500

1

65,00

4089 00 03

50x62

520

1

65,00

3/4"

4089 00 05

56x71

770

1

68,00

4089 00 06

60x76

850

1

72,00

Krähen-Fuß-Schlüssel Open Box Wrenches

- 1/2"



4094

Art.-Nr. / No.

mm

mm

mm

VE

EUR

Schlüsselköpfe "Tropfenform", besonders geeignet für sehr hohe Drehmomente beim Lösen festsitzender Schraubverbindungen; Anwendungsbereiche: z.B. Bagger, Kräne, Baufahrzeuge sowie bei Klimaanlagen von MAN und MB-LKW; aus speziellem Chrom-Molybdän-Stahl, 12-kant, brüniert

Open Box Wrenches, high torque to loose tight screws; further applications are e.g. excavators, cranes, construction vehicles as well as e.g. for air conditions on MAN and MB-trucks; special chrome-molybdenum-steel, 12-pt., black phosphated

4094 00 01

17

60

32x20

1

55,00

4094 00 02

18

63

35x20

1

58,00

4094 00 03

19

63

35x20

1

58,00

4094 00 04

22

65

40x25

1

58,00

4094 00 05

24

70

45x25

1

65,00

4094 00 06

27

75

48x25

1

65,00

Achsmuttern-Schlüssel Axle Nut / Wheel Cap Wrenches

- 3/4"



5080/5081

Art.-Nr. / No.

mm

g VE

EUR

Zum Lösen und Festziehen von Radkapseln, mit flach-ovalem Profil für BPW (65mm) und ECO-Achsen; Spezialstahl, brüniert

For mounting and dismounting of wheel caps, with flat-oval profile; for BPW (65mm) and ECO-axles; special steel, black phosphated

5080 00 01

65

1200

1

138,00

5080 00 02

80

1300

1

158,00

5080 00 03

85

1500

1

158,00

5081 00 01

95

1600

1

125,00

5081 00 02

110

1800

1

145,00

5081 00 03

120

1950

1

148,00

Für / For:

BPW / ECO-Achsen / Axes

Art.-Nr. / No. a \varnothing b \longleftrightarrow  
 mm mm mm g VE

5084

Klauen-/Zapfenschlüssel
 Claw Wrenches

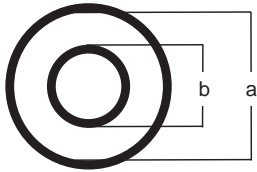



a: Innendurchmesser Grundkörper
 Inside diameter of basic body
 b: Außendurchmesser Führungsrohr
 Outside diameter of guide

Zum Lösen und Festdrehen der Befestigungsmuttern an der Vorder- und Hinterachse sowie am Getriebe- und Differentialflansch, bestehend aus Grundkörper und Führungsrohren, Führungsrohre auswechselbar, mit 6 Zapfen; hohe Zeit- und Kostenersparnis, Spezialstahl, brüniert

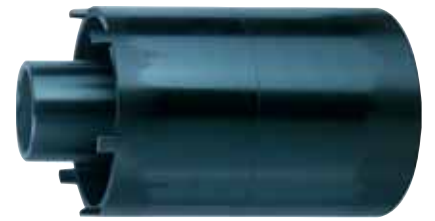
For mounting and dismounting of the locking nuts at front and rear axles and differential gear, consists of basic body and guides, guides exchangeable, with 6 pins; special steel, black phosphated





Art.-Nr. / No.	a \varnothing mm	b mm	\longleftrightarrow mm	 g	 VE	EUR
5084 00 01	63,0		75	2400	1	320,00
		36,0	125			
		40,5	125			
		42,0	80			
		43,0	125			

1 Grundkörper mit 6 Zapfen (Breite 7,5mm), 4 Führungsrohre

1 Basic body with 6 pins (width 7,5mm), 4 guides

Für / For:
 MERCEDES BENZ (Actros Hypoid-Hinterachse / Hypoid rear axle HL2/2, HL2/3, HL2/5, HL2/9, HL2/11, HL2/15) etc.





Art.-Nr. / No.	a \varnothing mm	b mm	\longleftrightarrow mm	 g	 VE	EUR
5084 00 02	77,0		70	1800	1	175,00
		49,0	100			

1 Grundkörper mit 6 Zapfen (Breite 10mm), 1 Führungsrohr

1 Basic body with 6 pins (width 10mm), 1 guide

Für / For:
 MAN (Hypoid-/Banjo-Hinterachse G-Reihe / Hypoid rear axle G-types VW 2, VW 4, VW 6.1-6.8; L 2000) etc.





Art.-Nr. / No.	a \varnothing mm	b mm	\longleftrightarrow mm	 g	 VE	EUR
5084 00 03	87,0		65	3200	1	265,00
		49,0	150			
		57,0	140			

1 Grundkörper mit 6 Zapfen (Breite 10mm), 2 Führungsrohre

1 Basic body with 6 pins (width 10mm), 2 guides

Für / For:
 MAN, MERCEDES BENZ (Atego HL 2, 814 Vitaro) etc.





Art.-Nr. / No.	a \varnothing mm	b mm	\longleftrightarrow mm	 g	 VE	EUR
5084 00 04	102,0		140	4600	1	289,00
		51,5	135			
		66,5	135			

1 Grundkörper mit 6 Zapfen (Breite 11,4mm), 2 Führungsrohre

1 Basic body with 6 pins (width 11,4mm), 2 guides

Für / For:
 MAN (Außenplaneten-Hinterachse F-Reihe / Outside planetary rear axes F-Row H7, HD7; Vorderachsen F-Reihe VA), Hypoid-Hinterachsen F-Reihe / Hypoid rear axle F-Row HY-1175, HDY-1175, HY-13110, HY-1180) etc.



Art.-Nr. / No.	a \varnothing mm	b mm	\longleftrightarrow mm	 g	 VE	EUR
5084 00 05	117,0		180	6800	1	258,00
		60,0	195			

1 Grundkörper mit 6 Zapfen (Breite 9,8mm), 1 Führungsrohr

1 Basic body with 6 pins (width 9,8mm), 1 guide

Für / For:
 MERCEDES BENZ (Actros Hypoid-Hinterachse / Hypoid rear axle HL/HL8) etc.



Kerzbahn-Einsatz für Vorkammern
Crown socket for pre-chambers

7053/6

Art.-Nr. / No.

mm g VE EUR

1/2"



Für Vorkammer-Mutter neuerer MB-Dieselmotoren, z.B. 601, 602, 603 ab Baujahr 1989; Spezialstahl, brüniert

Grooved Socket for pre-chambers with special outside grooves for pre-chamber nuts of; special steel, black phosphated

Für / For:
MERCEDES BENZ (601-03; ~604 589 01 09 00)

7053 00 06 60 215 1 37,50

Spezial-Rohrsteckschlüssel
Special Tubular Box Spanner

938/20

Art.-Nr. / No.

mm mm g VE EUR



Extra langer Rohrsteckschlüssel, z.B. für BPW-Achsen, Spezialstahl, brüniert

Extra long tubular box spanner, e.g. for BPW-axes, special steel, black phosphated

Für / For:
MERCEDES BENZ, MAN (BPW-Achsen / Axes etc.)

0938 00 20 30x32 450 415 1 37,50



Weitere
Spezialwerkzeuge?

Fragen Sie uns.
Als Partner der
Automobilindustrie
haben wir das richtige
Know-How und verfügen
über modernste
Fertigungskapazitäten, um
auch Ihre Anforderungen
zu erfüllen.

More special tools?

Just ask us - as a partner of
the leading OEM we really
know how to do it - with the
help of the latest
manufacturing technology.

Art.-Nr. / No. a \varnothing b \longleftrightarrow  
 mm mm mm g VE

5084

Klauen-/Zapfenschlüssel
 Claw Wrenches

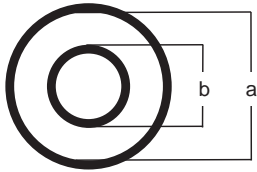



a: Innendurchmesser Grundkörper
 Inside diameter of basic body
 b: Außendurchmesser Führungsrohr
 Outside diameter of guide

Zum Lösen und Festdrehen der Befestigungsmuttern an der Vorder- und Hinterachse sowie am Getriebe- und Differentialflansch, bestehend aus Grundkörper und Führungsrohren, Führungsrohre auswechselbar, mit 6 Zapfen; hohe Zeit- und Kostenersparnis, Spezialstahl, brüniert

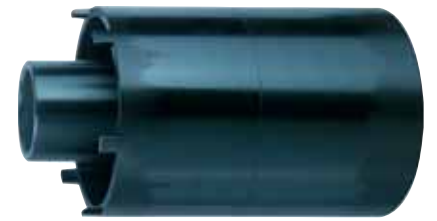
For mounting and dismounting of the locking nuts at front and rear axles and differential gear, consists of basic body and guides, guides exchangeable, with 6 pins; special steel, black phosphated





Art.-Nr. / No.	a \varnothing mm	b mm	\longleftrightarrow mm	 g	 VE	EUR
5084 00 01	63,0		75	2400	1	320,00
		36,0	125			
		40,5	125			
		42,0	80			
		43,0	125			

1 Grundkörper mit 6 Zapfen (Breite 7,5mm), 4 Führungsrohre

1 Basic body with 6 pins (width 7,5mm), 4 guides

Für / For:
 MERCEDES BENZ (Actros Hypoid-Hinterachse / Hypoid rear axle HL2/2, HL2/3, HL2/5, HL2/9, HL2/11, HL2/15) etc.





Art.-Nr. / No.	a \varnothing mm	b mm	\longleftrightarrow mm	 g	 VE	EUR
5084 00 02	77,0		70	1800	1	175,00
		49,0	100			

1 Grundkörper mit 6 Zapfen (Breite 10mm), 1 Führungsrohr

1 Basic body with 6 pins (width 10mm), 1 guide

Für / For:
 MAN (Hypoid-/Banjo-Hinterachse G-Reihe / Hypoid rear axle G-types VW 2, VW 4, VW 6.1-6.8; L 2000) etc.





Art.-Nr. / No.	a \varnothing mm	b mm	\longleftrightarrow mm	 g	 VE	EUR
5084 00 03	87,0		65	3200	1	265,00
		49,0	150			
		57,0	140			

1 Grundkörper mit 6 Zapfen (Breite 10mm), 2 Führungsrohre

1 Basic body with 6 pins (width 10mm), 2 guides

Für / For:
 MAN, MERCEDES BENZ (Atego HL 2, 814 Vitaro) etc.





Art.-Nr. / No.	a \varnothing mm	b mm	\longleftrightarrow mm	 g	 VE	EUR
5084 00 04	102,0		140	4600	1	289,00
		51,5	135			
		66,5	135			

1 Grundkörper mit 6 Zapfen (Breite 11,4mm), 2 Führungsrohre

1 Basic body with 6 pins (width 11,4mm), 2 guides

Für / For:
 MAN (Außenplaneten-Hinterachse F-Reihe / Outside planetary rear axes F-Row H7, HD7; Vorderachsen F-Reihe VA), Hypoid-Hinterachsen F-Reihe / Hypoid rear axle F-Row HY-1175, HDY-1175, HY-13110, HY-1180) etc.



Art.-Nr. / No.	a \varnothing mm	b mm	\longleftrightarrow mm	 g	 VE	EUR
5084 00 05	117,0		180	6800	1	258,00
		60,0	195			

1 Grundkörper mit 6 Zapfen (Breite 9,8mm), 1 Führungsrohr

1 Basic body with 6 pins (width 9,8mm), 1 guide

Für / For:
 MERCEDES BENZ (Actros Hypoid-Hinterachse / Hypoid rear axle HL/HL8) etc.



Kerzbahn-Einsatz für Vorkammern
Crown socket for pre-chambers

7053/6

Art.-Nr. / No.

mm g VE EUR

1/2"



Für Vorkammer-Mutter neuerer MB-Dieselmotoren, z.B. 601, 602, 603 ab Baujahr 1989; Spezialstahl, brüniert

Grooved Socket for pre-chambers with special outside grooves for pre-chamber nuts of; special steel, black phosphated

Für / For:
MERCEDES BENZ (601-03; ~604 589 01 09 00)

7053 00 06 60 215 1 37,50

Spezial-Rohrsteckschlüssel
Special Tubular Box Spanner

938/20

Art.-Nr. / No.

mm mm g VE EUR



Extra langer Rohrsteckschlüssel, z.B. für BPW-Achsen, Spezialstahl, brüniert

Extra long tubular box spanner, e.g. for BPW-axes, special steel, black phosphated

Für / For:
MERCEDES BENZ, MAN (BPW-Achsen / Axes etc.)

0938 00 20 30x32 450 415 1 37,50



Weitere
Spezialwerkzeuge?

Fragen Sie uns.
Als Partner der
Automobilindustrie
haben wir das richtige
Know-How und verfügen
über modernste
Fertigungskapazitäten, um
auch Ihre Anforderungen
zu erfüllen.

More special tools?

Just ask us - as a partner of
the leading OEM we really
know how to do it - with the
help of the latest
manufacturing technology.

Inhalt Index



Sortimente
Assortments

Sortimente / Assortments

Werkzeugkoffer Hard shell case with tools

8153

Art.-Nr. / No.

kg VE EUR

8153 00 20	leer / empty	5	1	135,00
8153 00 50	38-tlg. / pcs.	8,5	1	310,00



- MATADOR-Hartschalenkoffer aus ABS-Kunststoff:
- Stoßkantenprofil als Abdeckung und Designelement
 - Aluminiumrahmen, gehärtet und verwindungssteif
 - Deckelhalter zweifach vernietet
 - Kleinteilefach mit Kunststoffeinteilungen
 - Schlösser, original Sudhaus-Schlösser
 - Ergonomisch geformt, rutschsicher und höchster Tragekomfort
 - 2 Werkzeugtafeln, eine austauschbar, öl- und wasserabweisend
 - Maße: 460 x 160 x 310mm

- MATADOR-hard shell case, made of ABS material:
- Designed edgeprofile
 - Aluminium frame, hardened, torsion resistant
 - Double-riveted cover
 - Box for small parts with plastic divisions
 - Original Sudhaus Locks
 - Handle; ergonomically designed, non sliding
 - Two tools panels, one exchangeable, oil and water resistant
 - Measurements: 460 x 160 x 310mm



Inhalt / contents:

	185	8; 10; 11; 13; 14; 17; 19; 22mm
	444L	1,5 -10mm
	500	180 mm
	532	160mm
	556	240mm
	615	5 x 100; 5,5 x 125; 6,5 x 150mm
	655	PH 1; 2
	635	
	705	400g
	714	200mm
	717	120 x 4mm
	718	3; 4; 5; 6mm
	775	200mm
	787	250mm
	798	5m
	799	140mm
	826	

Zubehör für Werkzeugkoffer Accessories for hard shell case

8153/1

Art.-Nr. / No.

g VE EUR

8153 01 11	520	1	24,95
8153 01 12	480	1	24,95



Werkzeugtafel mit 33 Einsteckfächern
Tool panel with 33 inserted partitions



Werkzeugtafel mit 48 Gummibandschlaufen
Tool panel with 48 rubber loops

Art.-Nr. / No.	mm	kg	VE	EUR	
8153 00 80	430x180x260	2,8	1	79,00	8153/80

Klassische Werkzeugtasche aus Rindsleder zum Umhängen oder Tragen; mit umlaufendem Alu-Kantenschutz und aufklappbarer Vorderwand

Classical leather bag made of neat's leather for carrying or to be used as shoulder-bag; with aluminium edge protection and foldable front side



“Azubi”-Werkzeugtasche, leer
Leather Bag, empty



Art.-Nr. / No.		kg	VE	EUR	
8153 00 81	MM	15	1	249,00	8153/81
8153 01 81	AF	15	1	249,00	

Klassische Werkzeugtasche aus Rindsleder zum Umhängen oder Tragen; mit Basis-Werkzeugsatz

Classical leather bag made of neat's leather for carrying or to be used as shoulder-bag; with basic tools assortment

“Azubi”-Werkzeugtasche, 38-tlg.
Leather Bag with tool set, 38 pcs



	185	8; 10; 11; 13; 14; 17; 19; 22mm		705	400g
	444L	1,5 -10mm		714	200mm
	500	180mm		717	120 x 4mm
	532	160mm		718	3; 4; 5; 6mm
	556	240mm		775	200mm
	615	5 x 100; 5,5 x 125; 6,5 x 150mm		787	250mm
	655	PH 1; 2		798	5m
	635			799	140mm
				826	

Art.-Nr. / No.		g	VE	EUR	
8160 00 01	16-tlg. / pcs.	1800	1	85,00	8160

Satz mit den wichtigsten Werkzeugen für kleine Reparaturen, in Kunststoffkoffer

Set with the most important tools, in plastic case

Haushaltssatz Werkzeuge
Set of tools for household



	185	8; 10; 11; 13; 14; 17; 19; 22mm		705	400g
	615	5 x 100; 5,5 x 125; 6,5 x 150mm, PH1+2		798	5m
	500	180mm		635	

Profi-Werkzeugtrolley "Caddy"
Professional Tools Trolley "Caddy"

8153

Art.-Nr. / No. kg VE EUR



Doppelwandiger Werkzeugkoffer aus HDPE-Kunststoff, durch "blow molded-Verfahren" robust gegen Hitze- und Kälteeinflüsse sowie mechanische Belastung und resistent gegen chemische Einflüsse.

Ideal für Luftfahrtingenieure, Service-Techniker und mobile Anwender.

Bequemer Transport auf Rollen, Teleskopgriff, stapelfähig.

Ausstattung:

- Doppelwandkonstruktion
- 2 Werkzeugpaletten mit Einstecktaschen, eine Palette einseitig, die andere beidseitig bestückbar
- 1 Dokumentenfach
- 2 Kleinteileboxen
- Softgriff mit Rückhaltefeder
- 2 Deckelhalterungen aus Metall (Gurtösen)
- 2 abschließbare Schlösser
- Bodenraum mit variabler Einstellmöglichkeit
- Robuste Stahlscharniere, fest vernietet, mit 2 zusätzlichen innenliegenden Deckelscharnieren
- 4 GummifüÙe auf der Kofferunterseite
- Einrastender Teleskopgriff
- Große leichtgängige Transportrollen
- Tragfähigkeit: ca. 35kg
- Maße: 453 x 185 x 345mm (L x B x H)

Double-walled (blow moulded) tool trolley, made of HDPE-plastic, sturdy against heat, coldness and mechanical load, resistant to chemicals.

Ideal for aviation engineers, service technicians and mobile users.

Comfortable transport by wheels and retractable handle, stapleable.

Features:

- Double wall construction
- 2 tool panels with pouches, one panel equipable on one side, the other on both sides
- 1 document wallet
- 2 boxes for small parts
- Soft-rubber-grip-handle
- 2 metal holders for the top cover
- Bottom tray with adjustable compartments
- Solid steel hinges riveted to bottom and top cover with 2 additional internal hinges for the top cover
- 4 rubber feet on the outside bottom part
- Retractable handle
- Large, smooth-running wheels
- Loading capacity: max. 35 kg
- Size: 453 x 185 x 345mm (L x W x H)



+ Profi-Bitbox, 31-tlg.
+ Professional Bitbox, 31-pcs.

8153 60 30 121-tlg. / pcs. 15 1 **798,00**

Koffer, leer / empty case
8153 00 30 7,5 1 **245,00**

Inhalt / contents:

	186	8; 9; 10; 12-15; 17; 18; 19mm
	500	180 mm
	532	200mm
	556	240mm
	615	5 x 100; 6,5 x 150mm
	640 655	6,5 x 25mm PH 2
	655	PH 1; 2
	705	400g
	714	125mm
	716	3mm
	843	
	2061	
	2064 2065 2066	115mm 50, 100mm
	2075	4-13mm
	2080	8, 10, 12, 13mm
	2083 2084 3083	1/4 - 3/8 1/4 - 1/4 Bits 1/2 - 3/8
	2090	E 4-8, E 10, E 11
	2092	TX 8, 10, 15, 20, 25, 27, 30, 40
	4061	
	4065 4066	125mm 250mm
	4075	10-22mm
	4079	B&S XZN M6, M8, M10, M12
	4092	TX 45, 50, 55

Art.-Nr. / No.	mm	kg	VE	EUR	8170/8175
8170 00 20	420x150x200	3,3	1	32,50	Aufziehbar, blau lackiert, abschließbar mit Vorhängeschloss, 3- oder 5-teilig, aus Stahlblech, ohne Inhalt Tool Boxes with 3 or 5 trays, blue lacquered; can be locked with padlock; heavy gauge sheet steel, without tools
8175 00 20	530x200x200	5,2	1	48,00	

Werkzeug-Tragekasten, leer

Tool Boxes, empty







Art.-Nr. / No.	MM	kg	VE	EUR	8171
8170 00 01	MM	16,5	1	450,00	Werkzeugsortiment im 3-teiligen Tragekasten Tool Assortment in Tool Box with 3 trays
8170 01 01	AF	15,5	1	460,00	

Werkzeugsortiment, 85-/86-tlg.

Tool Assortment, 85/84 pcs



Inhalt / contents:

 100 6-22mm	 578-584 A2, A21, J2, J21	 700 35mm	 782
 200 6-22mm	 596 1.1/2"	 705 400g	 787
 440 1,5-10mm	 615 5x100; 6,5x150mm	 719/2	 840
 500 180mm	 655 PH1, PH2	 745 250mm	 846
 530 180mm	 660 3x100mm	 760 13x0,05-1,00	 4061 4064 4065/66/68
 556 240mm	 776 250mm	 4075 10-22mm	





Art.-Nr. / No.	MM	kg	VE	EUR	8176
8176 00 01	MM	25,5	1	675,00	Werkzeugsortiment im 5-teiligen Tragekasten Tool Assortment in Tool Box with 5 trays
8176 01 01	AF	23,5	1	595,00	

Werkzeugsortiment, 108-/104-tlg.

Tool Assortment, 108/104 pcs



Inhalt / contents:

 100 6-32mm	 615 5; 6,5; 8; 10mm	 752 500mm	 814
 200 6-32mm	 633	 760 13x0,05-1,00	 825
 440 1,5-10mm	 655 PH1, PH2, PH3	 778 5-tlg./pcs.	 840 842
 500 180mm	 660 3x100mm	 780	 846
 530 180mm	 700 35mm	 781	 860
 556 240mm	 705 400g	 782 852	 4061 4064 4065/66/68
 425 240mm	 718 3, 4, 5mm	 783	 4075 10-22mm
 596 1.1/2"	 719/2	 786	 4081 16; 20,8mm

Individuelle Zusammenstellungen auf Anfrage.
Please ask for individual assortments.

Metrische Maße / Metric Sizes											
Schlüsselweite / openings mm	Gewinde-Durchmesser / Thread Diameter										
	ISO R 272 1968		Deutsche Norm DIN metrisch			Norwegische Norm	Französische Norm	Schwedische Norm			
	normaler Sechskant	kleiner Sechskant	normaler Sechskant	kleiner Sechskant	großer Sechskant			metrisch	Whitworth		
						klein 1414	groß 1412	klein 1415	groß 1413		
2,5			1								
3			1,2 + 1,4								
3,2	1,6		1,6								
3,5			1,7								
4	2		2		1,7	2,5	2,3				
4,5			2,3		2		2,6				
5	2,5		2,5 + 2,6		2,3	3	3				
5,5	3		3		2,6						
6			3,5		3	3,5	3,5	3			
7	4		4		3,5	4 + 4,5	4	3,5			
8	5		5	6	4	5	5	4			
9					5	5,5	5				
10	6		6	8		6	6				
11	7		7		6 + 7		7	6			
12	8					7	8				
13	8		8	10					5/16	1/4	
14	10				8	8		8			
15			(10)+				10		3/8	5/16	
16						9					
17	10	12	10	12	9 + 10	10		10			
18							12		7/16	3/8	
19	12	14	12	16	11	11					
20											
20,8	Zündkerzen M 14										
21						12	14		1/2	7/16	
22	14	16	14		12	12 + 14		12 + 14			
23							14			1/2	
24	16	18	16	20			16		5/8		
25											
26	Zündkerzen M 18										
27	18	20	18		16	16		18	16		
28									3/4	5/8	
29							18				
30	20	22	20	24			20				
32	22	24	22		20	18 + 20	20	22	18 + 20		
33									7/8	3/4	
34							24				

Amerikanische Maße / American Sizes						
Schlüsselweite Openings	Gewinde-Durchmesser Thread Diameter					
	AF	mm	Schrauben und Muttern nach SAE	USS		Americ. Standard
				Schrauben und Muttern	Kopfschrauben	
			Schrauben und Muttern	Schrauben und Muttern	Schrauben und Muttern	Kopfschrauben
1/8	3,175					
5/32	3,97				0 + 1	
3/16	4,76				2 + 3	
13/64	5,16					
7/32	5,56					
15/64	5,95					
1/4	6,35				4	
17/64	6,75					
9/32	7,14					
19/64	7,54					
5/16	7,94		1/8	1/8	5 + 6	
11/32	8,73				8	
3/8	9,52			3/16	10	
13/32	10,32					
7/16	11,11	1/4		1/4	12 + 1/4	1/4
15/32	11,90					
1/2	12,70	5/16	1/4	5/16		5/16
9/16	14,29	3/8		3/8	5/16	3/8
19/32	15,08		5/16			
5/8	15,88	7/16		7/16	3/8	7/16
11/16	17,46		3/8			
3/4	19,05	1/2		1/2	7/16	1/2
25/32	19,84		7/16			
13/16	20,64			9/16	1/2	9/16
7/8	22,22	9/16	1/2	5/8	9/16	5/8
15/16	23,81	5/8				
31/32	24,61		9/16			
1	25,40	11/16		3/4	5/8	3/4
1.1/16	26,99	3/4	5/8			
1.1/8	28,57			7/8	3/4	7/8
1.3/16	30,16					
1.1/4	31,75	7/8	3/4	1		
1.5/16	33,34				7/8	1

Englische Maße English Sizes					
Bolzenstärke Bolt Diameter			Schlüsselweite Openings		
BSW großer Sechskant BS 192	BSF und BSW kleiner Sechskant BS 1083	BA	Zoll	mm	
			inch decimal		
			10	.117	2,97
			9	.131	3,33
			8	.152	3,86
			7	.172	4,37
			6	.193	4,90
			5	.220	5,59
			4	.248	6,30
1/16 =	3/32			.256	6,50
			3	.282	7,16
3/32 =	1/8			.297	7,54
			2	.324	8,23
1/8 =	3/16			.340	8,64
			1	.365	9,27
			0	.412	10,49
3/16 =	1/4			.445	11,30
1/4 =	5/16			.525	13,33
5/16 =	3/8			.600	15,24
3/8 =	7/16			.710	18,03
7/16 =	1/2			.820	20,83
1/2 =	9/16			.920	23,34
9/16 =	5/8			1.010	25,65
5/8 =	11/16			1.100	27,94
11/16 =				1.200	30,48
3/4 =	7/8			1.300	33,02

Metrische Maße / Metric Sizes											
mm	Gewinde-Durchmesser / Thread Diameter										
	ISO R 272 1968		Deutsche Norm DIN metrisch			Norwegische Norm	Französische Norm	Schwedische Norm			
	normaler Sechskant	kleiner Sechskant	normaler Sechskant	kleiner Sechskant	großer Sechskant			metrisch	Whitworth		
						klein 1414	groß 1412	klein 1415	groß 1413		
35						22					
36	24	27	24	30	22	22 + 24		22 + 24			
37									1	7/8	
38							24				
41	27	30	27		24	27		27			
42			M26x1,5				27		1.1/8	1	
46	30	33	30	36	27	30	30	30			
47									1.1/4	1.1/8	
50	33	36	33			33	33	33			
52									1.3/8	1.1/4	
54							36				
55	36	39	36	42		36		36			
56									1.1/2	1.3/8	
58							39				
60	39		39			39		39	1.5/8	1.1/2	
63							42				
65	42		42	48		42		42	1.3/4	1.5/8	
67							45				
70	45		45			45		45	1.7/8	1.3/4	
71							48				
75	48		48	56		48		48	2	1.7/8	
77							52				
80	52		52			52		52		2	
82							56				
85	56		56			56		56		2.1/4	
88							60				
90	60		60			60		60			
94							64				
95	64		64			64		64		2.1/2	
100	68		68			68	68	68			
105	72		72			72	72	72		2.3/4	
110	76		76			76	76	76		3	
115	80		80			80		80			
116							80				
120	85		85			84		85		3.1/4	
130	90		90			89		90		3.1/2	
135	95		95			94		95		3.3/4	
145	100		100			99		100		4	
150	105		105			104		105			
155	110		110			109		110		4.1/4	

Amerikanische Maße / American Sizes						
Schlüsselweite Openings	Gewinde-Durchmesser Thread Diameter					
	AF	mm	Schrauben und Muttern nach SAE		Americ. Standard	Kopfschrauben
			Schrauben und Muttern	Kopfschrauben		
			Schrauben und Muttern	Kopfschrauben	Schrauben und Muttern	Kopfschrauben
1.3/8	34,92			1.1/8		
1.7/16	36,51	1	7/8			
1.1/2	38,10			1.1/4	1	1.1/8
1.9/16	39,69					
1.5/8	41,28	1.1/8	1	1.3/8		
1.11/16	42,86				1.1/8	1.1/4
1.3/4	44,45					
1.13/16	46,04	1.1/4	1.1/8			
1.7/8	47,63		1.1/4			
2	50,80	1.3/8	1.1/4			
2.1/16	52,39				1.3/8	
2.3/16	55,56	1.1/2	1.3/8			
2.1/4	57,15				1.1/2	
2.3/8	60,32		1.1/2			
2.7/16	61,91				1.5/8	
2.9/16	65,09		1.5/8			
2.5/8	66,68				1.3/4	
2.3/4	69,85		1.3/4			
2.13/16	71,44				1.7/8	
2.15/16	74,61		1.7/8			
3	76,20				2	
3.1/8	79,38		2			
3.3/8	85,72				2.1/4	
3.1/2	88,90		2.1/4			
3.3/4	95,25				2.1/2	
3.7/8	98,42		2.1/2			
4.1/8	104,78				2.3/4	
4.1/4	107,95		2.3/4			
4.1/2	114,30				3	
4.5/8	117,48		3			
5	127,00		3.1/4			
5.3/8	136,52		3.1/2			
5.3/4	146,05		3.3/4			
6.1/8	155,57		4			

Englische Maße English Sizes					
Bolzenstärke Bolt Diameter			Schlüsselweite Openings		
BSW großer Sechskant BS 192	BSF und BSW kleiner Sechskant BS 1083	W	BA	Zoll	mm
				inch decimal	
13/16 =	15/16			1.390	35,31
7/8 =	1			1.480	37,59
15/16 =	1.1/16			1.580	40,13
1 =	1.1/8			1.580	42,42
1.1/8 =	1.1/4			1.860	47,24
1.1/4 =	1.3/8			2.050	52,07
1.3/8 =	1.1/2			2.220	56,39
1.1/2 =	1.5/8			2.410	61,21
1.5/8 =	1.3/4			2.580	65,53
1.3/4 =	2			2.760	70,10
2 =	2.1/4			3.150	80,01
2.1/4 =	2.1/2			3.550	90,17
2.1/2 =	2.3/4			3.890	98,81
2.3/4 =	3			4.180	106,17
3 =	3.1/4			4.530	115,06
3.1/4 =	3.1/2			4.850	123,19
3.1/2 =	3.3/4			5.180	131,57
3.3/4 =	4			5.550	140,92



Vergleichstabelle von Schlitzschrauben mit Anwendungsempfehlungen für MATADOR - Schraubendreher-Einsätze und -Bits









Schrauben mit metrischem Gewinde						Holzschrauben Ø mm			Blechschraben Ø mm			Schneiden- maße	MATADOR - Schraubendreher-Einsätze, Bits								
A Zylinderschrauben B Flachkopfschrauben C Gewindestifte		D Senkschrauben E Linsensenschrauben		F Linsensenschrauben G Halbrundschraben H Senkschrauben			I Zylinderschrauben J Senkschrauben K Linsensenschrauben						2076	3076	4076	7020	7030				
A	B	C		D	E	F	G	H	I	J	K										
DIN 84 7513	DIN 85	DIN 417, 427 438, 551 553, 926		DIN 927	DIN 963 7513	DIN 964 7513	DIN 95	DIN 96	DIN 97	DIN 7971	DIN 7972	DIN 7973									
M2				M3	M2	M2	2	2	2				0,5 x 3								
M2,5				M4	M2,5	M2,5	2,5	2,5	2,5	2,2		2,2	0,6 x 4								
M2,5				M4				2,5					0,6 x 4,5								
													0,7 x 4	•							
M3	M3			M5	M3	M3	3	3	3	2,9		2,9	0,8 x 5							•	
M3 / M3,5	M3 / M3,5			M5	M3,5	M3,5	3,5	3,5	3,5	2,9			0,8 x 5,5	•						•	•
M4				M6	M4	M4	4		4	3,5		3,5	1 x 6							•	
M4	M4			M6			4,5	4 / 4,5	4,5	3,9		3,9	1 x 7	•	•					•	•
M5	M5			M6	M5	M5	5 / 5,5	5 / 5,5	5	4,2 / 4,8		4,2 / 4,8	1,2 x 8		•	•				•	•
M6				M6	M6	M6	6	6	6	5,5		5,5 / 6,3	1,6 x 9		•					•	•
	M6									6,3		6,3	1,6 x 11								
M8				M8	M8	M8	8	7	8				2 x 12							•	•
	M8							7					2 x 14							•	
M10				M10	M10	M10							2,5 x 14								
M10					M10	M10							2,5 x 16								



Vergleichstabelle von Schlitzschrauben mit Anwendungsempfehlungen für MATADOR - Schraubendreher









Schrauben mit metrischem Gewinde						Holzschrauben Ø mm			Blechschraben Ø mm			Schneiden- maße	MATADOR - Schraubendreher										
A Zylinderschrauben B Flachkopfschrauben C Gewindestifte		D Senkschrauben E Linsensenschrauben		F Linsensenschrauben G Halbrundschraben H Senkschrauben			I Zylinderschrauben J Senkschrauben K Linsensenschrauben						600	605	615	616	640	660	627				
A	B	C		D	E	F	G	H	I	J	K												
DIN 84 7513	DIN 85	DIN 417, 427 438, 551 553, 926		DIN 927	DIN 963 7513	DIN 964 7513	DIN 95	DIN 96	DIN 97	DIN 7971	DIN 7972	DIN 7973											
M1,6		M2,5 / M3	M2,5	M1,6	M1,6		1,6						0,4 x 2,5								•	•	
M2			M3	M2	M2		2	2	2				0,5 x 3									•	
M2			M3					2					0,5 x 3,5								•		
		M4					2,5	2,5	2,5	2,2	2,2	2,2	0,6 x 3,5	•									
M2,5			M4	M2,5	M2,5		2,5	2,5		2,2			0,6 x 4								•	•	•
M2,5			M4					2,5					0,6 x 4,5	•									
		M5		M3			3	3	3		2,9	2,9	0,8 x 4								•		
				M3	M3		3	3				2,9	0,8 x 4,5										
M3	M3		M5		M3		3,5	3 / 3,5	3,5	2,9		2,9	0,8 x 5								•	•	
M3 / M3,5	M3 / M3,5		M5	M3,5	M3,5		3,5	3,5		2,9			0,8 x 5,5	•	•						•	•	
		M6		M4	M4		4	4	4		3,5 / 3,9	3,5	1 x 5,5										
M4	M4		M6		M4		4 / 4,5	4 / 4,5	4,5	3,5 / 3,9		3,9	1 x 6,5								•	•	
		M8		M5			5	5	5		4,2	4,2	1,2 x 6,5								•		
				M5	M5		5	5	5 / 5,5	4,2 / 4,8	4,8	4,2 / 4,8	1,2 x 7	•	•	•						•	
M5	M5			M5			5,5	5 / 5,5		4,2 / 4,8		4,8	1,2 x 8	•	•	•	•					•	
M6	M6			M6	M6		6	6	6	5,5 / 6,3	6,3	6,3	1,6 x 10	•	•	•	•					•	
M8	M8			M8	M8		8	7	8				2 x 12	•	•	•							
M10				M10	M10								2,5 x 14	•									

 Vergleichstabelle von Kreuzschlitzschrauben* mit Anwendungsempfehlungen für MATADOR-Schraubendreher, -Einsätze und -Bits

Schrauben mit metrischem Gewinde			Holzschrauben Ø mm			Blechschraben Ø mm			Kreuzschlitzgröße	MATADOR - Schraubendreher-Einsätze, Bits, MATADOR - Schraubendreher									
A Senkschrauben	B Linsensensschrauben	C Linsenschrauben	D Linsensensschrauben	E Halbrundschraben	F Senkschrauben	G Linsenschrauben	H Senkschrauben	I Linsensensschrauben		PH	628	650	655 655 / 1	656	2077	3077	4077	7024	7034
																			
DIN 965	DIN 966	DIN 7985	DIN 7995	DIN 7996	DIN 7997	DIN 7981	DIN 7982	DIN 7983											
M1,6	M1,6	M1,6	2	2	2				0			•	•						
M2	M2	M2	2,5	2,5	2,5	2,2	2,2	2,2	1	•	•	•	•	•	•			•	•
M2,5	M2,5	M2,5	3	3	3	2,9	2,9	2,9	(01)										
M3	M3	M3																	
M3,5	M3,5	M3,5	3,5	3,5	3,5	3,5	3,5	3,5	2	•	•	•	•	•	•	•	•	•	•
M4	M4	M4	4	4	4	3,9	3,9	3,9	(02)										
M5	M5	M5	4,5	4,5	4,5	4,2	4,2	4,2											
			5	5	5	4,8	4,8	4,8											
M6	M6	M6	5,5	5,5	5,5	5,5	5,5	5,5	3	•	•	•	•	•	•	•	•	•	•
			6	6	6	6,3	6,3	6,3											
			7	7	7														
M8	M8	M8	8	8	8				4	•	•	•		•		•	•	•	•
M10	M10	M10																	

* PHILLIPS-RECESS (Kreuzschlitz nach DIN 7962, Form H)

 Vergleichstabelle von Kreuzschlitzschrauben* mit Anwendungsempfehlungen für MATADOR-Schraubendreher, -Einsätze und -Bits

Schrauben mit metrischem Gewinde			Holzschrauben Ø mm			Blechschraben Ø mm			Kreuzschlitzgröße	MATADOR - Schraubendreher-Einsätze, Bits, MATADOR - Schraubendreher		
A Senkschrauben	B Linsensensschrauben	C Linsenschrauben	D Linsensensschrauben	E Halbrundschraben	F Senkschrauben	G Linsenschrauben	H Senkschrauben	I Linsensensschrauben		PZ	657	7028
												
DIN 965 7516	DIN 966 7516	DIN 7985 7516	DIN 7995	DIN 7996	DIN 7997	DIN 7981	DIN 7982	DIN 7983				
M1,6	M1,6	M1,6	2	2	2				0		•	
M2	M2	M2	2,5	2,5	2,5	2,2	2,2	2,2	1	•		•
M2,5	M2,5	M2,5	3	3	3	2,9	2,9	2,9	(01)			
M3	M3	M3										
M3,5	M3,5	M3,5	3,5	3,5	3,5	3,5	3,5	3,5	2	•		•
M4	M4	M4	4	4	4	3,9	3,9	3,9	(02)			
M5	M5	M5	4,5	4,5	4,5	4,2	4,2	4,2				
			5	5	5	4,8	4,8	4,8				
M6	M6	M6	5,5	5,5	5,5	5,5	5,5	5,5	3	•		•
			6	6	6	6,3	6,3	6,3				
			7	7	7							
M8	M8	M8	8	8	8				4	•		•
M10	M10	M10										

* POZIDRIV® (Kreuzschlitz nach DIN 7962, Form Z)

Vergleichstabelle von Innensechskantschrauben mit Anwendungsempfehlungen für MATADOR-Schraubendreher, -Einsätze und -Bits

Schrauben mit metrischem Gewinde						Schlüsselweite mm	MATADOR - Schraubendreher-Einsätze, Bits, MATADOR - Schraubendreher									
A	A	B	B	C	D		440	2078	3078	4078	7022	7032	440 L	441	444 L	4085
DIN 906	DIN 908	DIN 912	DIN 7984	DIN 913, 914, 915, 916	DIN 7991											
		M1,6 / M2		M3		1,5	•									
		M2,5	M3	M4	M3	2	•					•	•	•		
		M3	M4	M5	M4	2,5	•					•				
		M4	M5	M6	M5	3	•	•			•	•	•	•	•	
						3,5										
M8		M5	M6	M8	M6	4	•	•	•	•	•	•	•	•	•	
						4,5										
M10	M10	M6	M8	M10	M8	5	•	•	•	•	•	•	•	•	•	•
M12	M12 / M14	M8		M12 / M14	M10	6	•	•	•	•	•	•	•	•	•	•
M14			M10			7	•		•							
M16 / M18	M16 / M18	M10	M12	M16	M12	8	•	•	•	•	•	•	•	•	•	•
						9	•									
M20 / M22	M20 / M22	M12	M14	M18 / M20	M14 / M16	10	•		•	•		•	•	•	•	
M24 / M26 / M27	M24 / M26 / M27	M14	M16 / M18	M22 / M24	M18 / M20	12	•		•			•			•	
						12	•					•			•	
		M16 / M18	M20 / M22		M22 / M24	14	•		•			•				
M30 / M33	M30 / M33	M20 / M22	M24			17	•		•			•				
M36 / M38	M36	/ M38	M24 / M27			19	•		•			•				
M42 / M45	M42 / M45	M30				22	•									
M48 / M52	M48 / M52	M33				24	•									
		M36				27	•									
						30	•									
M56		M42				32	•									
		M48				36	•									

Vergleichstabelle von Innenvielzahn-Schrauben XZN mit Anwendungsempfehlungen für MATADOR-Schraubendreher-Einsätze und Winkelschraubendreher

Schrauben mit metrischem Gewinde	Schraubendreher-Einsätze			Winkel-Schraubendreher
	7059	3079	4079	
M5		•	•	•
M6		•	•	•
M8	•	•	•	•
M10	•	•	•	•
M12	•		•	•
M14			•	•
M16			•	

Vergleichstabelle von Innenkeilprofil-Schrauben RIBE CV mit Anwendungsempfehlungen für MATADOR-Schraubendreher-Einsätze und Winkelschraubendreher

Schrauben mit metrischem Gewinde	Schraubendreher-Einsätze	Winkel-Schraubendreher
M4		•
M5	•	•
M6	•	•
M8	•	•
M10	•	•
M12	•	•
M14	•	•
M16	•	•
M18		•

Vergleichstabelle von Innen-TORX®-Schrauben mit Anwendungsempfehlungen für MATADOR-Schraubendreher, -Einsätze und -Bits

Schrauben mit metrischem Gewinde							Blechschraben Ø mm			MATADOR - Schraubendreher-Einsätze, Bits					MATADOR-Schraubendreher				
A Flachkopfschrauben		E Zylinderschrauben		H Linsenschrauben															
B Zylinderschrauben		F Linsenschrauben		I Senkschrauben															
C Senkschrauben		G Senkschrauben		J Linsensenkschrauben															
D Linsensenkschrauben																			
A	B	C	D	E	F	G	H	I	J	Größe	mm	441 / 1	442	443	620	3092	4092	7025	7035
~ DIN 85	~ DIN 912	~ DIN 965	~ DIN 966	~ DIN 6912 7984	~ DIN 7985	~ DIN 7991	~ DIN 7981	~ DIN 7982	~ DIN 7983										
Speziialschrauben										T6	1,70								
Speziialschrauben										T7	1,99								
	M2,5	M2,5	M2,5		M2,5		2,9	2,9	2,9	T8	2,31								
							2,9			T9	2,50								
M3	M3	M3	M3	M3	M3	M3	3,5	3,5	3,5	T10	2,74								
M3,5		M3,5	M3,5		M3,5		3,9	3,9	3,9	T15	3,27								
M4	M4	M4	M4	M4	M4	M4	4,2	4,2	4,2	T20	3,86								
M5	M5	M5	M5	M5	M5	M5	4,8 / 5,5	4,8 / 5,5	4,8 / 5,5	T25	4,43								
Speziialschrauben										T27	4,99								
M6	M6	M6	M6	M6	M6	M6	6,3	6,3	6,3	T30	5,52								
M8	M8	M8	M8	M8	M8	M8				T40	6,65								
Speziialschrauben										T45	7,82								
M10		M10	M10	M10	M10	M10	M10			T50	8,83								
M12			M12		M12					T55	11,22								
M14			M14							T60	13,25								

Newton-Meter Nm in/to Kilopond-Meter kpm (1 Nm = 0.102 kpm)

Nm	0	10	20	30	40	50	60	70	80	90
0	0.00	1.02	2.04	3.06	4.08	5.10	6.12	7.14	8.16	9.18
100	10.20	11.22	12.24	13.26	14.28	15.30	16.31	17.33	18.35	19.37
200	20.39	21.41	22.43	23.45	24.47	25.49	26.51	27.53	28.55	29.57
300	30.59	31.61	32.63	33.65	34.67	35.69	36.71	37.73	38.75	39.77
400	40.79	41.81	42.83	43.85	44.87	45.89	46.91	47.93	48.95	49.97
500	50.99	52.00	53.02	54.04	55.06	56.08	57.10	58.12	59.14	60.16
600	61.18	62.20	63.22	64.24	65.26	66.28	67.30	68.32	69.34	70.36
700	71.38	72.40	73.42	74.44	75.46	76.48	77.50	78.52	79.54	80.56
800	81.58	82.60	83.62	84.64	85.66	86.68	87.70	88.71	89.73	90.75
900	91.77	92.79	93.81	94.83	95.85	96.87	97.89	98.91	99.93	100.95
1000	101.97	102.99	104.01	105.03	106.05	107.07	108.09	109.11	110.13	111.15

Newton-Meter Nm in/to Foot-Pounds lbf.ft. (1 Nm = 0.738 lbf.ft.)

Nm	0	1	2	3	4	5	6	7	8	9
0	0	0.47	1.48	2.21	2.95	3.69	4.43	5.17	5.90	6.46
10	7.38	8.12	8.86	9.59	10.33	11.07	11.81	12.54	13.28	14.02
20	14.76	15.50	16.24	16.97	17.71	18.45	19.19	19.93	20.66	21.40
30	22.14	22.88	23.62	24.35	25.10	25.83	26.57	27.31	28.04	28.78
40	29.52	30.26	31.00	31.73	32.47	33.21	33.95	34.69	35.42	36.16
50	36.90	37.64	38.38	39.11	39.85	40.59	41.33	42.07	42.80	43.54
60	44.28	45.02	45.76	46.49	47.23	47.97	48.71	49.45	50.18	50.92
70	51.66	52.40	53.14	53.87	54.61	55.35	56.09	56.83	57.56	58.30
80	59.04	59.78	60.52	61.25	62.00	62.73	63.47	64.21	64.94	65.68
90	66.42	67.16	67.90	68.63	69.37	70.11	70.85	71.59	72.32	73.06
100	73.80	74.54	75.28	76.01	76.75	77.49	78.23	78.97	79.70	80.44

Foot-Pounds lbf.ft. in/to Newton-Meter Nm (1 lbf.ft. = 12 lbf.in. = 1.356 Nm)

ft.-lbs.	0	1	2	3	4	5	6	7	8	9
0	0	1.36	2.71	4.07	5.42	6.78	8.14	9.49	10.85	12.20
10	13.56	14.92	16.27	17.63	18.98	20.34	21.70	23.05	24.41	25.76
20	27.12	28.48	29.83	31.19	32.54	33.90	35.26	36.61	37.97	39.32
30	40.68	42.04	43.39	44.75	46.1	47.46	48.82	50.17	51.53	52.88
40	54.24	55.60	56.95	58.31	59.66	61.02	62.38	63.73	65.09	66.44
50	67.80	69.16	70.51	71.87	73.22	74.58	75.94	77.29	78.65	80.00
60	81.36	82.72	84.07	85.43	86.78	88.14	89.50	90.85	92.21	93.56
70	94.92	96.28	97.63	98.99	100.34	101.70	103.06	104.41	105.77	107.12
80	108.48	109.84	111.19	112.55	113.90	115.26	116.62	117.97	119.33	120.68
90	122.04	123.40	124.75	126.11	127.46	128.82	130.18	131.53	132.89	134.24
100	135.60	136.96	138.31	139.67	141.02	142.38	143.74	145.09	146.45	147.80

Drehmoment-Umrechnungsfaktoren / Torque Reduction Factors (conversion rates)

Gegebene Maßeinheit x Faktor = gewünschte Maßeinheit / Dimension given x factor = dimension desired						
Gegebene Maßeinheit	Gewünschte Maßeinheit					
	Dimension desired					
	= Ncm	= Nm	= kpcm	= kpm	= lbf.in.	= lbf.ft.
Ncm	1	0,01	0,10197	0,00102	0,0885	0,00738
Nm	100	1	10,197	0,10197	8,851	0,7376
kpcm	9,807	0,9807	1	0,01	0,868	0,0723
kpm	980,7	9,807	100	1	86,796	7,233
lbf.in.	11,298	0,11298	1,152	0,01152	1	0,0833
lbf.ft.	135,58	1,3558	13,825	0,13825	12	1

Änderungen und Irrtum vorbehalten.

PHILLIPS RECESS® ist ein eingetragenes Warenzeichen der Firma Phillips Screw Company. PHILLIPS RECESS® is a registered trademark of Phillips Screw Company.

POZIDRIV® ist ein eingetragenes Warenzeichen der Firma European Industrial Services Ltd. POZIDRIV® is a registered trademark of European Industrial Services Ltd.

RIBE® ist ein eingetragenes Warenzeichen der Firma Richard Berger. RIBE® is a registered trademark of Richard Berger.

XZN® ist ein eingetragenes Warenzeichen der Firma Bauer + Schaurte. TORX® is a registered trademark of Bauer + Schaurte.

TAMPER TORX® ist ein eingetragenes Warenzeichen der Firma CAMCAR/TEXTRON INC. TAMPER TORX® is a registered trademark of CAMCAR/TEXTRON INC.

TORX® ist ein eingetragenes Warenzeichen der Firma CAMCAR/TEXTRON INC. TORX® is a registered trademark of CAMCAR/TEXTRON INC.

Allgemeine Verkaufs- und Lieferbedingungen

Allgemeine Verkaufs- und Lieferbedingungen der MATADOR GmbH & Co. KG

§ 1 Geltungsbereich

1. Unsere Allgemeinen Geschäftsbedingungen (AGB) gelten ausschließlich. Entgegenstehende oder von unseren AGB abweichende Bedingungen des Bestellers erkennen wir nicht an, es sei denn, wir haben ausdrücklich schriftlich ihrer Geltung zugestimmt. Unsere AGB gelten auch dann, wenn wir in Kenntnis entgegenstehender oder von unseren AGB abweichender Bedingungen des Bestellers die Lieferung an den Besteller vorbehaltlos ausführen. Unsere AGB gelten auch für alle gegenwärtigen und zukünftigen Geschäftsbedingungen mit dem Besteller.
2. Alle Vereinbarungen, die zwischen uns und dem Besteller zwecks Ausführung dieses Vertrages getroffen werden, sind in diesem Vertrag schriftlich niedergelegt.
3. Unsere AGB gelten nur gegenüber Unternehmen im Sinne von § 310 BGB.

§ 2 Angebot und Vertragsschluss

1. Alle Angebote sind freibleibend bezüglich Preisstellung und Liefermöglichkeiten.
2. Alle Aufträge gelten erst nach Erteilung unserer schriftlichen Bestätigung als angenommen. Entsprechendes gilt auch für Ergänzungen und Abänderungen.
3. Die in Prospekten, Katalogen, Preislisten oder den zum Angebot gehörenden Unterlagen enthaltenen Angaben, Zeichnungen, Abbildungen und Leistungsbeschreibungen sind unverbindlich, es sei denn, sie werden in der Auftragsbestätigung ausdrücklich als verbindlich bezeichnet.
4. Die genannten Dokumente unterliegen dem Urheberrecht.
5. Der Vertragsschluss gilt vorbehaltlich der rechtzeitigen und richtigen Selbstbelieferung durch unsere Zulieferer. Der Kunde wird über die Nichterfüllung unverzüglich informiert, bereits erbrachte Gegenleistungen werden erstattet.

§ 3 Sonderanfertigungen

1. Sofern wir Sonderanfertigungen nach den Vorgaben des Bestellers liefern, übernimmt dieser die Gewähr dafür, dass Schutzrechte Dritter nicht verletzt werden. Der Besteller haftet für inhaltliche Richtigkeit, technische Durchführbarkeit und Vollständigkeit.
2. Bei Sonderanfertigungen behalten wir uns eine Mehr- oder Minderlieferung bis zu 10 % vor. Der Rücktritt des Bestellers vom Vertrag oder die Rückgabe besonders gefertigter Ware kann von uns nicht akzeptiert werden.

§ 4 Preise, Mindestauftragswert / Bearbeitungsgebühr

1. Sofern sich aus unserer Auftragsbestätigung nichts anderes ergibt, gelten unsere in € ausgewiesenen Preise "ab Werk" einschließlich Verladung im Werk. Sie verstehen sich ohne Verpackung, Fracht, Versicherung, Zoll oder sonstige Spesen. Diese werden gesondert in Rechnung gestellt.
2. Die gesetzliche Mehrwertsteuer ist nicht in unseren Preisen eingeschlossen. Sie wird in gesetzlicher Höhe am Tag der Rechnungsstellung in der Rechnung gesondert ausgewiesen.
3. Die genannten Preise basieren auf den zu diesem Zeitpunkt gegebenen Fertigungskosten. Im Falle einer Kostensteigerung aufgrund der allgemeinen Entwicklung der Lohn-, Material- oder sonstiger Produktionskosten müssen wir uns vorbehalten, die zum Zeitpunkt der Lieferung gültigen Preise anzurechnen, sofern nicht ausdrücklich Festpreise vereinbart worden sind.
4. Sind bestimmte Preise nicht vereinbart, so gelten die zum Zeitpunkt der Auslieferung gültigen Preise.
5. Der Mindestauftragswert beträgt EUR 50,- netto. Bei Aufträgen mit einem Wert unter EUR 50,- netto berechnen wir eine Bearbeitungsgebühr von EUR 7,50 zzgl. MwSt. und Porto.

§ 5 Zahlungsbedingungen

1. Zahlungen innerhalb von 10 Tagen nach Rechnungsdatum berechtigen zu einem Abzug von 2% Skonto auf den Warenwert. Zahlungen innerhalb von 30 Tagen können nur netto akzeptiert werden.

2. Wechsel- und Diskontspesen gehen zulasten des Bestellers und sind sofort zu begleichen.
3. Bei Zielüberschreitungen müssen wir uns die Berechnung von Verzugszinsen auf der Basis des jeweils gültigen Zinssatzes vorbehalten.
4. Im Falle von Zahlungsverzug, eingehendem Wechselprotest oder einer wesentlichen Verschlechterung der Vermögensverhältnisse seitens des Bestellers sind wir berechtigt, für laufende Verträge weitere Sicherheiten zu verlangen oder vom Vertrag zurückzutreten. Außerdem behalten wir uns in diesen Fällen vor, weitere Leistungen nur gegen Vorkasse zu erbringen sowie die sofortige Einlösung von Akzepten, Wechseln und Schecks zu verlangen.

§ 6 Lieferzeit

1. Die Lieferzeit gilt als annähernd vereinbart, sofern nicht ausdrücklich ein fester Termin vereinbart wurde.
2. Bei späteren Änderungen des Vertrages durch den Besteller, die die Lieferzeit beeinflussen, kann sich die Lieferfrist in angemessenem Umfang verändern.
3. Liefer- und Leistungsverzögerungen, die nicht von uns zu vertreten sind, dazu gehören insbesondere höhere Gewalt, Streik, Aussperrung, behördliche Anordnungen etc. berechtigten uns, die Lieferung um die Dauer der Behinderung hinauszuschieben.

§ 7 Lieferung

1. Inlandslieferungen erfolgen "ab Werk", sofern der Auftragswert unter EUR 150,- liegt. Bei Postsendungen erfolgen Lieferungen ebenfalls "ab Werk".
2. Exportlieferungen erfolgen normalerweise frei Grenze bzw. FOB deutschem Hafen einschließlich Verpackung.
3. Alle Lieferungen erfolgen stets auf Rechnung und Gefahr des Bestellers. Für Verluste und Beschädigungen auf dem Transportweg besteht keine Ersatzpflicht.
4. Verpackung wird zum Selbstkostenpreis berechnet, aber nicht zurückgenommen. Die Entsorgungskosten trägt der Besteller.

§ 8 Mängelanzeige

Es gelten die gesetzlichen Untersuchungs- und Rügepflichten. Die Mängelanzeige muss schriftlich und unverzüglich, spätestens innerhalb von fünf Tagen nach Erhalt der Ware erfolgen. Maßgeblich ist der rechtzeitige Eingang bei uns.

§ 9 Gewährleistung

1. Für nicht durch uns zu vertretende Schäden aus unsachgemäßer Verwendung, fehlerhafter Montage / Inbetriebsetzung oder Veränderung gelieferter Ware, natürliche Abnutzung oder fehlerhafte Behandlung können wir keine Gewähr übernehmen.
2. Ist die gelieferte Ware mangelhaft oder fehlen ihr zugesicherte Eigenschaften, so verpflichten wir uns nach unserer Wahl und unter Ausschluss weiterer Gewährleistungsansprüche des Bestellers zur Nachbesserung oder Ersatzlieferung.
3. Die Feststellung solcher Mängel muss uns unverzüglich - bei erkennbaren Mängeln spätestens binnen 5 Tagen nach Erhalt der Ware, bei verborgenen Mängeln unverzüglich nach Erkennbarkeit - schriftlich mitgeteilt werden.
4. Als Beschaffenheit der Ware gilt grundsätzlich nur die Produktbeschreibung des Herstellers als vereinbart. Darüber hinaus gehende öffentliche Äußerungen stellen keine vertragsgemäße Beschaffenheitsangabe dar.
5. Gewährleistungsansprüche sowie Ersatzansprüche wegen Mangelfolgeschäden verjähren nach einem Jahr ab Ablieferung der Ware.

§ 10 Garantie

Alle Werkzeuge unterliegen einer vollen Garantie. Für jedes Werkzeug, das durch Fehler in der Verarbeitung oder im Material unbrauchbar wurde, leisten wir kostenlosen Ersatz, sofern die Untersuchung in unserem Werk nicht ergibt, dass das Werkzeug unsachgemäß behandelt oder in seinen Maßen verändert wurde oder natürliche Abnutzung vorliegt. Beanstandete Stücke sind einzusenden.

§ 11 Gesamthaftung

1. Bei leicht fahrlässiger Verletzung wesentlicher Vertragspflichten ist unsere Haftung auf den nach Art der Ware vorhersehbaren, vertragstypischen Durchschnittsschaden beschränkt. Bei leicht fahrlässiger Verletzung unwesentlicher Vertragspflichten ist unsere Haftung ausgeschlossen. Etwaige Ansprüche aus Produkthaftung sind hiervon nicht betroffen. Des Weiteren gelten die Haftungsbeschränkungen nicht für uns zurechenbare Gesundheitsschäden des Kunden.
2. Schadensersatzansprüche wegen Mangels verjähren nach einem Jahr ab Warenlieferung. Dies gilt wiederum nicht bei grobem Verschulden unsererseits sowie bei uns zurechenbaren Gesundheitsschäden des Kunden.

§ 12 Retouren

1. Warenrücknahmen sind grundsätzlich nur nach vorheriger Absprache bzw. Genehmigung durch uns möglich. Die Annahme von Warenrücksendungen ohne unsere Genehmigung wird verweigert.
2. Die Rücksendung hat grundsätzlich für uns frachtfrei zu erfolgen.
3. Eine Bearbeitungsgebühr i. H. v. 20% des Warenwertes wird in Abzug gebracht.

§ 13 Eigentumsvorbehalt

1. Bis zur vollständigen Bezahlung der aus der Geschäftsverbindung resultierenden Gesamtforderung bleibt die Ware unser Eigentum (Vorbehaltsware). Akzeptierte, Wechsel und Schecks gelten erst nach ihrer Einlösung als Bezahlung.
2. Bei Zahlungsverzug oder Vermögensverfall des Bestellers sind wir berechtigt, die sofortige Auslieferung der Vorbehaltsware zu verlangen. Alle befristeten Forderungen an den Besteller werden dann sofort fällig. Hereingegebene Wechsel sind, unabhängig von ihrer Fälligkeit, Zug um Zug gegen Bargeld einzulösen.
3. Der Besteller verpflichtet sich, die Vorbehaltsware pfleglich zu behandeln und auf eigene Kosten ausreichend zu versichern.
4. Pfändungen der Vorbehaltsware sind uns unverzüglich unter Beifügung des Pfändungsprotokolls zu melden.
5. Der Besteller ist berechtigt, über die Vorbehaltsware im ordentlichen Geschäftsverkehr zu verfügen. Nicht gestattet sind Verpfändungen oder Sicherungsübereignungen sowie Weiterverkauf nach erfolgter Zahlungseinstellung. Bei Veräußerung der Vorbehaltsware auf Kredit durch den Besteller gelten die sich daraus ergebenden Kaufpreisforderungen im Moment ihrer Entstehung als an uns abgetreten. Der Besteller ist so lange berechtigt, die Forderungen einzuziehen, bis dies aufgrund eines Zahlungsverzugs oder Vermögensverfalls durch uns untersagt wird. In diesem Falle hat uns der Schuldner auf Verlangen eine Abtretungserklärung in 2-facher Ausfertigung über jede einzelne Forderung auszuhandigen.
6. Wird die Kaufsache mit anderen, uns nicht gehörenden Gegenständen verarbeitet, so erwerben wir das Miteigentum an der neuen Sache in entsprechendem Verhältnis zu den anderen verarbeiteten Gegenständen.

§ 14 Erfüllungsort, Gerichtsstand, anzuwendendes Recht, Teilnichtigkeit

1. Erfüllungsort für Lieferung und Zahlung ist Remscheid. Allgemeiner Gerichtsstand für Streitigkeiten aller Art aus dem Liefervertrag ist das Amtsgericht Remscheid bzw. das Landgericht Wuppertal. Die Bestimmungen des § 38 ZPO gelten als vorrangig. Das Vertragsverhältnis untersteht deutschem Recht unter Ausschluss des einheitlichen UN-Kaufrechts.
2. Sollte eine Bestimmung dieser Bedingungen ganz oder teilweise unwirksam oder nichtig sein oder werden, werden die übrigen Bestimmungen davon nicht berührt. Die unwirksame Bestimmung wird durch die entsprechende gesetzliche Regelung ersetzt.

General Terms and Conditions of MATADOR GmbH & Co. KG

§ 1 Scope

1. Our General Terms and Conditions are exclusively valid. We do not accept any regulations to the contrary or regulations that differ from our terms and conditions, unless we expressly agreed to them in written form. Our General Terms and Conditions are even valid if we execute orders without reservation despite being aware of alternative conditions on the part of the customer. All present and future business connections to the customer are subject to our General Terms and Conditions.
2. All agreements between the customer and us with regard to the execution of this contract are put into writing in this contract.
3. Our General Terms and Conditions are only valid for contracts with entrepreneurs in terms of § 310 German Civil Code.

§ 2 Quotations and Conclusion of the Contract

1. All quotations are without engagement regarding prices and possibilities for delivery.
2. All orders are only to be regarded as accepted after we have given our confirmation in written form. The same applies to additions and changes of orders.
3. The details, drawings, illustrations and performance descriptions contained in brochures, catalogues, price lists or other documentations that are part of a quotation are without engagement unless we expressly refer to them as being binding in our order confirmation.
4. All the documents mentioned are subject to our copyright.
5. The conclusion of the contract is effective subject to our timely and correct provision by our suppliers. The customer will immediately be informed about the default and payments already made will be refunded.

§ 3 Custom-made products

1. If we deliver articles that are made to customer's specifications the customer is responsible for ensuring that industrial property rights of third parties are protected. The customer is responsible for the correctness of the contents, their technical practicability and completeness.
2. In case of custom-made products we reserve the right to increase or reduce the quantity delivered by up to 10%. In case of especially manufactured articles we cannot accept a withdrawal from the contract or a return of the custom-made articles by the customer.

§ 4 Prices, Minimum Order Value / Handling Fee

1. Our prices are quoted in € and ex works unless stated differently in our order confirmation. They do not include packaging, freight, insurance, customs and other charges. They are invoiced separately.
2. Our prices are quoted exclusive of VAT. VAT is shown separately in the invoice.
3. The prices quoted are based on the production costs that apply at the date of the quotation. In the case of an increase in production costs due to a general increase in wage, material or other production costs we have to reserve the right to charge the prices that apply at the date of the delivery unless fixed prices are expressly agreed upon.
4. The minimum order value is € 50 net. For orders with a value of less than € 50 we charge a handling fee of € 7.50 plus VAT and postal charges.

§ 5 Payment

1. For payments within 10 days following the date of the invoice we grant a cash discount of 2% on the value of the goods. Payments within 30 days can only be accepted net.
2. Note charges and discount charges will be paid by the customer and are to be settled immediately.
3. In case of delayed payment we have to reserve the right to charge interests for delay on the basis of the interest rate valid at that time.
4. In case of delayed payment, incoming note protests or a considerable aggravation of the financial circumstances on the part of the customer we are entitled to demand other securities

for current contracts or to cancel the contract. Moreover we reserve the right to render further services only on the basis of advance payment and to demand immediate payment of acceptances, bills of exchange or checks.

§ 6 Delivery Period

1. Delivery dates are to be regarded as approximately agreed upon unless a fixed date is stipulated.
2. In case of subsequent modifications of the contract by the customer that influence the delivery period, this period may change to an appropriate extent.
3. Delays in delivery or service that can not be attributed to us entitle us to postpone delivery by the duration of the obstruction. This is especially valid in case of force majeure, strike, lock-out, official directive etc.

§ 7 Delivery

1. Domestic deliveries are made ex works when the order value is below € 150. Deliveries by mail are also made ex works.
2. Export shipments are normally made free border or FOB German port respectively, packing included.
3. All deliveries are always made for the account and at the risk of the customer. MATADOR will not be responsible for any losses or damage that occur during transport.
4. Packing will be charged at cost price and is non-returnable. The customer bears the disposal costs.

§ 8 Notice of Defect

The notice of defect has to be sent to us immediately in written form and not later than 5 days after receipt of the goods.

§ 9 Warranty

1. For damage due to improper use, incorrect assembly / operation or modification of the goods delivered, wear and tear or incorrect handling we cannot assume liability.
2. If the goods delivered are defective or lack guaranteed characteristics we commit ourselves - at our own choice and excluding further warranties for defect - to repair or to replace the imperfect goods.
3. The customer has to inform us about defects immediately and in written form. In case of noticeable defects we have to be notified within five days after receipt of the goods, in case of hidden defects we have to be informed immediately after they have been discovered.
4. The manufacturer's product description solely specifies the good's characteristics. Additional comments made in public are not part of the contractual product description.
5. Warranty claims and claims for compensation due to consequential harm caused by a defect become time-barred after one year following delivery of the goods.

§ 10 Guarantee

All tools are subject to a full guarantee. We will replace every tool free of charge that has become unusable due to faulty workmanship or material. If testing in our plant, however, shows that the tools have been handled in an improper way, that their measurements have been changed or that their defects are due to wear and tear they cannot not be replaced free of charge. Rejected items are to be returned.

§ 11 Overall Commitment

1. In case of negligent violation of essential contractual obligations our liability is limited to the - according to the kind of good - predictable and typical average damage. In case of negligent violation of insignificant contractual obligations our liability is excluded. Warranty claims are not affected by this regulation. Moreover the limitation of our liability is not valid for damage caused to the customer's health that can be attributed to us.
2. Claims for damage due to defects become time-barred after one year following delivery of the goods. Again this does not apply in case of gross negligence on our part or in case of damage caused to the customer's health that can be attributed to us.

§ 12 Return of Goods

1. Basically, returns of goods are only possible after prior accord or after we have given our approval. We cannot accept returns that are made without our prior approval.
2. In any case goods have to be returned carriage paid.
3. We will charge a handling fee of 20% of the value of the goods.

§ 13 Reservation of Property Rights

1. Until the total claim resulting from the business connection will have completely been paid the goods remain our property. Acceptances, bills of exchange and checks are only to be regarded as payment after being honoured.
2. In case of a delay in payment or financial collapse we are entitled to demand the immediate handing over of the goods subject to our property rights. All fixed-term claims towards the customer become immediately due. Irrespective of their maturity date bills of exchange are to be honoured immediately.
3. The customer commits himself / herself to treat the goods subject to our property rights carefully and to insure them adequately.
4. Distraints of the goods subject to our property rights have to be reported to us immediately and the bailiff's return has to be enclosed.
5. The customer has the goods subject to our property rights at his / her disposal within the scope of ordinary business. After having suspended payment it is not permitted to mortgage, resell or assign the goods subject to our property rights as securities. If the customer sells the goods subject to our property rights on credit the title to claims that arises is to be regarded as immediately transferred to us. The customer is authorized to receive the payments out of this resale as long as this is not prohibited by us due to delays in payment or a financial collapse on the part of the customer. In this case the debtor has to deliver a declaration of transfer in duplicate about each claim on request.
6. If the article bought from MATADOR is compounded with other articles that are not part of our property we acquire joint ownership of the product in proportion to the other articles used.

§ 14 Place of Performance, Jurisdiction, Applicable Law, Partial Invalidity

1. Place of delivery and payment is Remscheid. The general place of jurisdiction for disputes of all kinds related to the contract is the Local Court in Remscheid or the Regional Court in Wuppertal. Priority is to be given to the regulations of § 38 ZPO. The contractual relationship is subject to German law excluding the regulations of the United Nations Convention on Contracts for the International Sale of Goods.
2. Should any regulation of these General Terms and Conditions be or become partly or fully ineffective or void this does not affect the validity of the other regulations. The ineffective regulation will be replaced by the appropriate legal regulation.

Inhaltsverzeichnis Deutsch / Index German

	Seite		Seite		Seite
	Page		Page		Page
A		Drehstifte	44	Henkellocheisen	88
Abisolierzange	54, 61	Dreikanthohlschaber	117	Holzheft-Schraubendreher	68, 69
Absetzzange	175	Dreikantlöffelschaber	117		
Abzieher	92 - 94, 97, 179, 207	Durchlaufschere	176	I	
Achsmutterschlüssel	218	Durchsteckknarre	140, 153	Injektorschlüssel	216
Adapter	28, 77, 78, 126, 134, 144, 154, 156	Durchtreiber	90, 91	Innenaudreher	97
Adapter-Satz MTS	126	Düseneinsteller Waschanlage	179		
Aderendhülsen-Zange	53	Düsen-Werkzeuge	216 - 217	K	
Arretierdorne	205, 206	E		Kabelmesser	103
Aufspreizer	189	Eckrohrzangen	57	Kabelschneider	52, 60
Ausbeulhammer	86	Einschnittgewindebohrer-Bits	99	Kardangelen	113, 125, 133, 143, 154
Ausbeulwerkzeug	173, 174	Einspritzdüseneinsätze	216, 217	Karosserie-Blechmeißel	176
Ausdreher	98	Einsteck-Drehmomentschlüssel	112 - 115	Karosserie-Feilenhalter	175
Ausglaswerkzeug	179	Einsteck-Gelenkgriff	112	Karosserie-Werkzeuge	170 - 177
Auspuff-Klemmfedernspanner	190	Einsteck-Kardangelen	113	Kerbzahn-Einsatz für Vorkammern	220
Auspuff-Ziehaken	190	Einsteck-Maulschlüssel	114	Ketten-Rohrabschneider	102, 191
Auswuchtgewichtzange	186	Einsteck-Ringratschenschlüssel	114, 115	Kfz-Spezialwerkzeuge	168 - 220
Autolichtprüfer	75, 194	Einsteck-Umschaltknarre	113	Klauenschlüssel	219
Axial-Gripzange	171 - 173	Elektroniker-Schraubendreher	28, 73	Klemmleiste	127, 129, 135, 136, 145, 203
		Elektronik-Seitenschneider ESD	53	Klemmmutterschlüssel	218
B		Elektronik-Spitzzange ESD	53	Kneifzangen	53
Bandmaß	104	Endoskop	207	Kolbenring-Spannbänder	208
Batterie-Polklemmenbürste	195	Entriegelungssätze	29, 196, 197	Kolbenring-Zangen	208
Batterietester	194			Kontaktfeilen	101
Batteriesäure-Füller	195	F		Körner	90, 91
Batteriesäure-Prüfer	195	Fahrwerk-Werkzeuge	188, 189	Kraft-Einsätze	158 - 167
Biegeisen	174	Fahrzeugelektronik-Werkzeuge	196 - 200	Kraft-Kardangelen	160, 163, 166
Bithalter	81, 82	Fäustel	87	Kraft-Kombinationszangen	50, 54, 55, 60, 61
Bits	29, 78 - 83	Federbeineinsatz XZN	189	Kraft-Seitenschneider	52, 54
Bit-Sortimente	81 - 83	Federspanner	188	Kraft-Sicherungsringe	167
Blechknabber	175	Feilen	13, 99, 101	Kraft-Sicherungsstifte	167
Blechmeißel	176	Fettpresse	119	Kraft-Verbindungsstücke	158, 159, 163, 165
Blindniethandzange	177	Fixierschraube	205	Kraft-Verlängerungen	158, 159, 163, 166
Bohrer	120, 176	Flachmeißel	13, 89, 91	Krähen-Fuß-Schlüssel	137, 218
Bolzenschneider	52	Flachschaber	118	Krallengreifer	116
Bördelgeräte	103	Flachsteckwerkzeuge	198	Kreuzmeißel	89
Bremseinstellschlüssel	181	Flachzange	186	Kreuzschlüssel	184, 185
Bremsen-Entlüftungsschlüssel	180	Frostschutzprüfer	195	Kriech- und Haffett	203
Bremsenreiniger	183, 184	Fühlerlehren	23, 104	Kugelgelenk-Ausdrücker	95, 96
Bremsen-Servicesatz	184	G		Kühlsystem-Werkzeuge	195
Bremsen-Werkzeuge	180 - 184	Gabelsteckwerkzeuge	198, 199	Kurbel	133, 143
Bremsfedernzange	181, 182	Gegenhalteschlüssel	206	L	
Bremskolbenrückstellsatz	29, 181	Gelenkgriffe	112, 133, 143	Lambdasonden-Einsätze	191
Bremsleitungsschlüssel	180, 184	Gerüstbauknarre	156	Langbeck-Flachzange	50, 60
Bremssattelbürste	183, 184	Gewindefeilen	99	Langbeck-Rundzange	50, 60
Bremssattelzeile	183, 184	Gewindereparaturwerkzeug	99, 100	Leckölzange	216
Bremseilfedernzange	182	Gewindeschablonen	23, 104	LED-Arbeitsleuchte	121
Bürsten	116	Glasschaber	178	Leermodul	19, 23
		Gleitgriff	125, 132, 142, 153, 156	Lichtmaschinen-Montagewerkzeug	201
D		Glühkerzen-Auszieher	215	Lochblechschere	175
Diamant-Schraubendreher	76	Glühkerzen-Einsätze	28, 138, 214	Loch- und Absetzzange	175
Dichtungsschaber	13, 118, 178	Glühkerzen-Gewindereparatursatz	215	Löffeisen	172
Distanzmodul	19	Glühkerzen-Ringratschenschlüssel	215	Luffilterschlüssel Nfz	210
Doppelgelenk-Steckschlüssel	44	Gripzangen	58, 59		
Doppelmaulschlüssel	10, 13, 18, 23, 36, 37	Gummihämmer	87	M	
Doppelring-Ratschenschlüssel	43	H		Magnet-Haftschale	121
Doppelringschlüssel	10, 13, 18, 21, 23, 41, 42, 44	Haarlineal	23, 105	Magnetheber	116
Doppelringschlüssel, offen	180	Hämmer	23, 86, 87	Magnetschlüssel	37
Doppelsteckschlüssel, massiv	44	Handfäuste	173	Messschieber	23, 106
Drehmomentschlüssel	23, 107 - 110, 112, 113	Handhebel fettpresse & Zubehör	119	Metallsägebogen	117
Drehmoment-Schraubendreher	115	Hebelblechschere	176		
Drehmomenttester	111	Hebeleisen	187		
Drehmomentvervielfältiger	111				

	Seite Page		Seite Page		Seite Page
Module für Wertstattwagen	10 - 13	Schlosserhämmer	13, 86, 87	V	
Montagekeile	177	Schlüssel	36 - 47	VDE-Werkzeuge	10, 11, 18, 19
Montagezangen	56	Schlüsselfeilen	101		60, 61, 72
Motorsteuerungswerkzeuge	201 - 207	Schlüsselhalter	47	Ventildichtring-Zange	208
Mutternsprenger	99	Schlüssel Turboladerverschraubung	203	Ventileinschleifer	208
N		Schnellanschlusszange	216	Verbindungsstücke	77, 78, 126, 134
Nfz-Werkzeuge	218 - 220	Schonhämmer	86		144, 154, 156
Nockenwellen-Abzieher	207	Schraubenausdreher	28, 98, 159	Vergaser-Schraubendreher	76
Nockenwellen-Arretierung	204 - 206	Schraubendreher	11 - 13, 19 - 25	Verlängerungen	125, 132, 133, 142
Nockenwellen-Einsatz XZN	205		64 - 83		154, 157
Nockenwellen-Lineale	204, 205	Schraubendreher, umsteckbar	28, 71, 77	Viscolüfterschlüssel	202
O		Schraubendreher-Einsätze	11, 19, 21, 22	Vornschneider	52
Öldienstschlüssel	209		127 - 129, 135 - 137		
ÖlfILTER-Bandschlüssel	209	Schraubendreher-Einsätze, 5-Stern	203	W	
ÖlfILTER-Einsätze	211	Schraubendreher TX 8, Spezial	178	Wasserpumpenzangen	54, 55
ÖlfILTER-Kettenschlüssel	210	Schraubstöcke	119	Wasserwaage	23, 105
ÖlfILTER-Schlüssel	210, 211	Schweißpunktbohrer	176	Werkstattfeilen	101
Ölkanne	118	Schweißpunktfräser	120, 176	Werkstattwagen & Zubehör	8 - 33
Ölstift	118	Schwungrad-Blockierwerkzeug	207	Werkstattwinkel	23, 105
P		Sechskant-Steckschlüssel	71	Werkzeughalter	98
Pfeifenkopfschlüssel	45	Seitenschneider	51, 52, 55, 60, 61	Werkzeugkoffer & Zubehör	222
Pneumatik-Spotle-Bohrer	120	Sicherheitsmesser	103	Werkzeugsortimente	221 - 225
PTFE-Fett-Spray	203	Sicherungsringzangen	10, 18, 21, 56, 57	Werkzeugtaschen	223
R		Sondersteckwerkzeuge	200	Werkzeugtrolley	224
Rabitzzangen	53	Spannkeile	190	Winkelscheiben, mechanisch	111
Räder-Werkzeuge	185 - 187	Spannschlüssel	202	Winkelschraubendreher	64 - 68, 75
Radlagerwerkzeug-Satz	189	Spannungsprüfer	72, 194		
Radmütterschlüssel	184, 185	Spinttreiber	13, 90, 91, 182	Z	
Refraktometer	195	Stahldrahtbürste	13, 116	Zahnriemen-Schlüssel	202
Reifenmontierhebel	23, 186, 187	Stahlmaßstäbe	104, 105	Zahnriemen-Spannungsprüfer	206
Reifenprofil-Tiefenmesser	186	Starter- und Blockschlüssel	42	Zahnriemen-Werkzeug	204
Reißnadel	23, 106	Steckgriff	126	Zangen	10, 12, 13, 18, 20 - 22,
Riemenscheiben-Abzieher	201	Steckschlüssel	70, 71, 124 - 167		24, 25, 50 - 61, 208, 213, 216
Riemenscheiben-Schlüssel	201, 202	Steckschlüssel-Einsätze	127, 129 - 131	Zapfenschlüssel	219
Ringmaulschlüssel	10, 12, 13, 18		134 - 136, 138, 139, 144, 145	Zapfenschlüssel für Einspritzdüsen	217
	20, 22 - 24, 38, 40	Steckschlüssel-Garnituren	11, 12, 19 - 22	Zug-Ringschlüssel	47
Ring-Maul-Ratschenschlüssel	39		24, 25, 130, 131	Zünd- und Glühkerzen	213 - 215
Ringratschenschlüssel	10, 18, 21	Steckwerkzeuge	198 - 200	Zündkerzenabzieher	213
Ringratschenschlüssel, gekröpft	43	Stehbolzen-Ausdreher	98	Zündkerzenbürste	116, 213
Ringschlüssel	23	Stiftleuchte	121	Zündkerzeneinsätze	136, 148, 214
Ringschlüssel, offen	10, 18	Stockschraubenschlüssel	37	Zündkerzenschlüssel	212
Ringschlüssel für Einspritzpumpe	203	Sturz-Einstellwerkzeug	188	Zündkerzenstecker-Zange	213
Rohrabschneider	102, 191	T		Zylinderkopf-Schlüssel	161
Rohrsteckschlüssel	45, 220	Taschenmessschieber	23, 106		
Rollgabelschlüssel	39	Telefonzangen	50, 51, 55, 61		
Rostlöser	183	Teleskopspiegel	120		
Rundsteckwerkzeuge	200	T-Griff	125, 126, 133, 143		
S		Tischklammer für Gripzangen	58		
Saugheber	179	TIN-Bit-Sortimente	82		
Schaber	117, 118, 178	Treibhammer	86		
Scheiben-Austrennmesser	178	Trenngabeln	96		
Scheibenwischerarm-Abzieher	179	Türbolzen-Ausziehgerät	170		
Schlagbuchstaben / -ziffern	88	Türeinsteckschlüssel	171		
Schlag-Maulschlüssel	46	Türfedernzange	171		
Schlag-Ringschlüssel	46	Türscharnier-Einsteckwerkzeug	170		
Schlag-Schraubendreher	77	Türscharnier-Knarrensatz	170		
Schlauchklemmen-Vorrichtung	193	Türverkleidungs-Lösewerkzeug	171, 177		
Schlauchklemmenzange	192, 193	U			
		Umschaltknarren	29, 113, 124, 132		
			140, 141, 153, 156		
		Umsteckschraubendreher	28		

Inhaltsverzeichnis Englisch / Index English

	Seite Page		Seite Page		Seite Page
A		Crow Foot Spanners	137, 218	H	
Adapters	28, 77, 78, 126, 134	Crown Sockets	217, 220	Hacksaws	117
	144, 154, 156	Cutter	103	Hammers	23, 86, 87
Adjustable Wrenches	39	Cylinder Head Wrench	161	Hand Anvils	173
Angle Dials	111			Handriveter	177
Antifreeze Tester	195	D		Hardshell Case	222
Arch Punches	88	Desk Clamp Pliers	58	Heavy Duty Combinations Pliers	50, 60
Axial Grip Pliers	171 - 173	Diamond Grip Screwdrivers	76	Heavy Duty Ring Spanners	47
Axle Nut Wrench	218	Distance Module	11, 19	Heavy Duty Side Cutters	52
		Door Adjusting Wrench	171	Hexagon Key Wrenches	64 - 68, 75
B		Door Hinge Wrenches	170	Hexagon Nut Drivers	70, 71
Balancing Weight Plier	186	Door Panel Tools	177	Hexagon Sockets	127, 129 - 131
Ball Joint Pullers	95, 96	Door Spring Pliers	171		134 - 136, 138, 139, 144, 145
Battery Acid Tester / Filler	195	Door Spring Plier	171		147, 148, 150 - 152, 154, 155, 157
Battery Cell Tester	194	Double Box Wrenches	43	Holder for Wrenches	47
Battery Terminal Brush	195	Double Ended Ring Spanners	10, 13, 18	Hole Cutting Snips	175
Belt Pulley Wrenches	201, 202		21, 23, 41, 42, 44	Hose Clamp Pliers	192, 193
Bitholders	81, 82	Double Ended Swivel Spanners	44		
Bits	29, 78 - 83	Double Open Ended Midget Spanners	37	I	
Bits Assortments	81 - 83	Double Open Ended Spanners	10, 13	Idler Pulling Wrenches	202
Body and Fender Spoons	174		18, 23, 36	Impact Extensions	158, 159, 163, 166
Body and Fender Tools	173, 174	Double Ring Ratchet Spanners	43	Impact Puller for door hinge bushes	
Body Chisels	176	Drain Plug Wrenches	209	Impact Retaining Pins and Rings	167
Body Work File Holder	175	Drift Punches	90, 91	Impact Screwdrivers	77
Bolt Cutters	52	Drills	120, 176	Impact Sockets	158 - 167
Box Spanners	44			Impact Socket Converters	158, 159
Brake Adjusting Spanner	181	E			163, 165
Brake Bleeding Wrenches	180	Electrician's Screwdrivers	73	Impact Universal Joint	160, 163, 166
Brake Caliper Brush	183	Electronic Caliper	106	Injection Nozzle Sockets	216, 217
Brake Caliper File	183	Electronic Nose Pliers	53	Injection Pipe Spanners	216
Brake Caliper Tool Kit	29, 181	Electronic Side Cutter	53	Injection Pump Wrench	202
Brake Cleaner	183	Electronic Torque Wrenches	110	Insert Tools	113 - 115
Brake Spring Pliers	181, 182	End Cutting Nipper	52	Internal Pullers	97
Brass Tyre Profile Depth Gauge	186	Endoscope	207		
Brushes	116	Engineers' Files	101	K	
		Engine Tools	201 - 207	Key Wrenches	64 - 68, 75
C		Exhaust System Tools	190		
Cable Cutter	52, 60	Expander	189	L	
Cable Knife	103	Extensions	125, 132, 133, 142, 154, 157	Lambda Probes Sockets	191
Caliper	106	Extraction Tools	29, 196 - 200	Leak-Off Oil Pliers	216
Cam Belt Tension Gauge	206	Extractors	98	Leather Bags	223
Camshaft Adjustment Devices	204 - 206			LED Inspection Lamp	121
Car Body Chisel	176	F		Letter Steel Stamp Set	88
Car Body Tools	170 - 177	Feeler Gauges	23, 104	Lever Grease Gun	119
Carburettor Screwdrivers	76	Figure Steel Stamp Set	88	Lintel Adjusting Tool	188
Car Electricity Tools	196 - 200	Files	101	Locking Tools	204 - 207
Car Light Tester	75, 194	Five Star Wrench	203	Long Flat Nose Pliers	50, 60
Carpenters Pincers	53	Flaring Tools	103	Long Round Nose Pliers	50, 60
Center Punch	90, 91	Flare Nut Ring Spanners	10, 18, 44, 180		
Chain Pipe Cutter	102, 191	Flat Cold Chisels	89, 91	M	
Chassis Tools	188, 189	Flat Nose Pliers	186	Magnetic Parts Bowl	121
Chisels	13, 89, 91	Flowing and Binding Lubricant	203	Magnetic Pick Up Tools	116
Circlip Pliers	10, 18, 21, 56, 57	Four Way Rim Wrenches	184, 185	Magneto Spanners	37
Clamp Nut Wrenches	218			Marking Tool	106
Claw Wrenches	219	G		Measuring Tape	104
Club Hammer	87	Generator Assembly Sockets	201	Measuring Tools	23
Coil Spring Compressors	188	Glass Scraper	178	Metal Pipe Cutter	102
Combination Ratchet Spanners	39	Glow Plug Sockets	28, 138, 214	Mirrors	120
Combination Spanners	10, 12, 13, 18	Glow Plug Thread Repair Kit	215	Modules for Workshop Trolleys	10 - 13
	20, 22 - 24, 38, 40	Glow Plug Wrench	215		18 - 29
Contact Files	101	Grease Gun	119	Mounting Hook	190
Converters	28, 77, 78, 126	Grip Pliers	58, 59	Mounting Pliers	56
	134, 144, 154, 156				
Cooling System Tools	195				
Crank Locking Pin	205				
Crimping Pliers	53				
Cross Cut Chisels	89				

	Seite Page		Seite Page		Seite Page
N		Socket Rail	127, 129, 135, 136 145, 203	Water Pump Pliers	54, 55
Nozzle Adjusting Tool	179	Socket Sets	11 - 13, 19 - 22, 24, 25, 28 29, 131, 138, 139, 141, 146 - 152 155, 157, 159 - 162, 164, 167	Wedges	177, 190
Nut Splitters	99	Sockets	127, 129, 134, 136, 144 145, 147, 148, 154, 155, 157	Weight Pliers	186
O		Spark Plug Brush	213	Welding Spot Cutter	120, 176
Offset Screwdrivers	75	Spark Plug Pliers	213	Wheel Bearing Extractors	189
Oilers	118	Spark Plug Sockets	136, 148, 214	Wheel Cap Wrenches	218
Oilfilter Sockets	211	Spark Plug Wrenches	212	Wheel Hub Socket	189
Oilfilter Wrenches	210, 211	Speed Brace	133, 143	Wheel Nut Wrenches	184, 185
Oil Service Tools	209 - 211	Spinner Handle	126	Wheel Tools	185 - 187
Open Ended Slogging Spanners	46	Spirit Level	105	Windscreen Tools	178, 179
Open End Insert Tools	114	Spreader	189	Wire Stripping Pliers	54, 61
Oxygen Sockets	191	Spring Compressors	188	Workshop Squares	105
P		Spring Spanner for Exhaust Systems	190	Workshop Trolleys & Accessories	8 - 33
Parallel Pin Punches	90, 91, 182	Square	105		
Pen Light	121	Starter and Manifold Spanners	42		
Pick Up Tools	116	Steel Stamp Sets	88		
Pin Handles	44	Straight Edge Rule	105		
Pin Punches	90, 91, 182	Strap Wrenches	209		
Pipe Cutters	102, 191	Striking Face Ring Spanners	46		
Pipe Head Spanners	45	Suction Lifter	179		
Pipe Wrenches	57	Swivel Handle	112, 133, 143		
Piston Ring Compressors	208	T			
Piston Ring Pliers	208	Tap Wrenches	98		
Plastic Wedges	177	Telephone Pliers	50, 51, 55, 61		
Pliers	10, 12, 13, 18, 20 - 22 24, 25, 50 - 61, 208, 213, 216	Telescopic Mirror	120		
Pneumatic Spotle Drill	120	T-Handle	125, 126, 133, 143		
Power Shanks	77	Thread Gauges	104		
Precision crewdrivers	28, 73	Threading Bits	99		
Pry Bar	187	Thread Repair Tools	99, 100		
PTFE Lubrication Spray	203	Timing Tools	204 - 207		
Pullers	92 - 94, 97, 179, 207	TIN Bit Assortment	82		
Pulley Wrenches	201, 202	Tin Snips	175, 176		
Punch and Flange Tool	175	Tool Boxes	225		
Punches	90, 91	Torque Multiplier	111		
R		Torque Screwdrivers	115		
Ratchet	113, 124, 132, 140 141, 153, 156	Torque Tester	111		
Refractometer	195	Torque Wrenches	107 - 110, 112 - 115		
Release Tools	196 - 200	Tower Pincers	53		
Reversible Blade Screwdriver	71, 77	Trolley for Tools	224		
Ring Jaw Wrenches	10, 12, 13, 18, 20 22 - 24, 38, 40	Truck Tools	218 - 220		
Ring Ratchet Spanners	10, 18, 21	Tubular Box Spanners	45, 220		
Rubber Mallets	87	Turbocharger Wrench	203		
Rules	104, 105	Twist Sockets	28, 98, 159		
Rust Remover	183	Tyre Levers	186, 187		
S		Tyre Profile Depth Gauge	186		
Sanitary Wrench	37	U			
Scrapers	117, 118, 178	Universal Joint	113, 125, 133, 143, 154		
Screwdriver Sockets	11, 19, 21, 22 127 - 129, 135 - 137 145 - 149, 151, 152	V			
Screwdrivers	11 - 13, 19 - 25, 64 - 83	Valve Ring Pliers	208		
Screwdrivers, reversible blade	28, 71, 77	VDE-Tools	10, 11, 18, 19 60, 61, 72		
Screw Extractors	98	Vernier Caliper	106		
Scriber	106	Vices	119		
Separators	96	Visco-Coupling Wrench	202		
Side Cutting Nippers	51, 52, 55, 60, 61	Voltage Testers	72, 75		
Sliding T-Handle	125, 132, 142, 153 156	W			
		Warding Files	101		

Numerischer Index / Numerical Index

	Seite Page		Seite Page		Seite Page
100	36	470	210	662	73
103	36	500	50, 51	663	73
104	36	500 Mod	10, 11, 18, 19, 21	665 Mod	28, 73
105	36	500 VDE	60	670	70, 71
105 Mod	10, 18	501	51	671	71
107	36	501 Mod	10, 18	672	71
108	36	501 VDE	61	672 Mod	28, 71
112	36	506	153	680	74, 76
114	36	520	50	681 VDE	72
133	202	520 VDE	60	694	77
145	37	525	50	696	77
150	37	525 VDE	60	700	86
150 Mod	28	527	52	701	86
153	201	530	52	702	86
155	201	532	51	705	86
158	37	532 VDE	60	705 Mod	11, 12, 19 - 25
159	37	535	52	706	86, 87
175	46	537	216	707	87
185	38	538	216	710	87
185 Mod	10, 18	540	56	712	88
186	39	544	53	713	88
186 Mod	10, 18, 21	545	53	714	89, 91
188	42	546	171	715	89, 91
190	40	548	192, 193	716	90, 91
190 Mod	10 - 12, 18 - 20, 22 - 24	549	171	717	90, 91
195 Mod	23, 25	554	54	718	90, 91, 182
200	41	556	54, 55	719	91
204	41	556 Mod	10, 12, 18, 20, 22 - 25	724	92
205	41	557	55	725	93
205 Mod	10, 11, 18, 19, 21	558	56	726	92, 94
206	41	560	53	727	94
207	41	561	53	728	94
211	41	563	188	729	95
214	41	564	190	730	98
220	42	565	208	731	95 - 97, 179, 188, 201, 207
220 Mod	10, 18	567	208	732	173
221	42	568	213	734	173
224	43	569	213	735	174
224 Mod	10, 18	570	181, 182	736	174
226	43	570 Mod	29, 181	738	87
230	43	572	53	740	175
242	170	573	186	741	175
243	170	574	186	745	175
244	170	575	54	746	175
245	170	576	54	747	176
246	171	576 VDE	61	748	176
250	180	578	56, 57	752	186
251	44, 180	578 Mod	10, 11, 18, 19, 21	753	187
251 Mod	10, 18	580	56	754	187
253	216	582	56	757	187
254	202, 203	584	57	758	187
255	181	585	50, 186	759	187
262	209	585 VDE	61	760	104
265	209	586	51	764	104
266	209	586 VDE	61	771	98
270	46	587	58, 59, 171, 172, 193	772	98
280	47	588	58, 59	773	98
290	47	589	58, 59, 173	773 Mod	28, 159
300	44	590	39	774	99, 100
320	45	591	39	775	101
340	184	596	57	776	101
342	44, 184	597	57	778	101
350	184	600	68	779	101
352	184	600 Mod	23, 25	780	101
355	185	605	69	781	116, 213
356	185	606	156	782	116
357	185	615	69, 74	783	195
358	185	615 Mod	11, 12, 19 - 25	784	116
366	212	616 Mod	11, 19	785	116
367	212	616 VDE	72	786	117
372	212	620	74, 178	787	117
373	212	620 Mod	11, 19, 21	788	117
380	45	627	75	789	117
383	212	628	75	790	118
418	208	630	75, 178	793	118
419	208	632	75, 194	794	119
425	209	633	75, 194	798	104 - 106
426	209	635	72	798 Mod	23
428	210	636	72	799	106
429	211	640	76	800	198 - 200
430	44	650	69	800 Mod	29, 196, 197
440	64	655	70, 74, 76	805	195
440 L	65, 66	656 VDE	72	806	195
441	68	657	70	808	102, 191
442	67	658	70	810	102
443	67, 68	660	73	813	102
444 L	66, 67	661	73	814	102

	Seite Page
815	119
818	119
820	99
822	99
825	103
826	103
829	52
829 VDE	60
835	103
840	118, 178
841	178
842	177
843	177
846	176
849	193
852	183
854	183
858	178, 179
859	179
860	120, 176
862	120, 176
863	179
864	179
865	179
872	177
876	120
877	116
878	121
880	121
880 Mod	189
881	121
910	204
911	204
912	204 - 206
913	206
914	206
915	206
916	207
920	207
938	220
969	81
2061	124
2062	124
2063	124
2064	125
2065	125
2066	125
2067	125
2068	125
2069	125
2073	126
2074	126
2075	127
2076	127
2077	127, 128
2078	128
2080	129
2082	126
2082 Mod	28, 126
2083	126
2084	77, 126
2085	77
2090	128
2092	128
2093	128
2094	129, 203
2115	130
2135	130
2135 Mod	11, 19, 21 - 25
2136	130
2136 Mod	11, 12, 19, 20, 28, 131
2150	131
3061	132
3064	132
3065	132
3066	132
3067	133
3068	133
3070	133
3072	133
3074	133
3075	134, 135
3076	135
3077	135
3078	135
3079	136
3080	136

	Seite Page
3081	136, 191, 214
3082	134
3083	134
3085	77
3086	77, 134
3090	137
3092	137
3093	137
3096	138, 214, 215
3096 Mod	28, 138, 214
3115	138
3115 Mod	11, 19, 21, 29, 139
3125 Mod	29, 139
4060	140
4061	140, 141
4061 Mod	29, 141
4062	140
4064	142
4065	142
4066	142
4067	143
4068	143
4070	143
4072	143
4075	144, 145
4076	145
4077	145
4078	146, 189
4078 Mod	11, 19, 21 - 23
4079	146, 147, 150, 201, 205
4080	147
4081	147, 148, 191
4081 Mod	214, 216, 217
4082	22, 23, 25
4082 Mod	144
4083	144
4084	77, 144
4085	77
4086	211
4087	161
4089	218
4090	148
4090 Mod	28, 148
4092	148, 149
4092 Mod	11, 19, 21, 28, 149
4094	218
4105	150
4105 Mod	11, 12, 19 - 25
4110	150
4111	150
4114	151
4114 Mod	29, 152
4115	151
4135	151
4140 Mod	29, 152
4141 Mod	152
5060	153
5062	153
5064	153
5065	154
5066	154
5068	154
5075	154, 155
5079	189
5080	218
5081	218
5084	219
5142	155
5143	155
6060	156
6064	156
6065	157
6066	157
6075	157
6082	154, 156
6083	154, 156
6144	157
6174	107, 108
6175	107
6176	108, 109
6177	109
6178	110
6180	111
6181	111
6182	111
6184	112
6185	112 - 115

	Seite Page
6186	113 - 115
6187	113
6190	114
6191	114, 115
6195	115
6200	156
7010	158
7011	158
7012	158
7015	159
7020	78
7022	78
7023	78
7024	79
7025	79
7026	80
7028	80
7029	80
7030	78
7032	78
7033	78
7034	79
7035	79, 80
7036	80
7038	80
7040	78
7047	81
7049	81
7050	81
7051	82
7052	83
7052 Mod	28, 29, 83, 139
7053	217, 220
7055	160, 161
7055 Mod	22, 23
7056	159, 161
7057	159
7058	160
7059	161
7060	162
7061	162
7062	162
7065	163
7065 Mod	22, 23
7066	164
7067	163
7068	163
7069	163
7070	166
7071	166
7072	165
7073	166
7074	166
7080	164
7081	165
7082	165
7083	165
7090	167
7099	167
8005	184
8140	30, 31
8140 Mod	19
8141	31, 32
8142	31
8146	183, 203
8153	222 - 224
8155	16, 21
8155 Mod	19
8156	15, 20, 24, 25, 27
8156 Mod	19
8157	14, 20
8158	9, 12, 27
8158 Mod	11
8159	8, 12
8160	223
8161	17, 27
8162	9, 11, 13, 27
8162 Mod	13
8170	225
8171	225
8175	225
8176	225

